

13. Objects

This chapter explains how to use different objects.

13.1. Bit Lamp	13-3
13.2. Word Lamp	13-5
13.3. Set Bit.....	13-10
13.4. Set Word	13-13
13.5. Function Key	13-23
13.6. Toggle Switch	13-29
13.7. Multi-State Switch	13-32
13.8. Slider	13-36
13.9. Numeric	13-43
13.10. ASCII.....	13-62
13.11. Indirect Window	13-67
13.12. Direct Window	13-75
13.13. Moving / Rotating Shape	13-81
13.14. Animation	13-87
13.15. Bar Graph.....	13-91
13.16. Meter Display.....	13-99
13.17. Trend Display	13-107
13.18. History Data Display.....	13-130
13.19. Data Block Display	13-139
13.20. XY Plot.....	13-148
13.21. Alarm Bar and Alarm Display.....	13-155
13.22. Event Display.....	13-164
13.23. Data Transfer.....	13-178
13.24. Backup	13-186
13.25. Media Player	13-194
13.26. BACnet Schedule.....	13-200
13.27. PLC Control	13-204
13.28. Scheduler	13-211
13.29. Option List.....	13-221
13.30. Timer.....	13-229
13.31. Video In.....	13-234
13.32. System Message	13-241

13.33. Recipe View	13-243
13.34. Flow Block.....	13-250
13.35. Operation Log	13-255
13.36. Combo Button.....	13-269
13.37. Circular Trend Display	13-278
13.38. Picture View.....	13-288
13.39. File Browser	13-291
13.40. Import/Export.....	13-295
13.41. Pie Chart	13-300
13.42. Barcode.....	13-304
13.43. String Table	13-316
13.44. Database	13-318
13.45. Dynamic Scale.....	13-335
13.46. Dynamic Drawing.....	13-338
13.47. PDF Reader	13-344
13.48. Table.....	13-346
13.49. VNC Viewer	13-348
13.50. Contacts Editor	13-352
13.51. Event Bar Chart.....	13-355
13.52. Action Trigger.....	13-361
13.53. Calendar.....	13-368
13.54. Touch Gesture.....	13-370
13.55. PLC Web Browser.....	13-372
13.56. Condition	13-376
13.57. FTP Connection.....	13-380
13.58. Date/Time	13-383
13.59. Template	13-385

13.1. Bit Lamp

13.1.1. Overview

Bit Lamp object displays the state of a designated bit address. If the bit state is OFF, the State 0 shape will be displayed. If the bit state is ON, the State 1 shape will be displayed.



13.1.2. Configuration



Click [Object] » [Bit Lamp] icon on the toolbar to open a Bit Lamp object property dialog box. Set up the properties, press OK button, and a new Bit Lamp object will be created.

General Tab

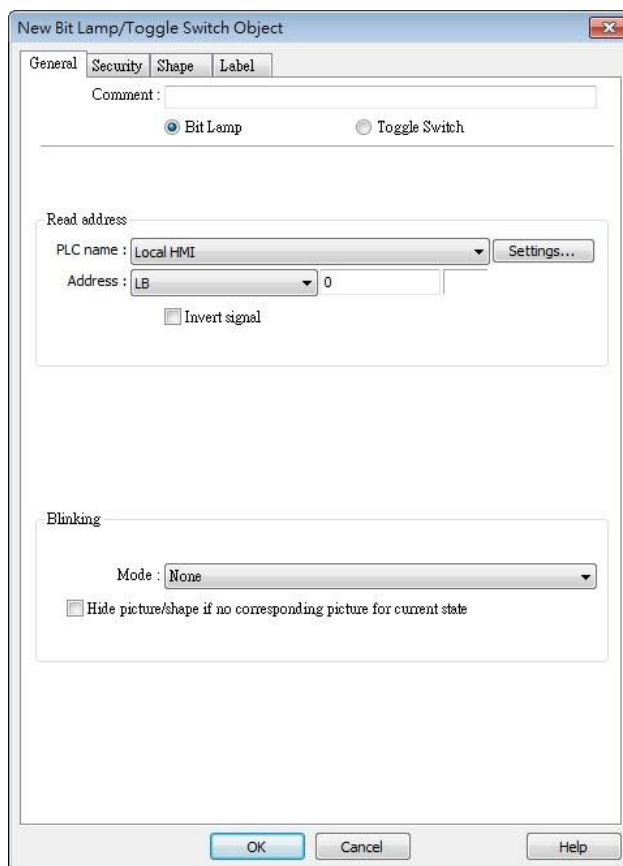

The dialog box is titled "New Bit Lamp/ Toggle Switch Object" and has four tabs: General, Security, Shape, and Label. The General tab is active. It contains the following fields and controls:

- Comment: A text input field.
- Radio buttons: Bit Lamp and Toggle Switch.
- Read address section:
 - PLC name: A dropdown menu showing "Local HMI" and a "Settings..." button.
 - Address: A dropdown menu showing "LB" and a text input field containing "0".
 - Invert signal.
- Blinking section:
 - Mode: A dropdown menu showing "None".
 - Hide picture/shape if no corresponding picture for current state.

At the bottom of the dialog are three buttons: OK, Cancel, and Help.

Setting	Description
Comment	User can describe the information of the object. Bit Lamp / Toggle Switch Switch between Bit Lamp and Toggle Switch features.
Read address	Click [Setting] to select the [PLC name], [Address], [Device type], [System tag], [Index register] of the bit device that controls the [Bit Lamp] object. Users can also set address in [General] tab while adding a new object. Invert signal Reverses the display of ON / OFF states. For example, if [Invert signal] check box is selected, when the designated bit is OFF, the object displays ON state.
Blinking	The appearance of the object may alternate between states when the bit is ON or OFF. Mode: None No blinking. Alternating image on state 0 The appearance of the object alternates between State 0 and 1 when the bit is OFF. Alternating image on state 1 The appearance of the object alternates between State 0 and 1 when the bit is ON. Blinking on state 0 The State 0 appearance of the object will blink when the bit is OFF. Blinking on state 1 The State 1 appearance of the object will blink when the bit is ON. Hide picture/shape if no corresponding picture for current state If selected, when there are not enough pictures to represent all the states, hides the picture. Otherwise, displays the last state.

Note

- In [Label] tab, if select [ON=OFF (use state 0)] check box, both state 0 and 1 follow the settings of state 0.

13.2. Word Lamp

13.2.1. Overview

Word Lamp object displays the state according to the value of a designated word register. Up to 256 states are available. When the value of the register is 0, State 0 appearance of the object is displayed, and with the register value being 1 the object displays State 1, and so on.

Numeric Display (LW0) Word Lamp (LW0)

0

State 0

Numeric Display (LW0) Word Lamp (LW0)

1

State 1

Numeric Display (LW0) Word Lamp (LW0)

2

State 2

13.2.2. Configuration



Click [Object] » [Word Lamp] icon on the toolbar to open a Word Lamp object property dialog box. Set up the properties, press OK button, and a new Word Lamp object will be created.

General Tab

Setting	Description
Comment	User can describe the information of the object. Word Lamp / Multi-State Switch Switch between Word Lamp and Multi-State Switch features.
Mode / Offset	Word Lamp object offers the following three modes: Value The state is displayed according to the value in the designated word address and plus the [Offset]. As shown below, if the value within LW-200 is 3, since the offset is set to 3, the shape of state 0 is displayed. (value 3 - offset 3)

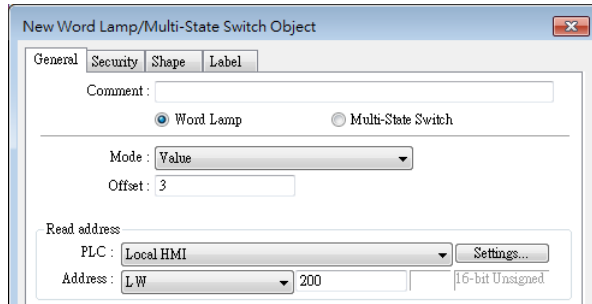

LSB

Convert the value from decimal to binary. The least significant active bit in a binary data word selects the state displayed.

Decimal	Binary	Displayed state
0	0000000000000000	State = 0 when all bits are 0.
1	0000000000000001	The lowest non-zero bit is bit 0, state = 1.
2	0000000000000010	The lowest non-zero bit is bit 1, state = 2.
3	0000000000000011	The lowest non-zero bit is bit 0, state = 1.
4	0000000000000100	The lowest non-zero bit is bit 2, state = 3.
7	0000000000000111	The lowest non-zero bit is bit 0, state = 1.
8	0000000000001000	The lowest non-zero bit is bit 3, state = 4.
16	0000000000010000	The lowest non-zero bit is bit 4, state = 5.
32	0000000000100000	The lowest non-zero bit is bit 5, state = 6.
64	0000000001000000	The lowest non-zero bit is bit 6, state = 7.
128	0000000010000000	The lowest non-zero bit is bit 7, state = 8.
256	0000000100000000	The lowest non-zero bit is bit 8, state = 9.
512	0000001000000000	The lowest non-zero bit is bit 9, state = 10.
1024	0000010000000000	The lowest non-zero bit is bit 10, state = 11.
2048	0000100000000000	The lowest non-zero bit is bit 11, state = 12.
4096	0001000000000000	The lowest non-zero bit is bit 12, state = 13.
8192	0010000000000000	The lowest non-zero bit is bit 13, state = 14.
16384	0100000000000000	The lowest non-zero bit is bit 14, state = 15.
32768	1000000000000000	The lowest non-zero bit is bit 15, state = 16.

Bit combination

Lamp state depends on the states of bit combinations, where PLC 1

represents the least significant bit (LSB), PLC 2 represents the next LSB, and so on. Maximum number of bit is 4, for a total of 16 states. Changing [No. of states] in Attribute group box changes the number of read addresses.

Word Lamp Multi-State Switch

Mode:

Read address

PLC 1:

Address 1:

PLC 2:

Address 2:

PLC 3:

Address 3:

PLC 4:

Address 4:

Attribute

No. of states:

Change state by time

The state displayed changes on a time basis. The frequency can be set.

Read address

Click [Setting] to select the [PLC name], [Address], [Device type], [System tag], [Index register] of the word device that controls the [Word Lamp] object. Users can also set address in [General] tab while adding a new object.

Attribute

No. of states

The number of states is utilized by the object. The state is numbered from 0, so the number of states minus 1 will be the state number. If the value within the word register is \geq [No. of states] defined in Attribute, the highest state will be displayed.

If the number of states is set to 8, the valid states will be 0, 1, 2, ..., 7. In this case if the word value is 8 or higher, the system will display the state 7 shape.

Hide picture/shape if no corresponding picture for current state

If selected, when there are not enough pictures to represent all the states, hides the picture. Otherwise, displays the last state.

Note

- In [Label] tab, Language 1 determines the relevant settings of the font. For Language 2~8, only the font size can be changed and other settings follow Language 1.

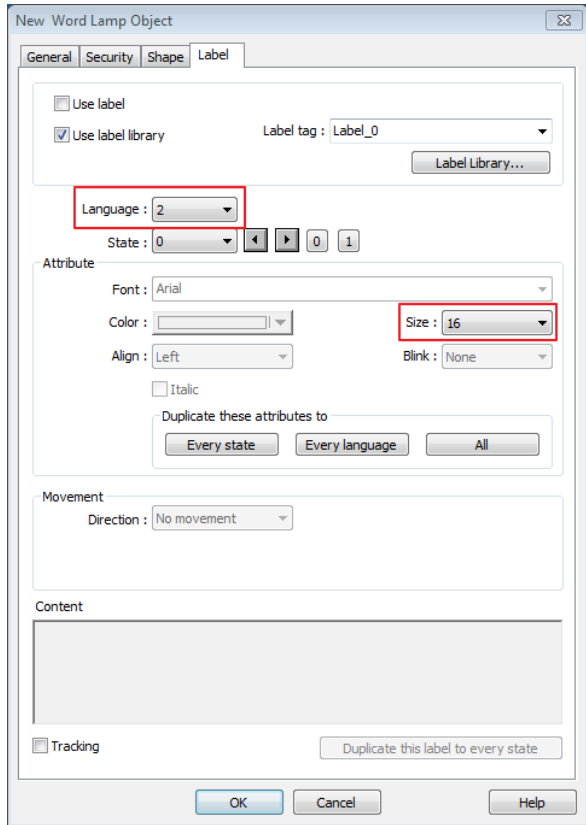
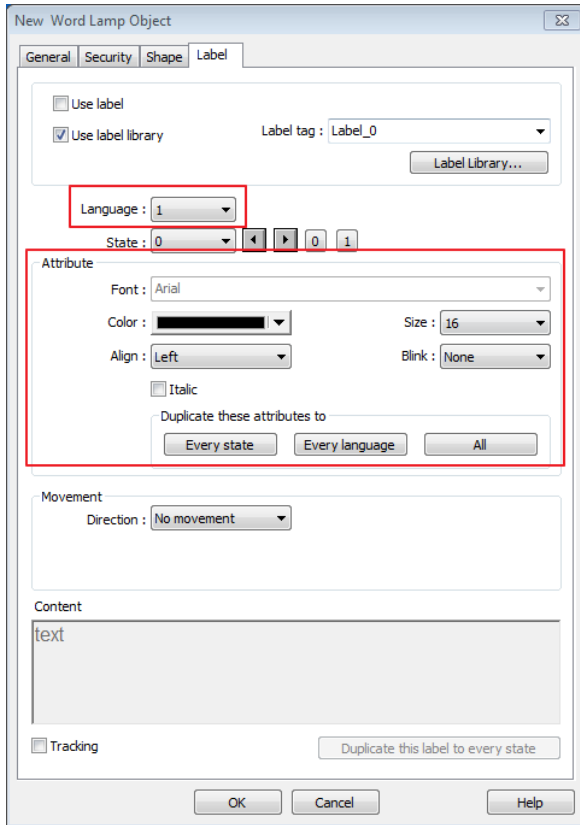

13.3. Set Bit

13.3.1. Overview

The Set Bit object provides two operation modes: manual or automatic. Manual mode can trigger a designated bit address to change the state between ON and OFF when the object is touched. In automatic mode, the bit is automatically activated when a pre-defined condition occurs; touching the button will not be effective.

13.3.2. Configuration



Click [Object] » [Set Bit] icon on the toolbar to open a Set Bit object property dialog box. Set up the properties, press OK button, and a new Set Bit object will be created.

General Tab

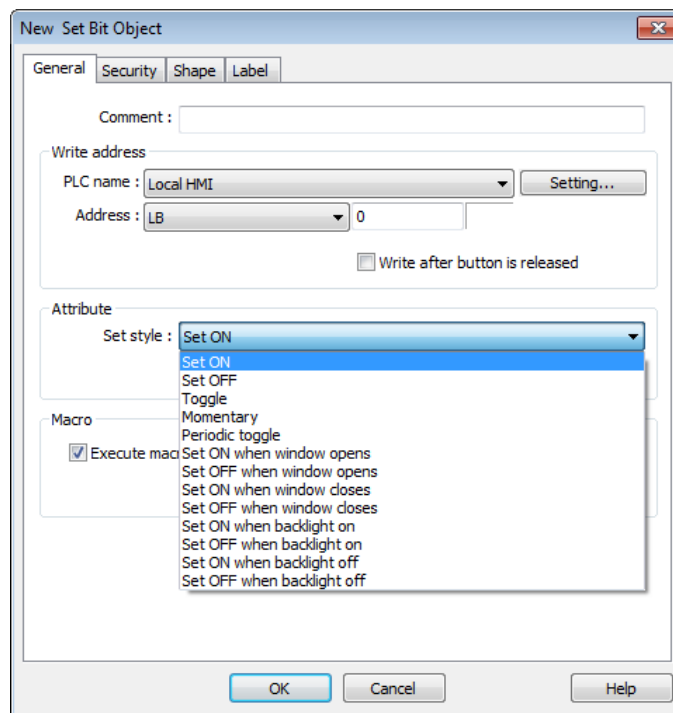

Setting	Description
Write address	Click [Setting] to select the [PLC name], [Address], [Device type], [System tag], [Index register] of the bit device that controls the Set Bit object. Users can also set address in [General] tab while adding a new object.
Write after button is released	

If this function is selected, the action is delayed till button is released; otherwise, the action is executed once the button is pressed. This function does not work with momentary buttons.

Mode / Offset	Set style	Description
	Set ON	Set ON the designated bit of the device.
	Set OFF	Set OFF the designated bit of the device.
	Toggle	Alternates the bit state each time pressed.
	Momentary	Holds the bit ON only while button is pressed.
	Periodical toggle	Set a designated bit ON and OFF at a set time interval. Time interval can be selected; the range is from 0.1 to 25.5 seconds.
	Set ON when window opens	Set ON the bit within the window when the window opens.
	Set OFF when window opens	Set OFF the bit within the window when the window opens.
	Set ON when window closes	Set ON the bit within the window when the window closes.
	Set OFF when window closes	Set OFF the bit within the window when the window closes.
	Set ON when backlight on (N/A for cMT-SVR)	Set the bit ON when the backlight is turned ON.
	Set OFF when backlight on (N/A for cMT-SVR)	Set the bit OFF when the backlight is turned ON.
	Set ON when backlight off (N/A for cMT-SVR)	Set the bit ON when the backlight is turned OFF.
	Set OFF when backlight off (N/A for cMT-SVR)	Set the bit OFF when the backlight is turned OFF.

Macro

Set Bit object can trigger the start of a Macro routine when the Macro has been created in advance.



For more information, see “18 Macro References”.

Trigger mode

If [Set style] is set to [Toggle], there is a further selection to make of whether the macro operates after Off to ON, ON to OFF transition, or at both of the changes of state.

**Note**

- In [Label] tab, if select [ON=OFF (use state 0)] check box, both state 0 and 1 follow the settings of state 0.

- Using address types other than PLB or PLW_Bit for Set Bit objects with [Periodic Toggle] attribute is not supported by cMT-SVR.
- The Set Style setting in the General tab determines which settings are available in the Security tab. When the Set Style is [Set ON / OFF when window opens], there will be no settings available in the Security tab.
- When [Execute macro] is selected, the sequence in which the object's write operation and the macro execution is determined by the HMI runtime. In order to exactly arrange the write operation and the macro execution in the desired way, specify the sequence by configuring a Combo Button instead.

13.4. Set Word

13.4.1. Overview

The Set Word object provides two operation modes: manual or automatic. Manual mode can change the value in a designated word address when the object is touched. In automatic mode, the word register is automatically activated when a pre-defined condition occurs; touching the button will not be effective.

13.4.2. Configuration



Click [Object] » [Set Word] icon on the toolbar to open a Set Word object property dialog box. Set up the properties, press OK button, and a new Set Word object will be created.

General Tab

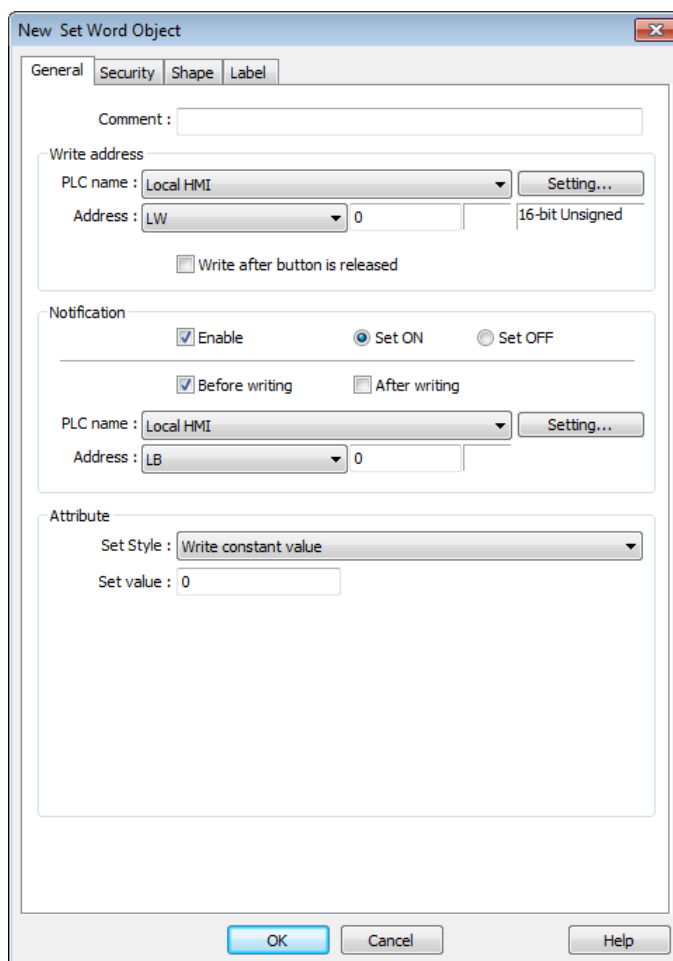

The screenshot shows the 'New Set Word Object' dialog box with the 'General' tab selected. The dialog has four sub-sections: 'Write address', 'Notification', and 'Attribute'. The 'Write address' section includes a 'Comment' field, a 'PLC name' dropdown set to 'Local HMI', an 'Address' dropdown set to 'LW' with a value of '0', and a '16-bit Unsigned' checkbox. The 'Notification' section has 'Enable' checked, 'Set ON' selected, and 'Before writing' checked. The 'Attribute' section has 'Set Style' set to 'Write constant value' and 'Set value' set to '0'. Buttons for 'OK', 'Cancel', and 'Help' are at the bottom.

Section	Property	Value
Write address	Comment	
	PLC name	Local HMI
	Address	LW 0
	16-bit Unsigned	<input type="checkbox"/>
Notification	Enable	<input checked="" type="checkbox"/>
	Set ON	<input checked="" type="radio"/>
	Set OFF	<input type="radio"/>
	Before writing	<input checked="" type="checkbox"/>
Attribute	PLC name	Local HMI
	Address	LB 0
	Set Style	Write constant value
	Set value	0

Setting	Description
Write address	Click [Setting] to select the [PLC name], [Address], [Device type], [System tag], [Index register] of the word device that controls the Set Word object. Users can also set address in [General] tab while adding a new object. Write after button is released If this function is selected, the action is delayed till button is released; otherwise, the action is executed once the button is pressed.
Notification	If this check box is selected, it will notify a designated bit address (setting ON or OFF). Before writing / After writing Set the state of the designated bit address before or after the manual operation.
Attribute	Set Style Select the button action from the drop down list, see Example 2. Dynamic limits Set the [Bottom limit] and [Upper limit] by a designated register, see Example 1.

Example 1

Set the [Bottom limit] and [Upper limit] by a designated register. When Dynamic Address is LW-n, where n is an arbitrary number, the rule of setting Upper / Bottom limit is:

Content	16-bit	32-bit	64-bit (cMT / cMT X only)
Dynamic address	LW-n	LW-n	LW-n
Bottom limit	LW-n	LW-n	LW-n
Upper limit	LW-n+1	LW-n+2	LW-n+4

When Dynamic Address is LW-100, the rule of setting Upper / Bottom limit is:

Content	16-bit	32-bit	64-bit (cMT / cMT X only)
Dynamic address	LW-100	LW-100	LW-100
Bottom limit	LW-100	LW-100	LW-100
Upper limit	LW-101	LW-102	LW-104

Example 2

The available button actions are:

- Write constant value

Write a preset value. Each time the button is pressed, the value in [Set value] is written to the designated register. Data format is as set by the [Write address] above; it can be 16-bit BCD, 32-bit BCD, ...64-bit Double. In the following figure, when the button is pressed, the number 12 is written to the designated register.

Attribute

Set Style : Write constant value

Set value : 12

- Write constant string (cMT / cMT X only)

Write a preset string. Each time the button is pressed, the string in [Set string] is written to the designated register. The string format can be: UTF-8, Unicode, Latin-1...etc. In the following figure, when the button is pressed, the string "abcd" is written to the designated register.

Attribute

Set Style : Write constant string

Set string : abcd

String format : UTF-8 (Default)

- Increment value (JOG+)

Increase value in register by a set amount in [Inc. value], each time when the button is pressed, up to the [Upper limit]. As shown below, each button press increases the value in the register by 1 until the value is 10.

Attribute

Set Style : Increment value (JOG+)

Inc. value : 1 Upper limit : 10

- Decrement Value (JOG-)

Decrease value in register by a set amount in [Dec. value], each time when the button is pressed, down to the [Bottom limit]. As shown below, each button press decreases the value in the register by 1 until the value is 0.

Attribute

Set Style : Decrement value (JOG-)

Dec. value : 1 Bottom limit : 0

- Bounce (up->down->up) (cMT / cMT X only)

Each time when the button is pressed, the value in the register is increased by the [Inc. value] until the [High limit] is reached, and then the value is decreased by the [Inc. value], each time when the button is pressed, down to the [Low limit]. As shown below, the system will increase the value in the register by 1 each time when the button is pressed, until the value is 10, and then decrease the value by 1 each time when the button is pressed, until the value is 0, and then increase the value again.

Attribute

Set style :

Low limit : High limit :

Inc. value :

- Press and hold increment (JOG++)

When the button is held longer than a set time in [JOG delay], it will increase the value in a register by a set amount :[Inc. value] at a set rate :[JOG speed], to the [Upper limit].

As shown below, when the button is pressed, it increases the value in the designated register by 1. When the button is held longer than 1 second, it increases the value in register by 1 every 0.5 second, till the value is 10.

Attribute

Set Style :

Inc. value : Upper limit :

JOG delay : JOG speed :

- Press and hold decrement (JOG--)

When the button is held longer than a set time in [JOG delay], it will decrease the value in a register by a set amount: [Dec. value] at a set rate: [JOG speed], to the [Bottom limit].

As shown below, when the button is pressed, it decreases the value in the designated register by 1. When the button is held longer than 1 second, it decreases the value in register by 1 every 0.5 second, till the value is 0.

Attribute

Set Style :

Dec. value : Bottom limit :

JOG delay : JOG speed :

- Periodic JOG++

This automatic function increases the value in the register by a set amount: [Inc. value], at a set rate: [Time interval], to the [Upper limit]. As shown below, the system will automatically increase the value in the register by 1 every 0.5 second, till the value is 10. Then the value returns to 0 and add 1 every 0.5 second again.

Attribute

Set Style : Periodic JOG++ (up->0->up->...)

Inc. value : 1 Upper limit : 10

Time interval : 0.5 second(s)

- Automatic JOG++

This automatic function increases the value in the register by a set amount: [Inc. value], at a set rate: [Time interval], to the [Upper limit].then holds this value. As shown below, the system will automatically increase the value in the register by 1 every 0.5 second, till the value is 10, and then stop.

Attribute

Set Style : Automatic JOG++ (up to high limit)

Inc. value : 1 Upper limit : 10

Time interval : 0.5 second(s)

- Automatic JOG--

This automatic function decreases the value in the register by a set amount: [Dec. value], at a set rate: [Time interval], to the [Bottom limit].then holds this value. As shown below, the system will automatically increase the value in the register by 1 every 0.5 second, till the value is 10, and then stop.

Attribute

Set Style : Automatic JOG-- (down to low limit)

Dec. value : 1 Bottom limit : 10

Time interval : 0.5 second(s)

- Periodic bounce

Increases the word address value to the [Upper limit] by a [Inc. value] at a set rate in [Time interval], then decreases to the [Bottom limit] by the same value at the same rate. As shown below, the system will increase the value in the designated register by 1 every 0.5 second, till the value is 10, and then decrease the value by 1 every 0.5 second till the value is 0 whenever the screen is active.

Attribute

Set Style : **Periodic bounce (up->down->up->...)**

Bottom limit : Upper limit :

Inc. value :

Time interval : **0.5 second(s)**

- Periodic step up

Step up to the [High limit] by [Inc. value] at a set rate in [Time interval], then reset immediately to the [Low limit]. The action repeats whenever the screen is active. As shown below, the system will increase the value in the designated register by 1 every 0.5 second, till the value is 10, and then reset to 0 and increase again, and the action repeats.

Attribute

Set Style : **Periodic step up (low to high...)**

Low limit : High limit :

Inc. value :

Time interval : **0.5 second(s)**

- Periodic step down

Step down to the [Low limit] by [Dec. value] at a set rate in [Time interval], then reset immediately to the [High limit]. The action repeats whenever the screen is active. As shown below, the system will decrease the value in the designated register by 1 every 0.5 second, till the value is 0, and then reset to 10 and decrease again, and the action repeats.

Attribute

Set Style : **Periodic step down (high to low...)**

Low limit : High limit :

Dec. value :

Time interval : **0.5 second(s)**

- Set when window opens / Set when window closes

Automatic function occurs whenever the screen is active. The value entered in [Set value] is set into the word address when the action occurs. If [Set value] is set to 5, when the window opens / closes, the system enters 5 into the designated register.

- Set when backlight on / Set when backlight off (Not supported on cMT-SVR)

Automatic function occurs whenever the backlight is active. The value entered in [Set value] is set into the word address when the action occurs. If [Set value] is set to 5, when the backlight turns ON / OFF, the system sets 5 into the designated register.

- Cyclic JOG+

Each time when the button is pressed, increases the word address value to the [Upper limit] by

[Inc. value] then reset to the [Bottom limit]. As shown below, each time when pressing the button, the system will increase the value in the designated register by 1, till the value is 10, and then reset to 0 and increase again by pressing the button.

The screenshot shows the 'Attribute' configuration window for 'Cyclic JOG+'. It includes a dropdown menu for 'Set Style' set to 'Cyclic JOG+', a 'Bottom limit' input field set to 0, an 'Upper limit' input field set to 10, and an 'Inc. value' input field set to 1.

- Cyclic JOG-

Each time when the button is pressed, decrease the word address value to the [Bottom limit] by [Dec. value] then reset to the [Upper limit]. As shown below, each time when pressing the button, the system will decrease the value in the designated register by 1, till the value is 0, and then reset to 10 and decrease again by pressing the button.

The screenshot shows the 'Attribute' configuration window for 'Cyclic JOG-'. It includes a dropdown menu for 'Set Style' set to 'Cyclic JOG-', a 'Bottom limit' input field set to 0, an 'Upper limit' input field set to 10, and a 'Dec. value' input field set to 1.

- Cyclic JOG++

When the button is held longer than a set time in [JOG delay], it increases the value in a register by a set amount in [Inc. value] at a set rate in [JOG speed], to the [Upper limit], then reset to the [Bottom limit]. As shown below, when the button is held longer than 0.5 second, increase the value in the designated register by 1 every 0.1 second, till the value is 10, and then reset to 0 and increase again by holding the button.

The screenshot shows the 'Attribute' configuration window for 'Cyclic JOG++'. It includes a dropdown menu for 'Set Style' set to 'Cyclic JOG++', a 'Bottom limit' input field set to 0, an 'Upper limit' input field set to 10, an 'Inc. value' input field set to 1, a 'JOG delay' dropdown menu set to '0.5 second(s)', and a 'JOG speed' dropdown menu set to '0.1 second(s)'.

- Cyclic JOG--

When the button is held longer than a set time in [JOG delay], decrease the value in a register by a set amount in [Dec. value] at a set rate in [JOG speed], to the [Bottom limit], then reset to the [Upper limit]. As shown below, when the button is held longer than 0.5 second, decrease the value in the designated register by 1 every 0.1 second, till the value is 0, and then reset to 10 and decrease again by holding the button.

Attribute

Set Style :

Bottom limit : Upper limit :

Dec. value :

JOG delay : JOG speed :

- Object Control Command (cMT / cMT X only)

Listed for selection are commands (with their corresponding command values) available for the control address of various functions. For a given function, with write address set to its control address, Set Word writes the command value and achieves function control.

Attribute

Set Style :

Object Type :

Command :

- System Tag Command (cMT / cMT X only)

When a system tag is set as write address, for example, LW-9134: Language Mode, the commands relating to the system tag can be selected.

Attribute

Set Style :

Language :

Security Tab

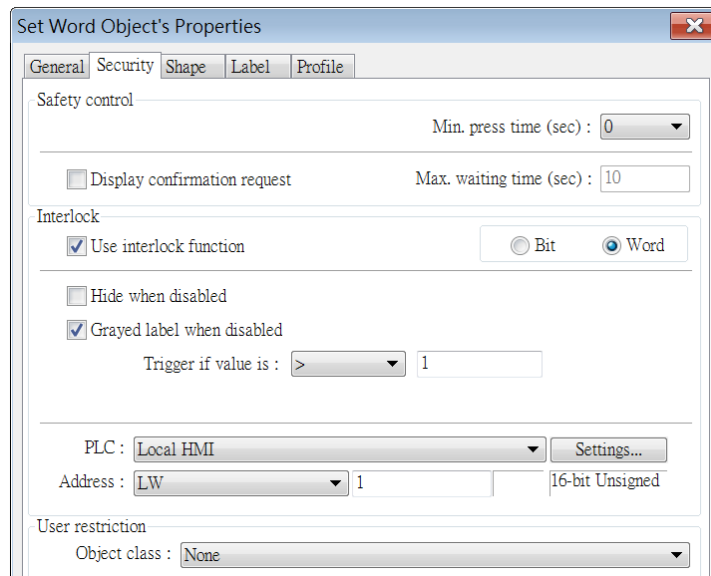

Setting	Description
Interlock	<p>Use interlock function</p> <p>When this option is enabled and [Word] is selected, whether the object is operable depends on the condition of a word address specified in [Trigger if value is:]. In the settings above, the object is operable only when the value in LW-1 is greater than 1.</p> <p>Hide when disabled</p> <p>The object is hidden when the specified condition does not occur in the specified word address.</p> <p>Grayed label when disabled</p> <p>The label of the object turns gray when the specified condition does not occur in the specified word address.</p> <div style="border: 1px solid gray; padding: 2px; display: inline-block; margin: 5px 0;">button</div> <p>Trigger if value is:</p> <p>This setting is for specifying a trigger condition. The available options are: >, <, ==, <>, >=, and <=. A tolerance value can be set for conditions == and <>.</p> <p>For example:</p> <div style="margin-left: 20px;"> <input checked="" type="checkbox"/> Hide when disabled <input type="checkbox"/> Grayed label when disabled Trigger if value is : == <input type="text" value="10"/> Tolerance : <input type="text" value="1"/> </div> <p>When the value is the specified word address is greater than or equal to 11, or smaller than or equal to 9, the object will be hidden and is not operable.</p>

Note

- Using address types other than PLW for Set Word objects with automatic attributes such as [Periodic set up], [Periodic set down], [Automatic JOG++], [Automatic JOG--], and [Periodic JOG++]...etc, is not supported by cMT-SVR.

13.5. Function Key

13.5.1. Overview

The Function Key object can be used for several tasks, such as switching between windows, keypad design, Macro execution, screen hardcopy, and setting USB security key.

Function Keys with [Screen hardcopy] or [Import user data/Use [USB Security Key]] selected do not work remotely on cMT Viewer.

13.5.2. Configuration



Click [Object] » [Function Key] icon on the toolbar to open a Function Key object property dialog box. Set up the properties, press OK button, and a new Function Key object will be created.

General Tab

cMT / cMT X Series

eMT, iE, XE, mTV Series

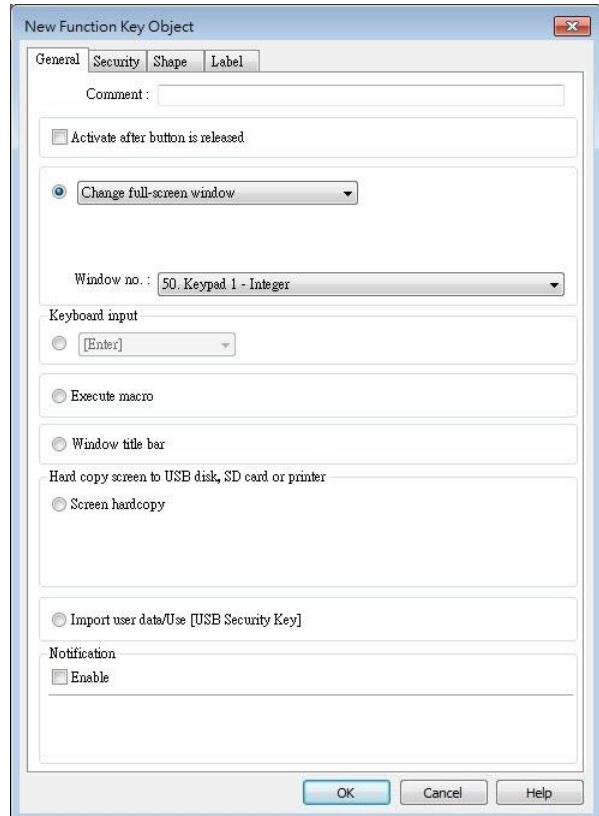
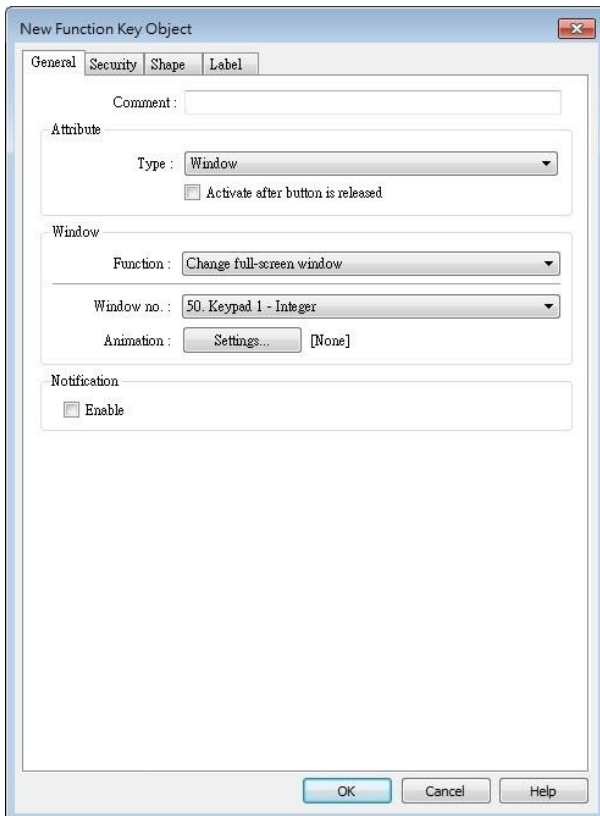

Setting	Description
Activate after button is released	If this function is selected, the action is delayed till button is released; otherwise, the action is executed once the button is pressed.
Change window	<p>Change full-screen window: Change to another base window.</p> <p>Change common window: Change common window.</p> <p>Display popup window: A pop-up window displays in the base window. If [Close this popup window when parent window is closed] check box is selected, the pop up window will be closed when change the base window to another window. Otherwise, a function key in the pop up window is needed to close it.</p>

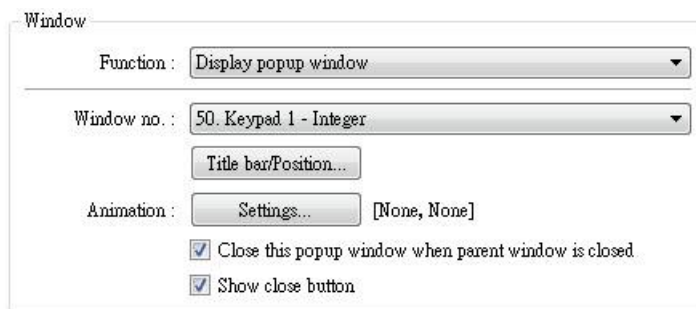



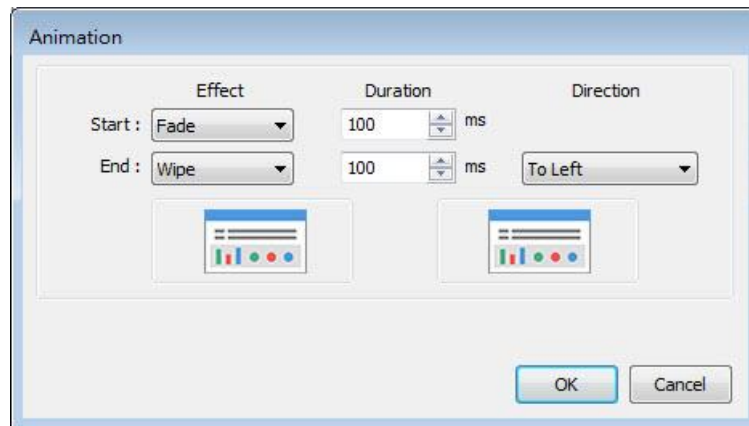

(cMT / cMT X Series) Animation Setting: cMT / cMT X Series allows using transition effects for opening popup windows using Function Keys. The settings can be opened by clicking [Animation Setting].

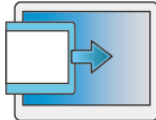
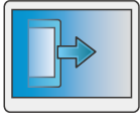
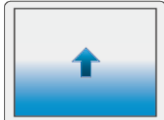
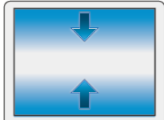

The effects are shown below. Different effects may be used for Start (window appears) and End (window disappears).

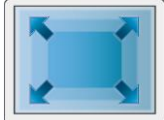
Effect Name	Transition
Fade	

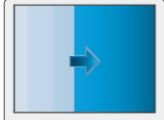
Fly	
Float	
Wipe	
Split	
Circle	
Clock	
Zoom	
Turn	
Push	

[Duration] specifies how many milliseconds (ms) a transition effect takes to complete.

[Direction] The direction of the transition.

Return to previous window: If this is selected, the Function Key will change from the current screen to the previous one displayed. For example, when window no. 10 is changed to window no. 20, press the function key to return to window no. 10. This function is only available for base window.

Close window: Close any active pop-up windows, message windows

included.

Display calculator window(cMT / cMT X Series): If this option is selected, clicking this Function Key can open a calculator with an unchangeable appearance. This calculator allows operators to do simple calculation and enter the result to a destination object by pressing the Enter key.

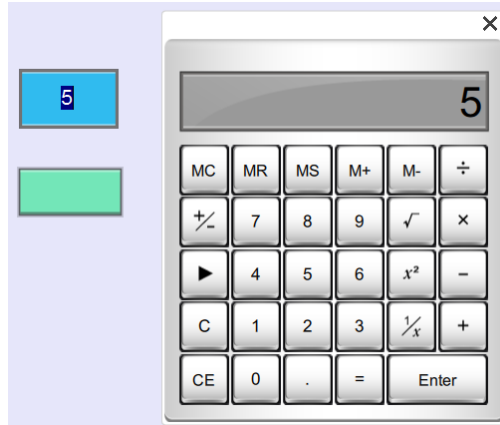

Selecting this option opens [Keep calculation open after paste] checkbox, which keeps the calculator displayed after the value is entered to the object.

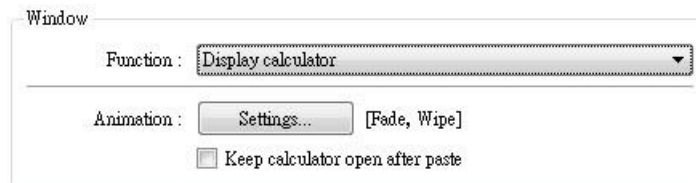

Keyboard Input

Configures the button as a keypad key, and the character it enters, via [Numeric] or [ASCII] objects.

Enter: Same as the keyboard's "Enter" function.

Backspace: Same as the keyboard's "Backspace" function.

Clear: Clear the value in the word register.

Esc: Same as the [Close window] function; it is used to close the keyboard window.

Delete: Same as the keyboard's "Delete" function, deletes the number or character on the right side of the text cursor.

Left: Same as the keyboard's "←" key moves the text cursor to the left side of the previous number or character.

Right: Same as the keyboard's "→" key moves the text cursor to the left side of the next number or character.

Line feed: Move the cursor down to the next line.

Inc: Increment by 1.

Dec: Decrement by 1.

ASCII/UNICODE: Specify the character to be entered by this key.

Execute Macro

Select this check box to execute one of the Macros from the drop down list that has already been configured by users.

 For more information, see “18 Macro References”.

Execute macro Macro :

Window title bar

Function Key defined can be used to move a pop-up window which has no [window title bar] to a preferred position on screen. Select the pop-up window and then click on a preferred position, the window will be moved.

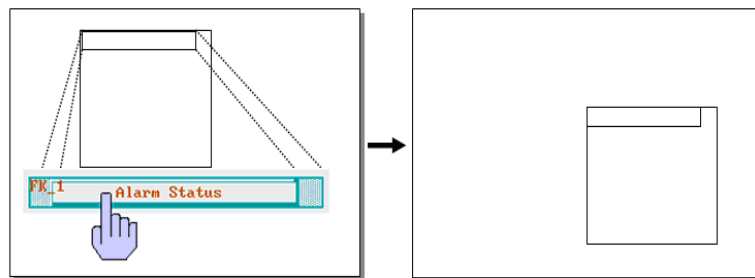

Select the window title bar firstly.

Touching the screen for the new position the popup window will be moved.

Hard copy screen to USB disk, SD card or printer

Print the current window. Before using this function, choose a printer model in [System Parameter Settings] » [Model] » [Printer].

If a monochrome printer is used, selecting [grayscale] can provide a better print result, but the text may not be clearly printed. To improve text printing, avoid using [grayscale].

Hard copy screen to USB disk, SD card or printer

Screen hard copy Printer :

Rotate image 90 degrees Mode :

Crop window

This option can be selected for taking a cropped screenshot.

Acknowledge all events (alarms) (cMT / cMT X Series)

Acknowledge all events once by pressing the Function Key.

Import user data / Use [USB Security Key]

A Function Key can be used to import the e-mail contacts or user accounts set, also, to log in using USB Security Key.

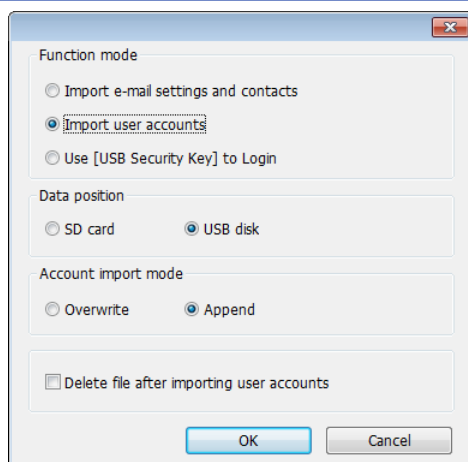

Data Position

Select the external device to store data from [SD card] or [USB disk].

Account import mode

If [Overwrite] is selected, the existing accounts will be overwritten with new accounts in the external device after importing. If [Append] is selected, HMI will append more accounts while the old accounts still exist.

Please note that when [Append] is selected, the accounts that already exist in the project cannot be imported.

Delete file after importing user accounts

If select this check box, the system will delete the account data saved in the external device after importing, this can prevent the account data from leaking out.

Notification

If this selection is enabled, it will notify a designated bit address to set ON or OFF, each time the button is pressed.

Note

- [Overwrite] is the only option when importing the e-mail contacts. This means that all existing contacts will be removed first, and then the new contacts are added.

 For more information, see “6 Window Operations”, “12 Keypad Design and Usage”, “36 Administrator Tools”.

13.6. Toggle Switch

13.6.1. Overview

Toggle Switch object is a combination of Bit Lamp object and Set Bit object. The appearance of the object is controlled by the ON / OFF state of the read bit address. As well, pressing the button sets the value in the bit address according to the settings.

13.6.2. Configuration



Click [Object] » [Toggle Switch] icon on the toolbar to open a Toggle Switch object property dialog. Set up the properties, press OK button, and a new Toggle Switch object will be created.

General Tab

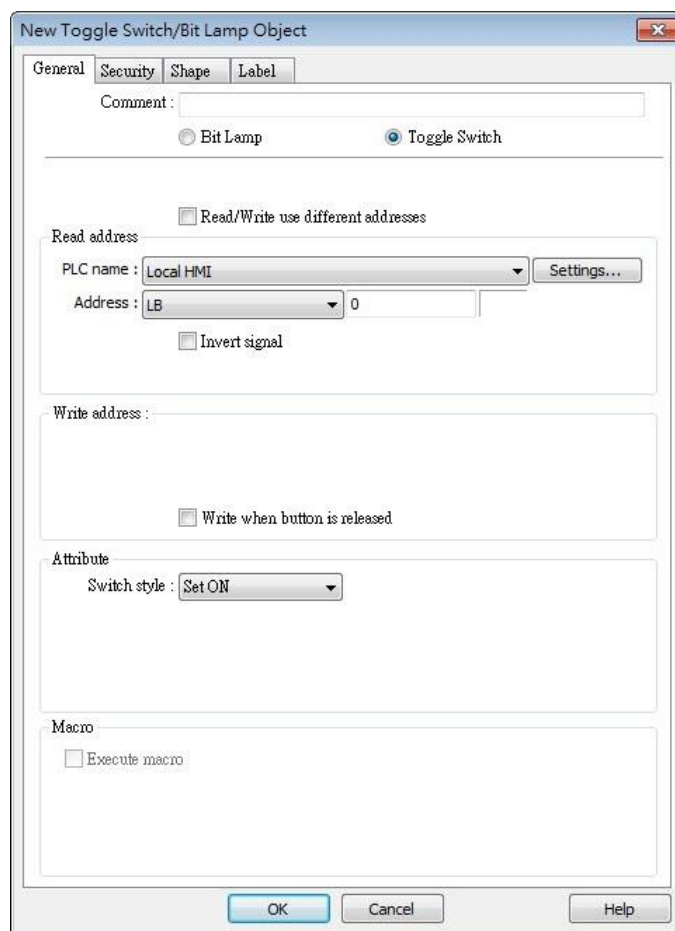

The dialog box titled "New Toggle Switch/Bit Lamp Object" has four tabs: General, Security, Shape, and Label. The General tab is active. It contains the following fields and options:

- Comment: [Text input field]
- Radio buttons: Bit Lamp, Toggle Switch
- Read/Write use different addresses
- Read address section:
 - PLC name: Local HMI (dropdown menu) [Settings... button]
 - Address: LB (dropdown menu) 0 (text input)
 - Invert signal
- Write address: [Text input field]
- Write when button is released
- Attribute section:
 - Switch style: Set ON (dropdown menu)
- Macro section:
 - Execute macro

Buttons: OK, Cancel, Help

Setting	Description	
Comment	User can describe the information of the object.	
	Bit Lamp / Toggle Switch Switch between Bit Lamp and Toggle Switch features.	
Read/Write use different addresses	Different addresses can be used to read data and write data.	
Read address	Click [Setting] to select the [PLC name], [Address], [Device type], [System tag], [Index register] of the bit device that controls the [Toggle Switch] object. Users can also set address in [General] tab while adding a new object. Invert signal Reverses the display of ON / OFF states. For example, if [Invert signal] check box is selected, when the designated bit is OFF, the object displays ON state. When [Read/Write use different addresses] option is not selected, the title of this group box will be "Read/Write address".	
Write address	Click [Setting] to select the [PLC name], [Address], [Device type], [System tag], [Index register] of the bit device that controls the [Toggle Switch] object. Users can also set address in [General] tab while adding a new object. The address can be the same or different from [Read address]. Write after button is released If this function is selected, the action is delayed till button is released, otherwise, the action is executed once the button is pressed. This function does not work with momentary buttons.	
Attribute	Set style	Description
	Set ON	Set ON the designated bit of the device.
	Set OFF	Set OFF the designated bit of the device.
	Toggle	Alternates the bit state each time pressed.
	Momentary	Holds the bit ON only while button is pressed.
Macro	Toggle Switch object can trigger the start of a Macro routine when the Macro has been created in advance.  For more information, see "18 Macro References".	

 **Note**

- When [Execute macro] is selected, the sequence in which the object's write operation and the macro execution is determined by the HMI runtime. In order to exactly arrange the write operation and the macro execution in the desired way, specify the sequence by configuring a Combo Button instead.

13.7. Multi-State Switch

13.7.1. Overview

Multi-state Switch object is a combination of Word Lamp object and Set Word object. The appearance of the object is controlled by the value of the read word address. As well, pressing the button sets the value in the word address according to the settings.

13.7.2. Configuration



Click [Object] » [Multi-State Switch] icon on the toolbar to open a Multi-State Switch object property dialog box. Set up the properties, press OK button, and a new Multi-State Switch object will be created.

General Tab

cMT / cMT X Series

New Multi-State Switch/Word Lamp Object

General Security Shape Label

Comment :

Word Lamp Multi-State Switch

Mode : Value Offset : 0

Read/Write use different addresses

Read address

PLC name : Local HMI Settings...

Address : LW 0 16-bit Unsigned

Error handling...

Write address :

Attribute

Switch style : JOG+ No. of states : 2

Cyclical : Disable

User-defined mapping

Send notification after writing successfully

Enable

OK Cancel Help

eMT, iE, XE, mTV Series

New Multi-State Switch/Word Lamp Object

General Security Shape Label

Comment :

Word Lamp Multi-State Switch

Mode : Value Offset : 0

Read/Write use different addresses

Read address

PLC name : Local HMI Settings...

Address : LW 0 16-bit Unsigned

Write address :

Write when button is released

Attribute

Switch style : JOG+ No. of states : 2

Cyclical : Disable

User-defined mapping

Send notification after writing successfully

Enable

OK Cancel Help

Setting	Description
Comment	User can describe the information of the object. Word Lamp / Multi-State Switch Switch between Word Lamp and Multi-State Switch features.
Model / Offset	Different modes can be selected: [Value], [LSB].  For more information, see "13.2 Word Lamp".
Read/Write use different addresses	Different addresses can be used to read data and write data.
Read address	Click [Setting] to select the [PLC name], [Address], [Device type], [System tag], [Index register] of the word device that controls the Multi-state Switch object. Users can also set address in [General] tab while adding a new object. When [Read/Write use different addresses] option is not selected, the title of this group box will be "Read/Write address".
Write address	Click [Setting] to select the [PLC name], [Address], [Device type], [System tag], [Index register] of the word device that controls the Multi-state Switch object. Users can also set address in [General] tab while adding a new object. Write after button is released If this function is selected, the action is delayed till button is released; otherwise, the action is executed once the button is pressed.
Attribute	Switch style Select the object's operation mode, see Example 1. User-defined mapping The value placed in the write register of each selection, the action taken when an illegal value is entered, and error notification to a designated bit address can be set.

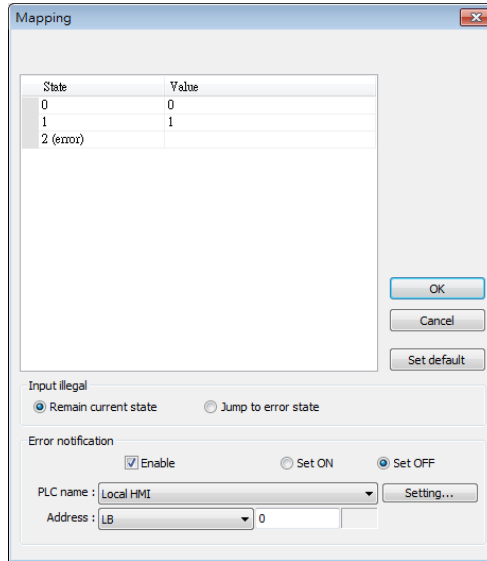

Remain current state

If an illegal value is entered, Multi-state Switch will remain at the current state.

Jump to error state

If an illegal value is entered, Multi-state Switch will jump to the error state.

Error notification

If an illegal value is entered, automatically set the value placed in the designated register.

Send

notification after writing successfully

After the system successfully writes data to PLC, the designated bit address will be set On/Off.

Error handling (cMT / cMT X Series)

The action taken when an illegal value is entered or notify a designated bit address. This is similar to [User-defined mapping]; the difference is the value corresponding to each state need not to be preset.

Example 1

- JOG+

Increase the value of a designated register by 1 each time when pressing the button, till the value equals to [No. of states]. A cyclic action can be enabled. As shown below, each time when pressing the button, the state number will add 1 start from state 0, till state 4 ([no. of state]-1), and returns to 0 and step up again.

Attribute

Switch style : JOG+ No. of states : 5

Cyclical : Enable

User-defined mapping

- JOG-

Decrease the value of the designated register by 1 each time when pressing the button, till the value equals to 0. A cyclic action can be enabled. As shown below, each time when pressing the button, the state number will minus 1 start from state 4 ([no. of state]-1), till state 0, and returns to state 4 and step down again.

Attribute

Switch style : JOG- No. of states : 5

Cyclical : Enable

User-defined mapping

13.8. Slider

13.8.1. Overview

Slider object is used to change the value in a designated word register address by moving the slide on the screen.

13.8.2. Configuration



Click [Object] » [Slider] icon on the toolbar to open a Slider object property dialog box. Set up the properties, press OK button, and a new Slider object will be created.

General Tab

cMT / cMT X

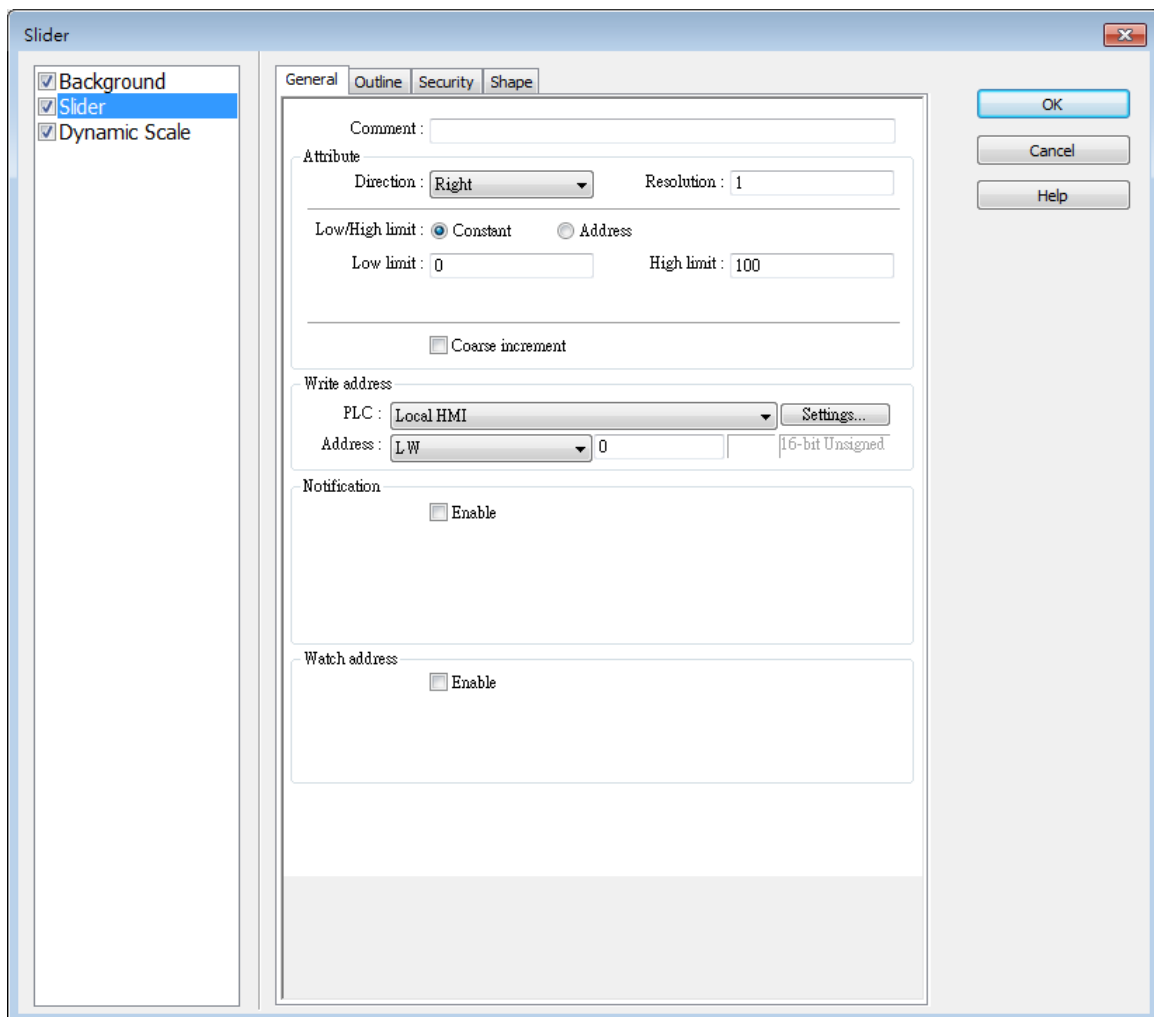

The image shows the 'Slider' configuration dialog box. On the left, there is a list of options: 'Background' (checked), 'Slider' (checked), and 'Dynamic Scale' (checked). The main area is divided into several sections:

- General** (selected tab):
 - Comment: [Empty text box]
 - Attribute:
 - Direction: [Right] (dropdown)
 - Resolution: [1] (text box)
 - Low/High limit: Constant Address
 - Low limit: [0] (text box) High limit: [100] (text box)
 - Coarse increment
- Write address**:
 - PLC: [Local HMI] (dropdown) [Settings...] (button)
 - Address: [LW] (dropdown) [0] (text box) [16-bit Unsigned] (text)
- Notification**:
 - Enable
- Watch address**:
 - Enable

On the right side of the dialog, there are three buttons: 'OK', 'Cancel', and 'Help'.

eMT, iE, XE, mTV

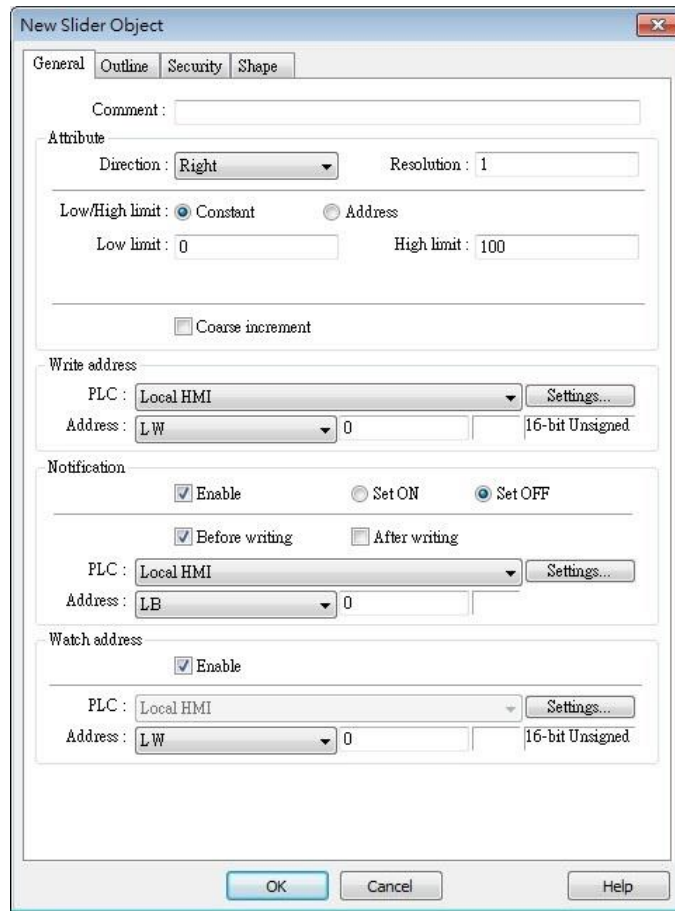

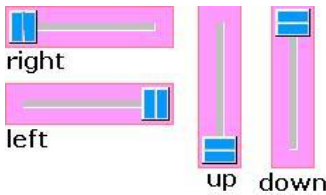
Setting	Description
Attribute	<p>Direction Select the direction of the slider. (Right, Up, Left, Down)</p>  <p>Resolution Sets the value change in the word register for each step of the Slider. For example, if set to 10, the register value changes by 10 points for each increment or decrement on the Slider.</p> <p>Constant Sets the range of the Slider. For example, If set [Low limit] to 5, and [High limit] to 100, the Slider will enter values between 5 and 100.</p> <p>Address Set the [Low/High limit] by a designated register, see Example 1.</p> <p>Coarse increment Apart from moving the roller to change the value as in [Resolution],</p>

	if this option is selected, the word value will increase / decrease by the [Increment] value each time the object is touched.
Write address	Click [Setting] to select the [Device], [Address], [Device type], [System tag], [Index register] of the word device that controls the Slider object. Users can also set address in [General] tab while adding a new object.
Notification	<p>If enabled, the state of a designated bit address will be set to ON or OFF before or after writing.</p> <p>Click [Setting] to select the [Device], [Address], [Device type], [System tag], [Index register] of the bit device that controls the notification settings. Users can also set address in [General] tab while adding a new object.</p> <p>[Before writing] / [After writing]</p> <p>Change the state of a designated bit register before, or after the slider is slid.</p>
Watch address	When moving the roller, the new value written to the word register address can be displayed in real time.

Example 1

Set the low or high limit by a designated register. When write address is LW-n, where n is an arbitrary number, the rule of setting limits is:

Content	16-bit	32-bit	64-bit (cMT / cMT X only)
Address	LW-n	LW-n	LW-n
Low limit	LW-n	LW-n	LW-n
High limit	LW-n+1	LW-n+2	LW-n+4

When address is LW-100, the rule of setting limits is:

Content	16-bit	32-bit	64-bit (cMT / cMT X only)
Address	LW-100	LW-100	LW-100
Low limit	LW-100	LW-100	LW-100
High limit	LW-101	LW-102	LW-104

Outline Tab

cMT / cMT X Seires

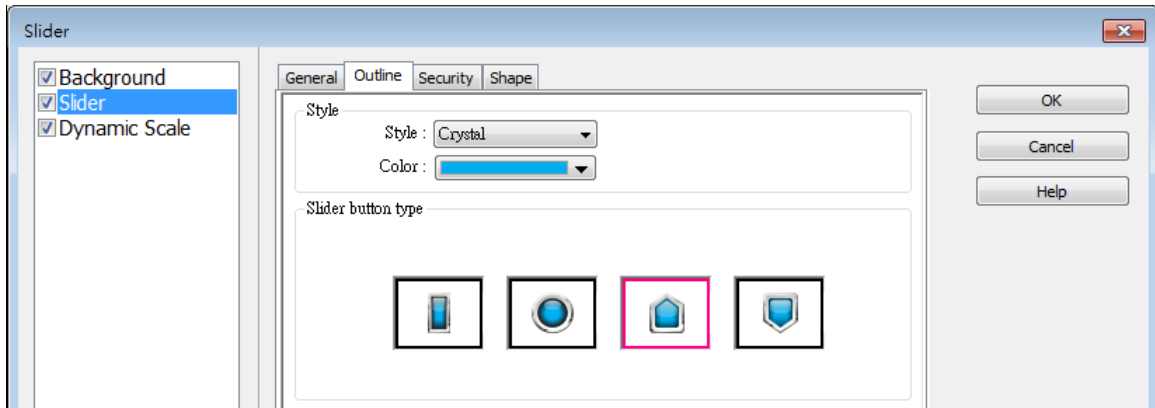

eMT, iE, XE, mTV Seires

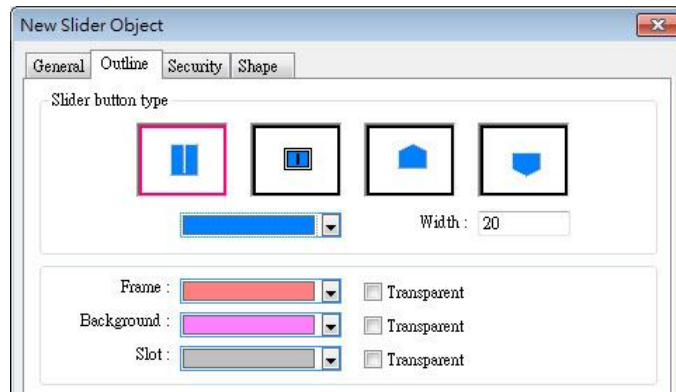

Setting	Description
Slider button type (cMT / cMT X)	Select slider button type, by default, a picture selected from the Picture Library can be the slider button.
Slider button type (eMT, iE, XE, mTV)	Four default styles are offered, and the width and color of the Frame, Background, Slot can be set.

13.8.3. Combo Setting

cMT / cMT X Series HMI support combo setting for Slider, which allows setting of multiple related objects at a time. Slider can be set with Background and Dynamic Scale.

Background

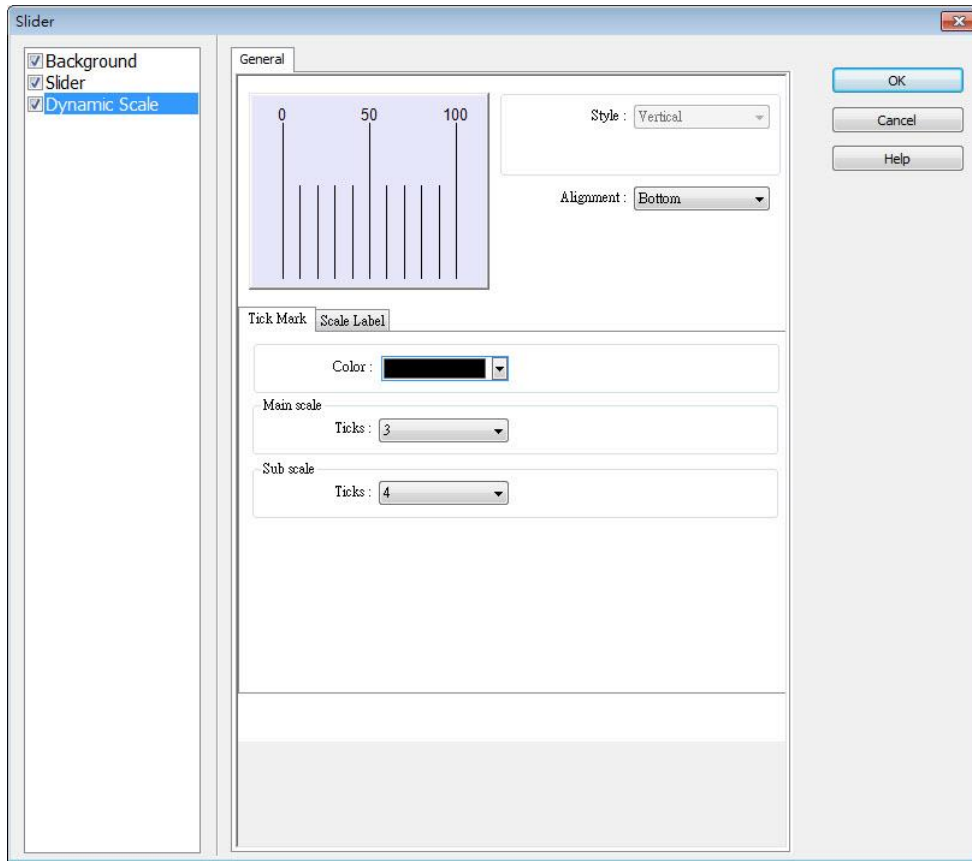

Setting	Description
Margin	Specify the space between the background edge and the objects.

Color/Style	Customize

Select a suitable background pattern and color.

Picture



Use the default picture or choose a picture from Picture Library.

Dynamic Scale

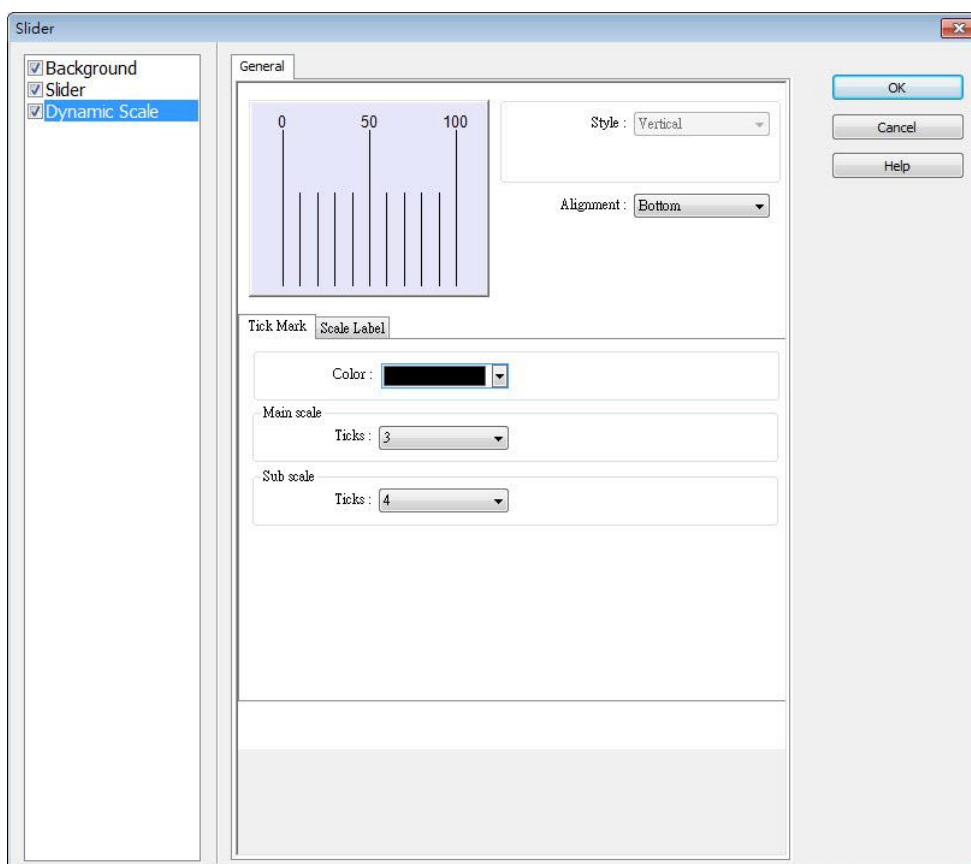

Setting	Description
Style	The scale style will follow the Slider.
Alignment	The position of the scale bar along the Slider.
Tick Mark	Configure the number of tick marks for main and sub scales, and the color of tick marks.
Scale Label	<p>Configure the font, font color, font size and other attributes of scale label.</p> <p>In Slider settings if [Address] is selected for Low/High limit, then Scale Label's [Dynamic limits] will be set automatically.</p> <p>In Slider settings if [Left] is selected for Direction, then Scale Label's [Reverse (Left/Right)] will be set automatically.</p>

Tick Mark | Scale Label

Use scale label

Font: Arial

Color: Size: 10

Left decimal Pt.: 4 Right decimal Pt.: 0

Position: Top

Dynamic limits

Reverse (Left/Right)

Left: LW-1 Right: LW-0

13.9. Numeric

13.9.1. Overview

Numeric object can be used to input or display the value of a designated word register.

13.9.2. Configuration



Click [Object] » [Numeric] icon on the toolbar to open a Numeric object property dialog box. Set up the properties, press OK button, and a new Numeric object will be created.

General Tab

cMT, cMT X Series

eMT, iE, XE, mTV Series

Setting	Description
Allow input	If selected, the input features and relevant settings are enabled.
Read / Write	Different addresses can be used to read data and write data.

use different address	
Read address	Click [Setting] to select the [Device], [Address], [Device type], [System tag], [Index register] of the word device that displays the value. Users can also select a tag defined in Address Tag Library. When [Read/Write use different addresses] option is not selected, the title of this group box will be "Read/Write address".
Write address	Select the [Device], [Device type], [Address] of the word device that system writes to.
Notification	<p>With notification enabled, the state of the designated bit address can be set on / off, before / after writing.</p> <p>Notification works differently comparing cMT / cMT X Series with eMT/iE/XE/mTV Series.</p> <p>cMT/cMT X Series: Trigger the object to open a keyboard window » Notification before writing » Enter a value and press ENTER » Start writing operation » Notification after writing.</p> <p>eMT/iE/XE/mTV Series:</p> <p>Trigger the object to open a keyboard window » Enter a value and press ENTER » Notification before writing » Start writing operation » Notification after writing.</p>
Notification on invalid input	If an illegal value is entered, automatically set the state of a designated register.

Data Entry Tab

cMT, cMT X

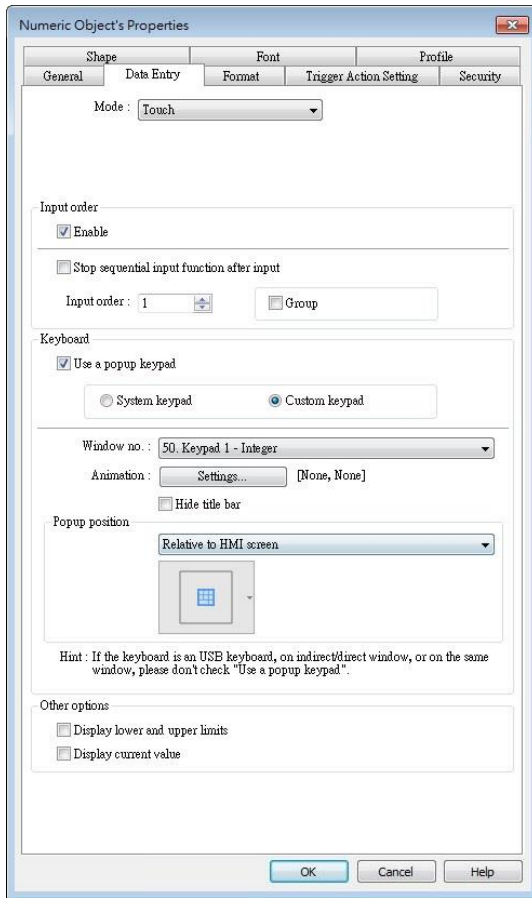

eMT, iE, XE, mTV Series

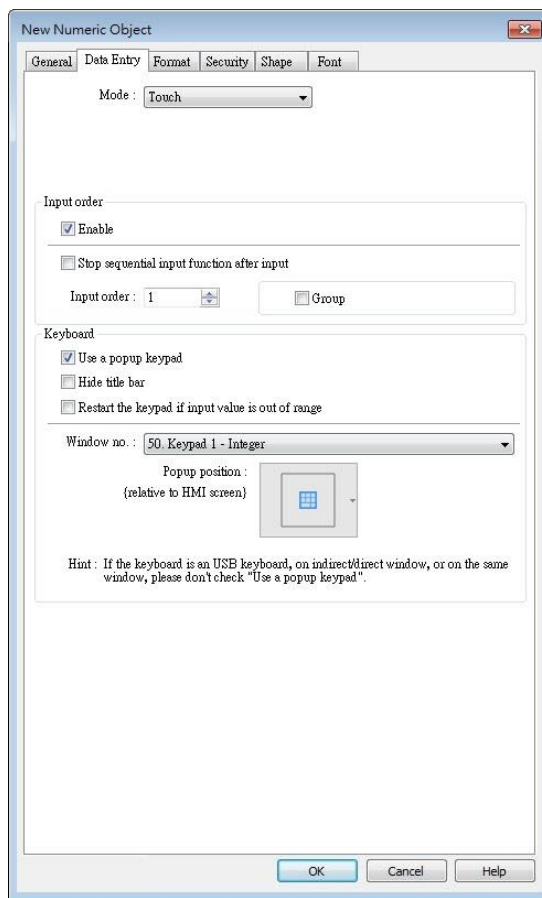

Setting	Description
Mode	Touch Used when data entry is initiated by touching the screen object.
	Bit control Used when data entry is enabled by turning ON a designated bit, and entry ends when the bit goes OFF.
Input control	Specify a bit address that enables or ends data entry. The order of data entry is specified in [Input order] and an external USB keyboard is needed for data entry. For cMT-SVR, use cMT Viewer's keyboard.
Input order	Perform continuous input by setting [Input order] and [Group]. The criterion of searching the next input object: <ul style="list-style-type: none"> • The range of [Input order]: 1 ~ 511, range of [Group]: 1 ~ 15. • If [Group] is not selected, its input order is 0. • The system only searches for the objects within the same

Group.

- The lower number of order is entered before the higher number of order.
- For multiple objects within the same group and with the same input order, the object placed in the lower layer is entered first.

Keyboard

Use a popup keypad

If selected: A pre-designed pop-up keypad can be chosen by selecting a check box and selecting the relative position on the HMI screen. When data entry is enabled, the pop-up keypad displays in the selected position, and closed when data entry ends.

If not selected: When data entry is enabled, the pop-up keypad is not displayed. Users may:

- Create a custom design on the same screen window.
- Use a USB keyboard.

System keypad

cMT / cMT X Series model has its own system keypad, select this checkbox to use the system keypad, or select [Custom keypad] to set up a customized keypad.

Animation Setting

When using a cMT / cMT X Series model with [Custom keypad] selected, the transition effect of the keypad window can be selected.

 See Chapter 13.5 Function Key in this manual for the list of effects.

Hide title bar

Use a keypad without the title bar.

Popup position

When using a cMT / cMT X Series model with [Custom keypad] selected, the position where the keypad pops up can be selected.

The position can either be relative to HMI screen or relative to object.

Relative to HMI screen

Relative to object

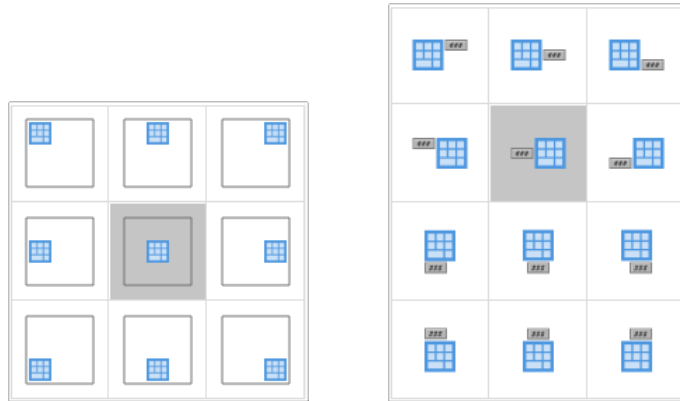

Restart the keypad if input value is out of range

When entering data, if the value entered is not within the valid range, the system will automatically restart the keypad.

Other options

(For cMT / cMT X Series)

Display lower and upper limits

If selected, when entering a value, the range is displayed near the object.

Display previous value

If selected, when entering a value, the value before update is displayed near the object.



 To create a keyboard in current window, see “12 Keypad Design and Usage”.

Example 1

This example demonstrates how to use [Input Order] and [Group] to perform continuous input in several Numeric objects. After entering data in one object, entry will be passed to the next input order object which is in the same group.

1. Create three Numeric objects, and set [Input order] to 1, 2, and 3 respectively. Include the three objects in [Group 1] as shown in the following figure.

LW-0

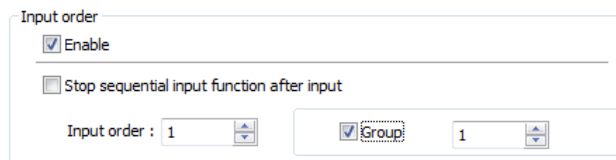

LW-1

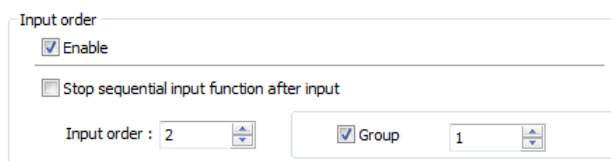

LW-2

Input order

Enable

Stop sequential input function after input

Input order : 3

Group 1

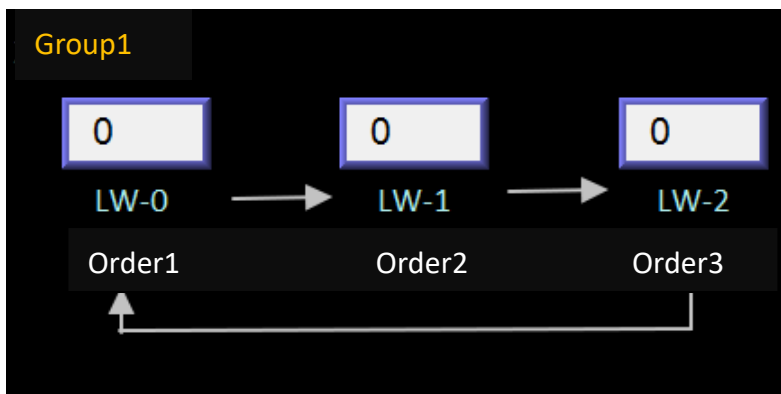

2. When finish entering data in the last object, to end data entry of all objects, please select [Stop sequential input function after input] check box.

Input order

Enable

Stop sequential input function after input

Input order : 3

Group 1

Format Tab

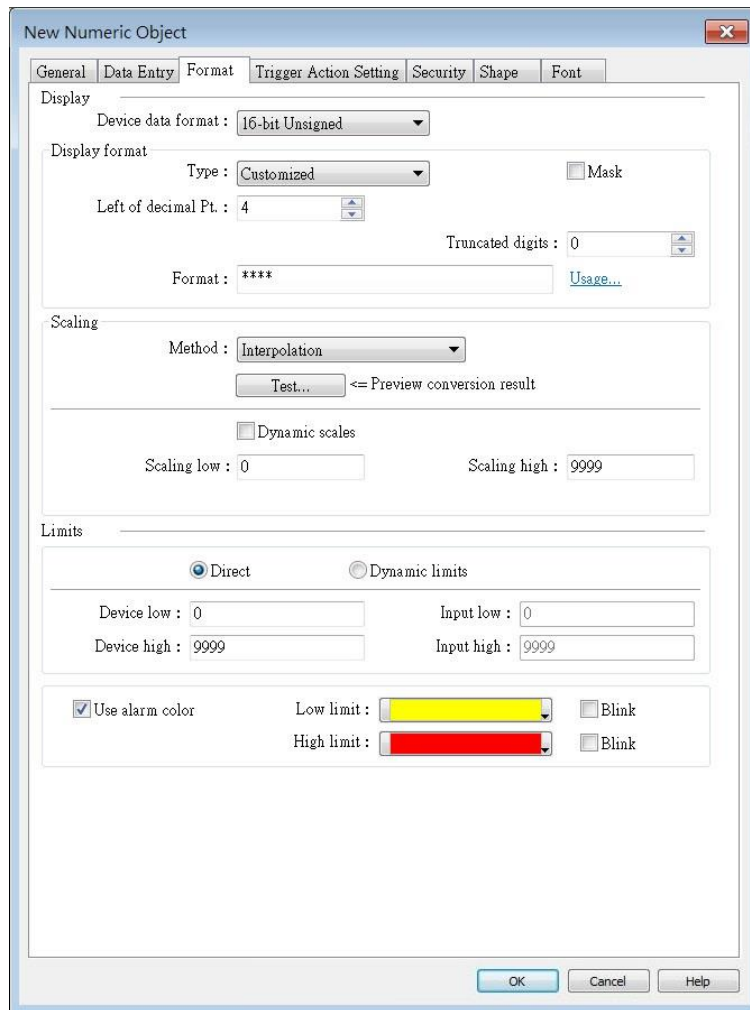

Setting	Description
Device Data Format	Set the data format of a designated word register. Options include: BCD, Binary, Unsigned, Signed, HEX, and Float. 16-bit uses 1 word where 32-bit uses two words.
Mask	If selected, any values entered will be hidden by displaying them as asterisks “*”.
Display format	<p>Default General Numeric formats.</p> <p>Customized Each “*” sign represents each integer digit, and each “#” sign represents each fraction digit that will be displayed in the Numeric object. Float and Double formats are only supported on cMT / cMT X models.</p>

Apart from “*” signs, extra texts can be entered in the [Format] field, for example: kg. The available alignment options are: [Left], [Center], [Right], [Leading zero].

The numeric value represented by “*” sign will be displayed from the highest digit to the lowest in the Numeric object.

Truncated digits

Specify the number of digits to be truncated, from the lowest digit to the highest.

The number of “*” signs = [Left of decimal Pt.] - [Truncated digits] - [Right of decimal Pt.].

The number of “#” signs = [Right of decimal Pt.] - [Truncated digits].

Please see the following examples:

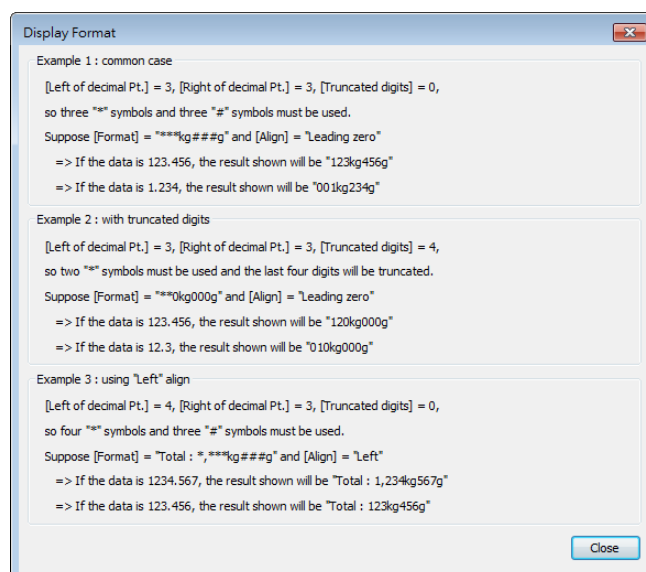
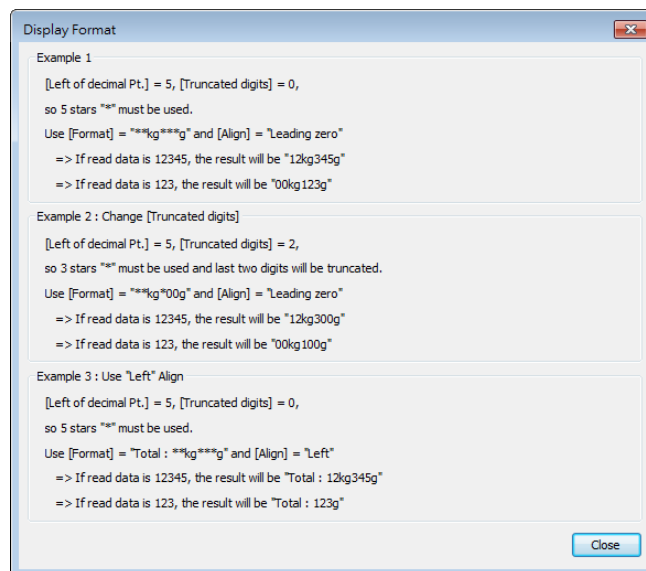

When leading zero is not used, the text enclosed in two “*” signs

will not show, for example:

[Left of decimal Pt.] = 5, [Truncated digits] = 0, and Display Format is "Total=**kg***g"

If the data read is 255, the result would be: "Total=255g"

If the data read is 1000, the result would be: "Total=1kg000g"

Scientific Notation (cMT / cMT X Series)

Express numerical data using scientific notation; for example, number 100 is displayed as 1e+2. Scientific notation is not available for device data formats: BCD, HEX, or Binary.

Number of digits

Left of decimal Pt.

The number of digits before the decimal point.

Right of decimal Pt.

The number of digits after the decimal point.

Scaling

Interpolation

If this check box is selected, [Engineering low] and [Engineering high] boxes appear. Values entered in these boxes correspond to the display range required. The setting also requires [Input low] and [Input high] in the limits section. See Example 2.

Test: Preview the result of Interpolation. See Example 2.

Dynamic scales: Set the [Engineering low] and [Engineering high] by a designated register. See Example 4.

Macro subroutine

The value read from or written to the register can be computed by macro subroutines selected in [Read conversion] and [Write conversion]. The macro subroutines should be defined in Macro Function Library. To use this feature, see "13.9.2.1 The rule of using Macro subroutine".

Limits

This section enables users to apply display limits to the values in the input register and set the display color to be used when the register value falls outside the specified limits.

Direct

Set the limits by entering values in [Device low] and [Device high].

If the value entered is outside the limits, the value in the register cannot be changed.

Dynamic limits

Set the limits by specifying a register.

To use consecutive addresses, see Example 5.

On a cMT / cMT X model with the [Use different addresses] option

selected, it's possible to set the high and low limits by specifying different addresses. If the scaling method used is interpolation, both high and low limit addresses are required.

**Use alarm
color**

Low limit

When the value in the register is outside the [Low limit], the object displays digits by using the set color.

High limit

When the value in the register is outside the [High limit], the object displays digits by using the set color.

Blink

When the value in the register is outside either limit, the digits flash.

Trigger Action Setting (cMT / cMT X)

Actions executed before/after writing can be classified into action groups. The groups are put in sequence. The actions within the same group are executed at the same time. When all the actions within the same group are completed, the actions in the next group are then executed. Compared to the Notification actions selected in General tab, Trigger Action Setting offers more flexible combination of actions. For more details about these settings, please also see Action Trigger in Chapter 13.

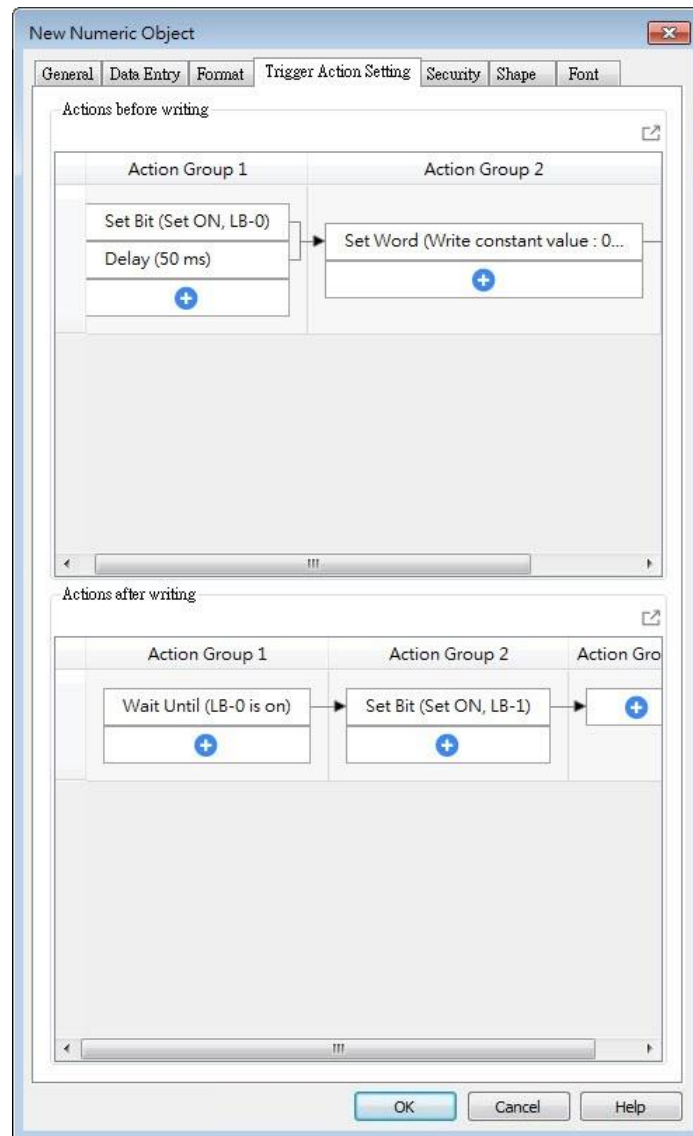

Setting	Description
Actions before writing	The predefined action groups will be executed once the write operation starts, and will not wait for it to be completed.
Actions after writing	The predefined action groups will be executed when the write operation is completed.

13.9.2.1. The rule of using Macro Subroutine

- There must be a return value and exactly one parameter.

Examples:

```
sub char test (short a) // (Correct)
```

```
sub test (char a) // (Incorrect, no return value.)
```

```
sub char test (char a, char b) // (Incorrect, two parameters.)
```

- Use the Macro data type that corresponds to the object's data format.

The mapping is as follows:

Macro Data Type	Numeric Object Data Format
short	16-bit Signed
Int	32-bit Signed
unsigned short	16-bit BCD, 16-bit HEX, 16-bit Binary, 16-bit Unsigned
unsigned int	32-bit BCD, 32-bit HEX, 32-bit Binary, 32-bit Unsigned
float	32-bit Float
long	64-bit Signed (cMT / cMT X only)
unsigned long	64-bit Unsigned (cMT / cMT X only)
double	64-bit Double (cMT / cMT X only)

For example, if the data format of the numeric object is 16-bit Unsigned, only the corresponding Macro data type: unsigned short, is available.

Examples:

```
sub char test(unsigned short a) // (Correct)
sub char test(char a) // (Incorrect)
```

- Supports only the local HMI address.

Examples:

```
GetData(var, "Local HMI", LB, 0, 1) // (Correct)
GetData(var, "MODBUS RTU", 0x, 0, 1) // (Incorrect)
```

- The following system defined functions are unable to be invoked:

ASYNC_TRIG_MACRO, SYNC_TRIG_MACRO, DELAY, FindDataSamplingDate, FindDataSamplingIndex, FindEventLogDate, FindEventLogIndex, INPORT, INPORT2, OUTPORT, PURGE, TRACE

- The following statements are not supported:

For-Next, While-Wend

Example 2

If [Interpolation] is selected, the scaling equation is as the following:

If A indicates the original data and B indicates the displayed data:

$$B = [\text{Engineering low}] + (A - [\text{PLC low}]) \times \text{Ratio}$$

where, Ratio = $([\text{Engineering high}] - [\text{Engineering low}]) / ([\text{PLC high}] - [\text{PLC low}])$

As shown below, the original data is 15, after conversion, 40 will be displayed.

Scaling

Method :

<= Preview conversion result

Dynamic scales

Engineering low : Engineering high :

Limits

Direct Dynamic limits

PLC low : PLC high :

Input low : Input high :

Click [Test] button to preview the result of Interpolation. Enter a value in [PLC] field as shown in the following figure, for example, enter value 15, and the result, which is 40, will be displayed.

Conversion Test

Number of digits

Left of decimal Pt. : Right of decimal Pt. :

HMI Engineering low PLC PLC low Engineering high Engineering low

= + (-) x $\frac{\text{Engineering high} - \text{Engineering low}}{\text{PLC high} - \text{PLC low}}$

PLC high PLC low

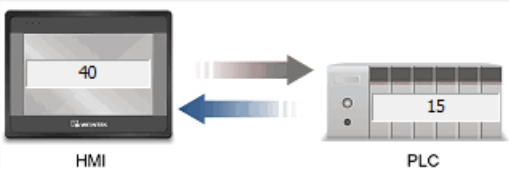

HMI PLC

Example 3

If the numeric format selected is not Float and decimal point is used, the decimal place of the converted result will not be adjusted automatically, please adjust [Engineering high] to correctly place the decimal point of the result gained in [Interpolation] mode. Please see the illustration below.

1. Create two Numeric objects, set [Right of decimal Pt.] to 1 and select [Interpolation] method for one of the objects as shown in the following figure.

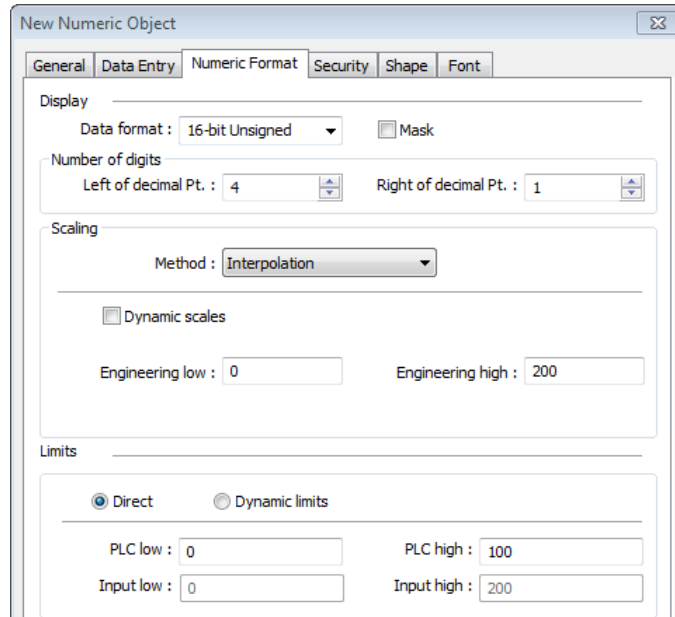

- Enter value “123”, the object set to [Interpolation] displays “246.0” instead of “24.6”.



- To move the decimal point one place to the left, adjust [Engineering high] as shown in the following figure.

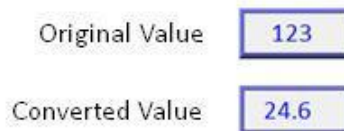
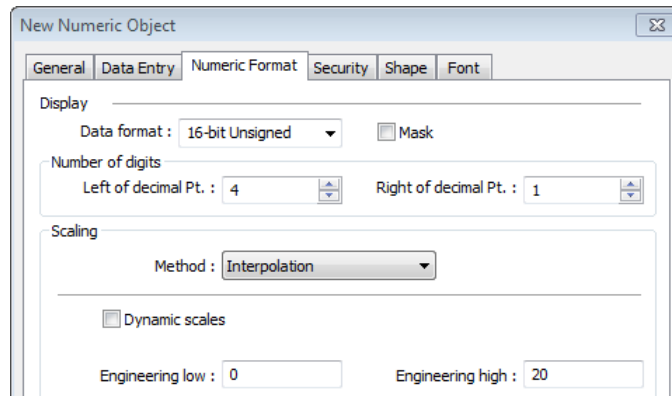

Example 4

If [Interpolation] is selected, set the [Engineering low] and [Engineering high] by a designated register. When Dynamic Address is LW-n, where n is an arbitrary number, the rule of setting [Engineering low] and [Engineering high] is:

Content	16-bit	32-bit	64-bit (cMT / cMT X only)
Dynamic address	LW-n	LW-n	LW-n
Engineering low	LW-n	LW-n	LW-n
Engineering high	LW-n+1	LW-n+2	LW-n+4

When address is LW-100, the rule of setting limits is:

Content	16-bit	32-bit	64-bit (cMT / cMT X only)
Dynamic address	LW-100	LW-100	LW-100
Engineering low	LW-100	LW-100	LW-100
Engineering high	LW-101	LW-102	LW-104

Example 5

Set the limits by a designated register. When [Address] is LW-n and [Use consecutive addresses] is selected, the rule of setting limits is:

Content	16-bit	32-bit	64-bit (cMT / cMT X only)
Address	LW-n	LW-n	LW-n
Low limit	LW-n	LW-n	LW-n
High limit	LW-n+1	LW-n+2	LW-n+4

When address is LW-100, the rule of setting limits is:

Content	16-bit	32-bit	64-bit (cMT / cMT X only)
Address	LW-100	LW-100	LW-100
Low limit	LW-100	LW-100	LW-100
High limit	LW-101	LW-102	LW-104

Example 6

The following demonstrates how to use [Macro subroutine] for scaling when configuring Numeric object.

The following two macros are used, one for [Read conversion] and one for [Write conversion].

Read Conversion

```
sub short read(short a)

short b
b = a + 10
return b

end sub
```

Write Conversion

```
sub short write(short a)

short b
b = a - 10
return b

end sub
```

1. Create two Numeric objects: NE_0 and NE_1 and use the same control address. Select [Macro subroutine] for NE_1.

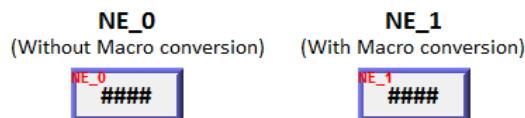

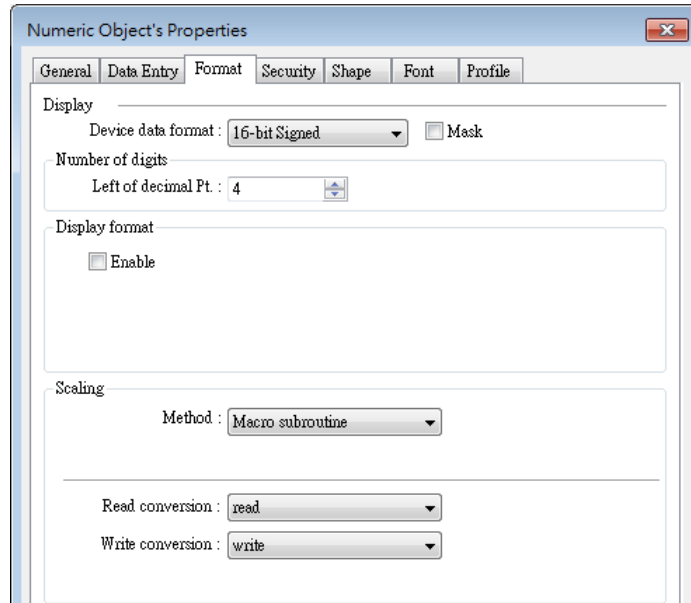

2. Enter 0 in NE_0 then NE_1 will execute [Read conversion]. The value gained will be 10.

NE_0 (Without Macro conversion)	NE_1 (With Macro conversion)
0	10

Read Conversion

```
sub short read(short a)

short b
b = a + 10
return b

end sub
```

Write Conversion

```
sub short write(short a)

short b
b = a - 10
return b

end sub
```

3. Enter 80 in NE_1, [Write conversion] is executed and the value gained will be 70. NE_0 displays 70.

NE_0 (Without Macro conversion)	NE_1 (With Macro conversion)
70	80

Read Conversion

```
sub short read(short a)

short b
b = a + 10
return b

end sub
```

Write Conversion

```
sub short write(short a)

short b
b = a - 10
return b

end sub
```

 **Note**

- If executing [Read conversion] and [Write conversion] by the same numeric object, the value entered in this object is computed by the Macro subroutine of [Write conversion] first, and then the result is computed by the Macro subroutine of [Read conversion]. In Example 5, if the subroutine of [Write conversion] is set to $b=a-20$, then entering 80 in NE_1 will get 60 after [Write conversion] and then the object displays 70 after [Read conversion].

Security Tab

cMT, cMT X

eMT, iE, XE, mTV Series

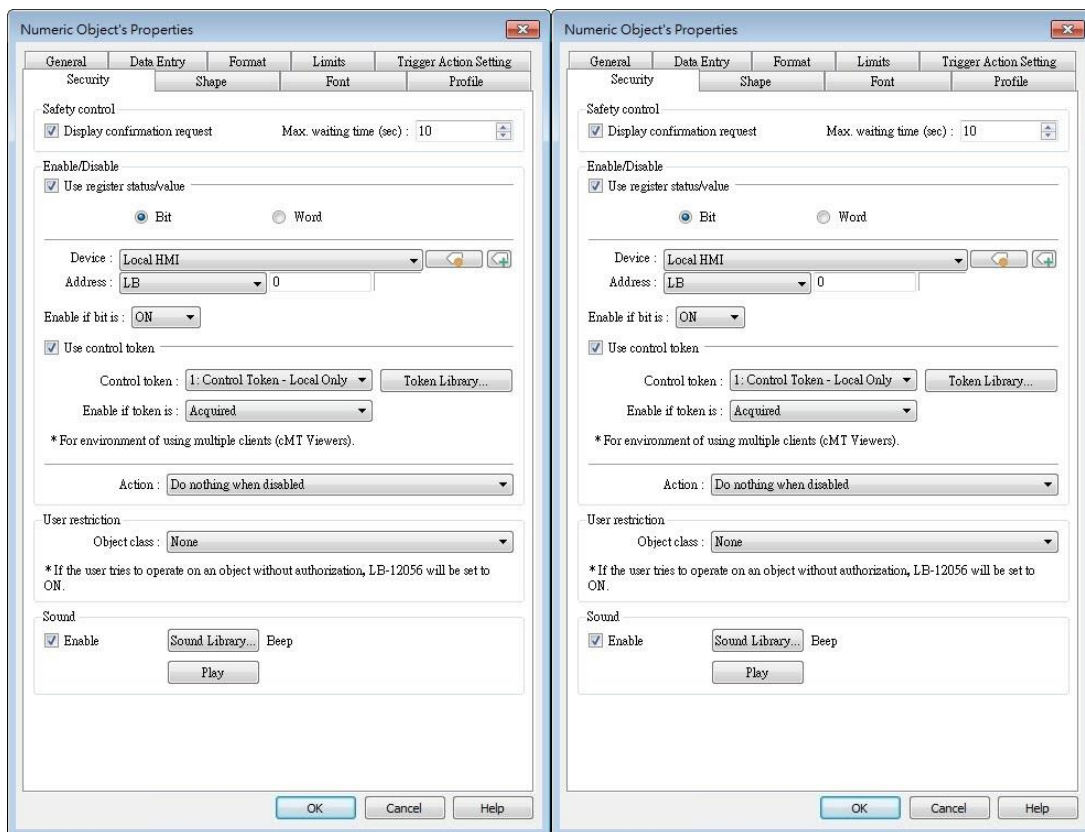

Setting

Description

Safety control

Displays a confirmation request window before executing a command.

Enable/Disable

Use register status / value

With this option selected, whether an object is operable depends on whether the specified condition occurs in the designated address.

Use control token

With this option selected, whether an object is operable depends on whether a control token is acquired or

unacquired.

Action modes:

Do nothing when disabled

The object is not operable, and its status remains unchanged when the specified condition does not occur in the designated address.

Hide when disabled

The object is hidden when the specified condition does not occur in the designated address.

Grayed label when disabled

The value in the object turns gray when the specified condition does not occur in the designated address.

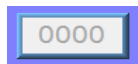

User restriction

Set the security class of the object to be operated by an authorized user.

Sound

When enabled, the selected sound will be played when the object is touched.

Font Tab

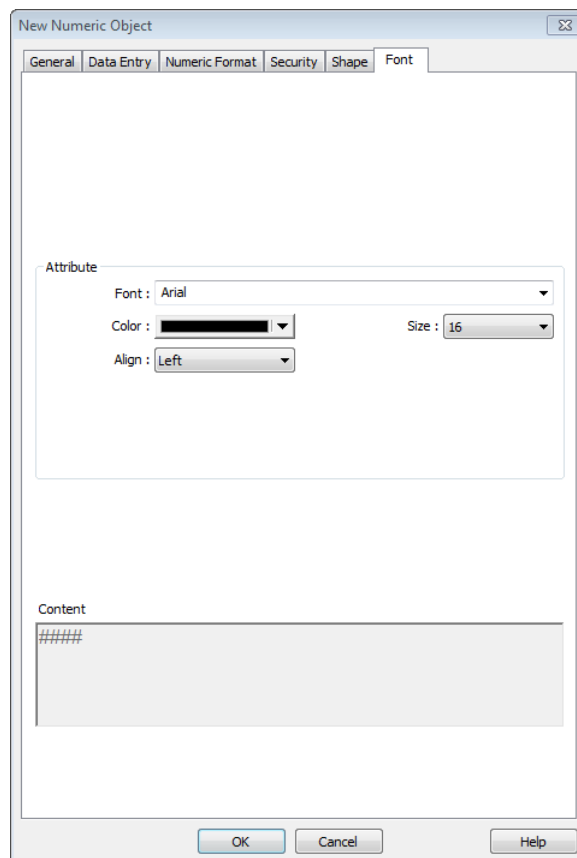

Setting

Description

Color	When the value is within the limits, display digits using color set in this tab.
Align	<p>Left: Align the number to the left.</p> <p>Center: Align the number to the center.</p> <p>Right: Align the number to the right.</p> <p>Leading zero: The number is preceded with leading zeros when the number of digits is less than that set.</p> <p>Left <input type="text" value="66"/></p> <p>Center <input type="text" value="66"/></p> <p>Right <input type="text" value="66"/></p> <p>Leading zero <input type="text" value="0066"/></p>
Size	Set the font size.

13.10. ASCII

13.10.1. Overview

ASCII object can be used to input or display ASCII or UNICODE characters held in designated word registers.

13.10.2. Configuration



Click [Object] » [ASCII] icon on the toolbar to open an ASCII object property dialog box. Set up the properties, press OK button, and a new ASCII object will be created.

General Tab

cMT, cMT X

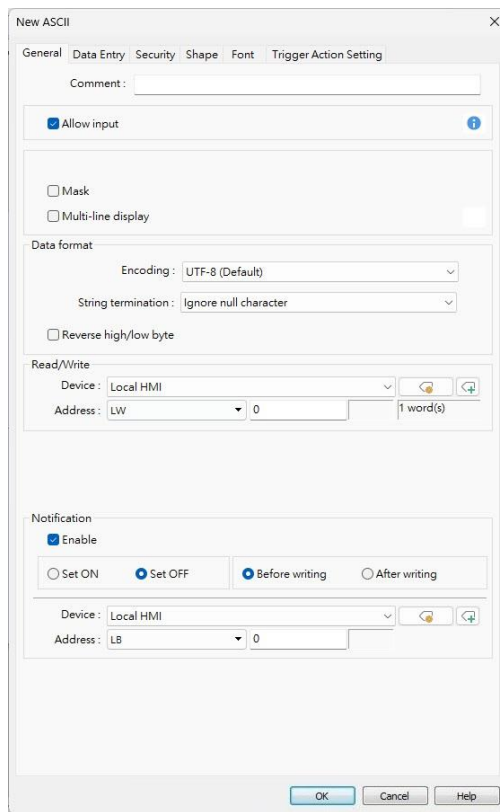

eMT, iE, XE, mTV Series

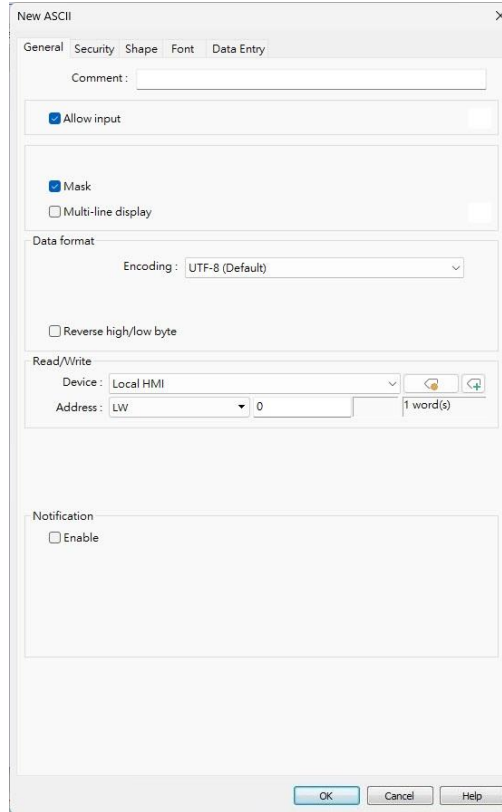

Setting	Description
Allow input	If selected, the input features and relevant settings are enabled.
Mask	If selected, any values entered will be masked by asterisks (*).
Multi-line display	If selected, the ASCII object can display multi-lined text. If a line feed character LF (0xA) is used in the string, a newline will be

	created.
Vertical alignment	When [Multi-line display] is enabled, the method to vertically align multiple lines of text can be selected.
Encoding	Select encoding from UTF-8 (default), Unicode, or Latin-1.
String termination	Ignore null character, or treat the first encountered \0 as the end of the string.
Reverse high/low byte	Normally an ASCII code is displayed in “high byte”, “low byte” order. Reverse selection makes the system display ASCII characters in “low byte”, “high byte” order.



The left object is in normal form, and another is high/low byte reversed.

Read address	Click [Setting] to select the [PLC name], [Address], [Device type], [System tag], [Index register] of the word device that displays characters. Users can select a defined address tag from Address Tag Library, or set address in [General] tab while adding a new object.
---------------------	---

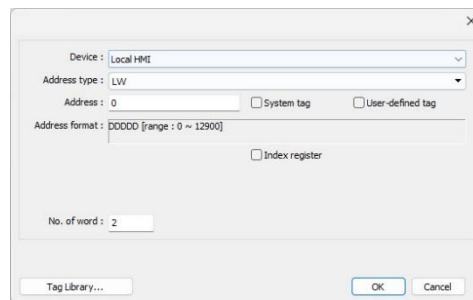

No. of words

Select the maximum number of words to be displayed.

cMT / cMT X Series: max. 160 words

eMT/XE/mTV/iP: max. 64 words

Notification	<p>With notification enabled, the state of the designated bit address can be set on / off, before / after writing.</p> <p>Notification works differently comparing cMT/cMT X Series with eMT/iE/XE/mTV Series.</p> <p>cMT/cMT X Series: Trigger the object to open a keyboard window » Notification before writing » Enter a value and press ENTER » Start writing operation » Notification after writing.</p> <p>eMT/iE/XE/mTV Series:</p> <p>Trigger the object to open a keyboard window » Enter a value and press ENTER » Notification before writing » Start writing operation</p>
---------------------	---

» Notification after writing.

 **Note**

- A UNICODE character uses 1 word, and an ASCII character uses 1 byte. Therefore 1 word can be used as 1 UNICODE character or 2 ASCII characters. (1 word equals to 2 bytes)

Font Tab

cMT, cMT X

eMT, iE, XE, mTV Series

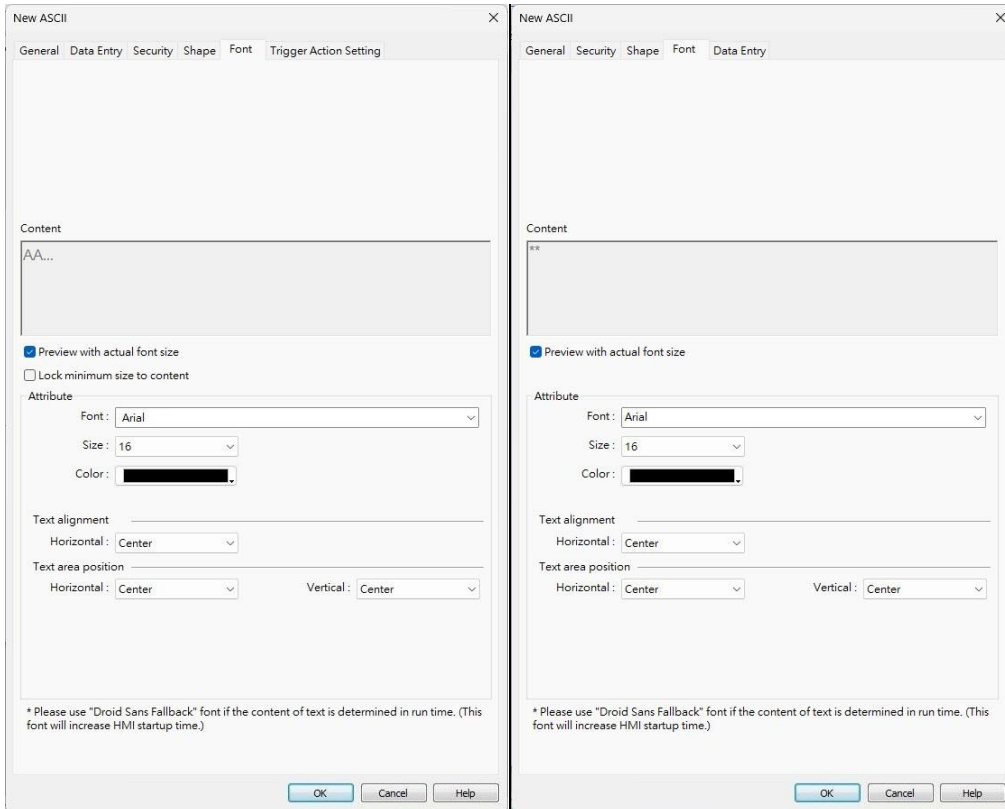

Setting	Description
Preview with actual font size	Preview in the Content field based on the font and size settings specified in the Attribute.
Lock minimum size to content	If selected, the ASCII object's width automatically adjusts to the minimum width necessary to display all the text.
Attribute	The font, size, color, and alignment can be set.
Text Alignment	Multiline text is aligned within the label outline. The method to align multiple lines of text can be selected.
Text area position	Multiline text is aligned within the object outline. The label outline is highlighted by red dotted line and the object outline is highlighted by blue dotted line. Please note that this

feature is ineffective when [Multi-line display] is enabled in General tab.

When object is selected.	When text is selected.

Trigger Action Setting (cMT / cMT X)

Actions executed before/after writing can be classified into action groups. The groups are put in sequence. The actions within the same group are executed at the same time. When all the actions within the same group are completed, the actions in the next group are then executed. Compared to the Notification actions selected in General tab, Trigger Action Setting offers more flexible combination of actions. For more details about these settings, please also see Action Trigger in Chapter 13.

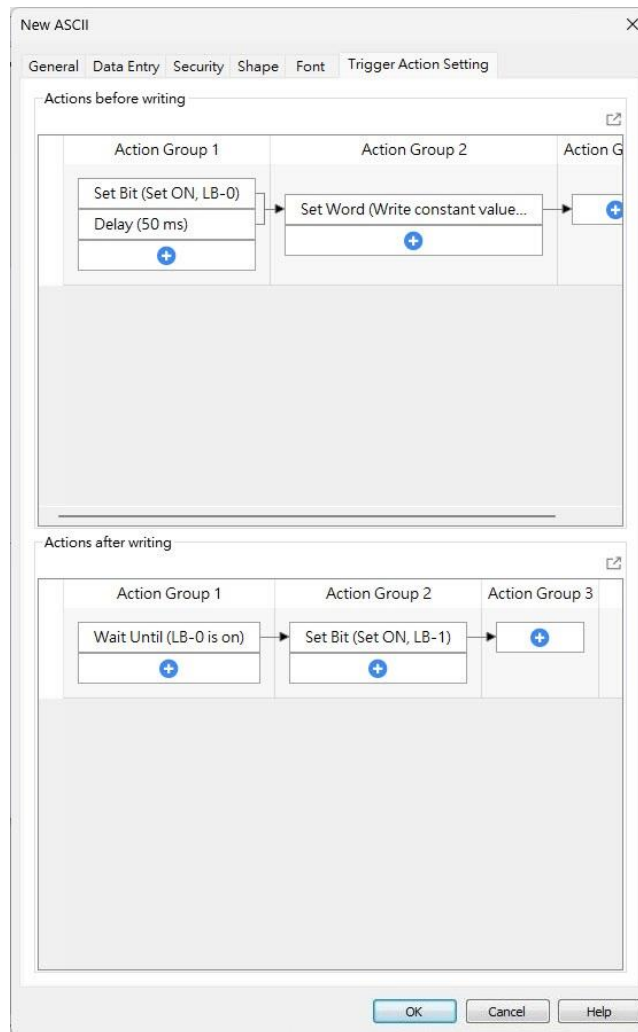

Setting	Description
Actions	The predefined action groups will be executed once the write

before writing	operation starts, and will not wait for it to be completed.
Actions after writing	The predefined action groups will be executed when the write operation is completed.

13.11. Indirect Window

13.11.1. Overview

Indirect Window object opens or closes a pop-up window assigned by a designated word register. There are two ways to use Indirect Window object: The first is to use the profile of Indirect Window object, and let the pop-up window be resized and displayed in the defined profile; the second is to automatically resize the window according to the size of the pop-up window to be displayed. To close the pop-up window, assign 0 to the designated word register. The difference between Direct Window and Indirect Window is that Direct Window is controlled by a bit register, while Indirect Window is controlled by a word register.

13.11.2. Configuration



Click [Object] » [Embed Window] » [Indirect Window] icon on the toolbar to open the object property dialog box. Set up the properties, press OK button, and a new Indirect Window object will be created.

General Tab

cMT / cMT X Series

eMT, iE, XE, mTV Series

Setting	Description
Style	<p>This setting is available only on cMT / cMT X Series. When a base window contains an underlay window, this setting determines the display style of an Indirect Window placed in the underlay window. Please see Example 2 below.</p> <p>Embedded in parent window</p> <p>The Indirect Window is displayed in its parent window. When an Indirect Window is placed in an underlay window, the Indirect Window is displayed in the underlay window when it is called in the base window.</p> <p>Popup window</p> <p>The Indirect Window is displayed in the base window. When an Indirect Window is placed in an underlay window, the Indirect Window is displayed in the base window when it is called in the base window.</p> <p>Title Bar Setting</p> <p>When [Enable title bar] is selected, a field shows for entering the caption in the title bar. The caption can be selected from Label Tag Library.</p>

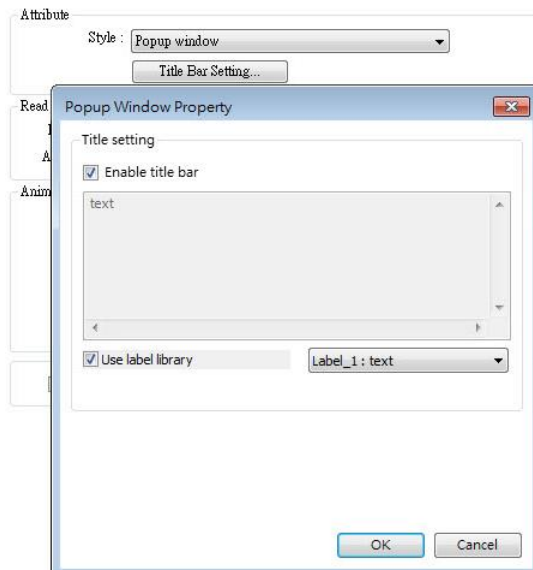

Read address	Click [Setting] to select the [PLC name], [Address], [Device type], [System tag], [Index register] of the word device that controls the pop-up window. Users can also set address in [General] tab while adding a new object.
Attribute	<p>Style</p> <p>Set the display style of the pop-up window. There are two styles:</p> <ul style="list-style-type: none"> ● No title bar

The pop-up window has no title bar and cannot be dragged.



- With title bar

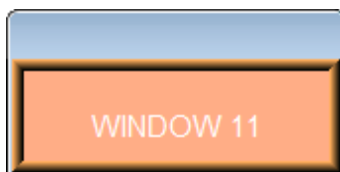

The pop-up window has a title bar that can be dragged to move the window.



Animation
(cMT / cMT X Series)

Effect
Different effects may be used for Start (window appears) and End (window disappears).

Effect Name	Transition
Fade	
Fly	
Float	
Wipe	
Split	
Circle	

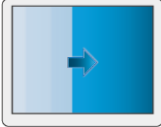
Clock	
Zoom	
Turn	
Push	

Duration

Specifies how many milliseconds (ms) a transition effect takes to complete.

Direction

The direction of the transition.

**Use window
no. offset**

Sets the offset of the window number for selecting the pop-up window. The window number of the pop-up window is calculated by the value in the word register added to the offset. For example, assume the value in the register is 20 and offset is 5, the pop-up window number will be 25.

Position

cMT / cMT X Series

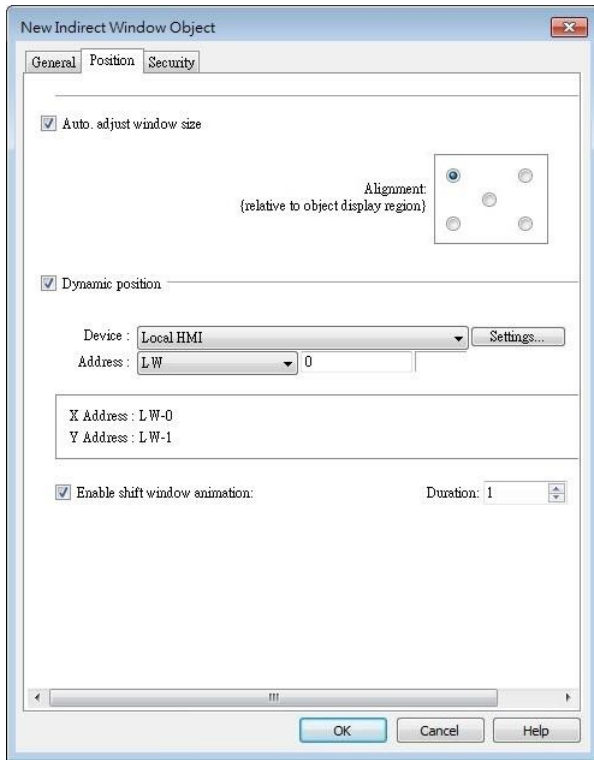

eMT, iE, XE, mTV Series

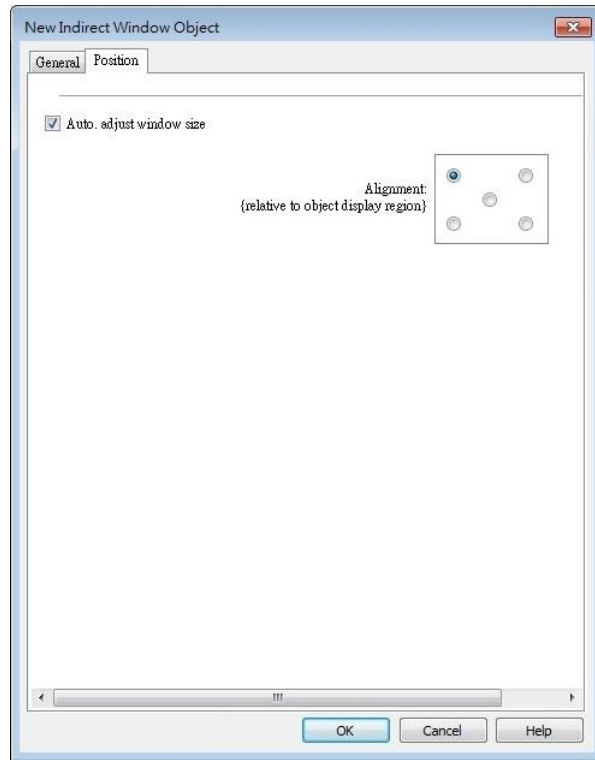

Setting	Description
Auto. adjust window size	Automatically resizes the Indirect Window and align the pop-up window to the preset region.
Alignment	Sets a reference point of the pop-up window from one of the five positions on the screen; for example, if the lower-right region is selected, the lower-right corner of the pop-up window is aligned to the lower-right region of the Indirect Window. See Example 1.
Dynamic position	With this option selected, the position of the window on the screen can be changed dynamically by the values in the designated address.
Enable shift window animation	With this option selected, the window changes position with transition effect.

Example 1

Here is an example of using Indirect Window. The setting is shown in the following figure, set the address to LW-0 which assigns the window number. Create window no. 11 and 12 first.

1. Create an Indirect Window object, set address to LW-0, and select [Auto. adjust window

size].

2. Select the region where the window is to be displayed.

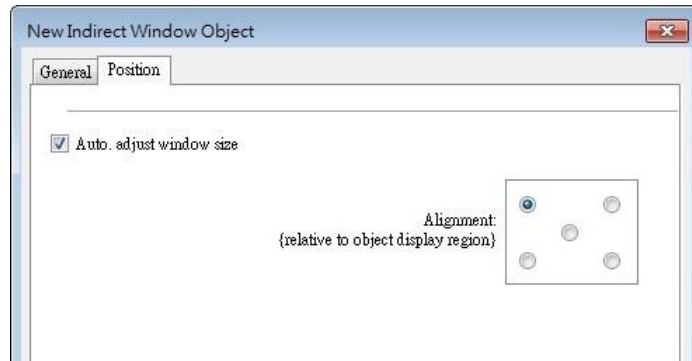

3. Enter value 11 in LW-0, the pop-up window displayed is window no. 11.
4. Enter value 12 in LW-0, the pop-up window displayed is window no. 12.
5. Enter value 0 in LW-0, the pop-up window is closed.

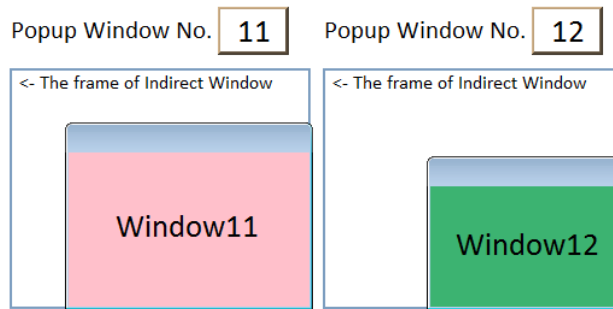

To close the pop-up window, apart from entering 0 in the designated word register, another way is to place a Function Key object in the pop-up window, and set the key to [Close window].

Example 2

Here is an example showing the difference between these two styles: [Embedded in parent window] and [Popup window]. The style setting determines how an Indirect Window placed in an underlay window is displayed when it is called in the base window.

1. Add two base windows: Window no. 10 and Window no. 11. Add an underlay window in Window no. 10 and set Window no. 11 as the underlay window.

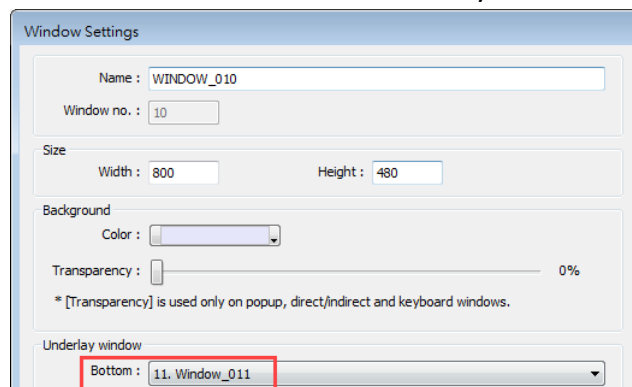

2. Create several objects in Window no. 10.

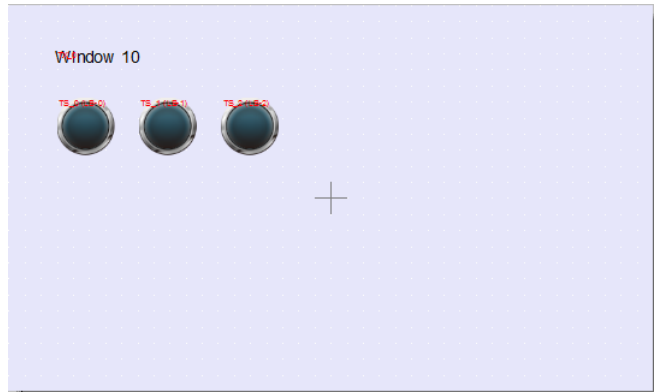

- In Window no. 11 create an Indirect Window object and a Numeric Input object. Set both read addresses to LW-0.

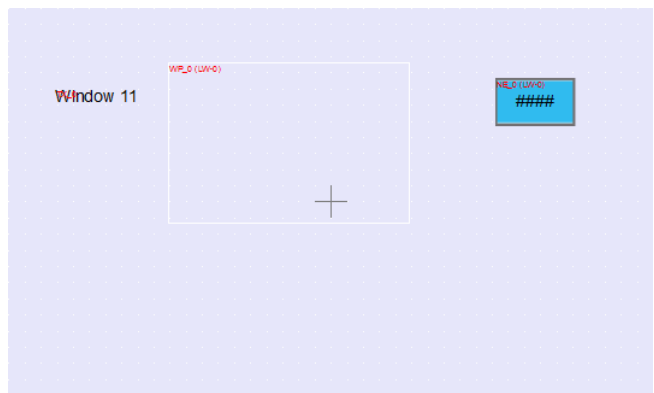

- By entering a window number in the Numeric Input object, the Indirect Window is displayed according to the selected style.

Embedded in parent window

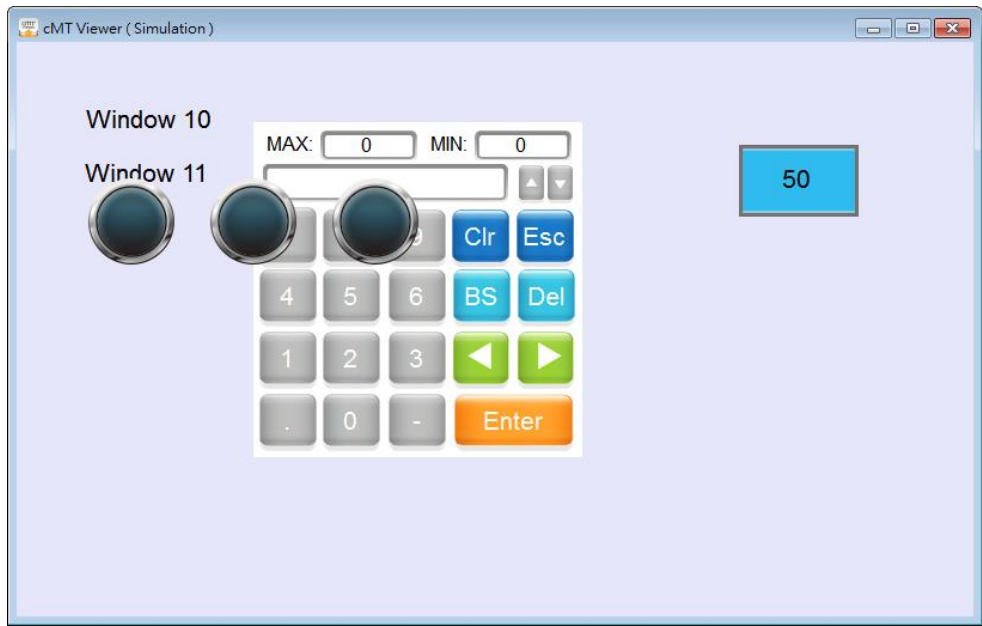

Popup window



Note

- For eMT/iE/XE/mTV models, a screen can display up to 24 pop-up windows simultaneous including System Message Window, Direct Window and Indirect Window. For cMT / cMT X Series, the number of pop-up windows is not limited.
- The system does not allow opening the same window with two Direct (or Indirect) windows in one base window.
- If the pop up window has monopoly property enabled, then when the window pops up, all background windows may not be operated until the monopolizing window has been closed.

13.12. Direct Window

13.12.1. Overview

Direct Window object opens or closes a pop-up window assigned by a designated bit register. When the state of the bit register changes, the pop-up window appears at the predefined location. The display area for the pop-up window is limited by the size of predefined location. Returning the state of the bit register closes the pop-up window. The difference between Direct Window and Indirect Window is that Direct Window is controlled by a bit register, while Indirect Window is controlled by a word register.

13.12.2. Configuration



Click [Object] » [Embed Window] » [Direct Window] icon on the toolbar to open a Direct Window object property dialog box. Set up the properties, press OK button, and a new Direct Window object will be created.

General Tab

cMT / cMT X Series

eMT, iE, XE, mTV Series

Setting	Description
Style	<p>This setting is available only on cMT / cMT X Series. When a base window contains an underlay window, this setting determines the display style of a Direct Window placed in the underlay window. Please see Example 2 in Chapter13.11 in this manual.</p> <p>Embedded in parent window</p> <p>The Direct Window is displayed in its parent window. When a Direct Window is placed in an underlay window, the Direct Window is displayed in the underlay window when it is called in the base window.</p> <p>Popup window</p> <p>The Direct Window is displayed in the base window. When a Direct Window is placed in an underlay window, the Direct Window is displayed in the base window when it is called in the base window.</p> <p>Title Bar Setting</p> <p>When [Enable title bar] is selected, a field shows for entering the caption in the title bar. The caption can be selected from Label Tag Library.</p>
Read address	<p>Click [Setting] to select the [PLC name], [Address], [Device type], [System tag], [Index register] of the bit device that controls the pop-up window. Users can also set address in [General] tab while adding a new object.</p>
Attribute	<p>Style</p> <p>Set the display style of the pop-up window. There are two styles:</p> <ul style="list-style-type: none"> ● No title bar <p>The pop-up window has no title bar and cannot be dragged.</p>

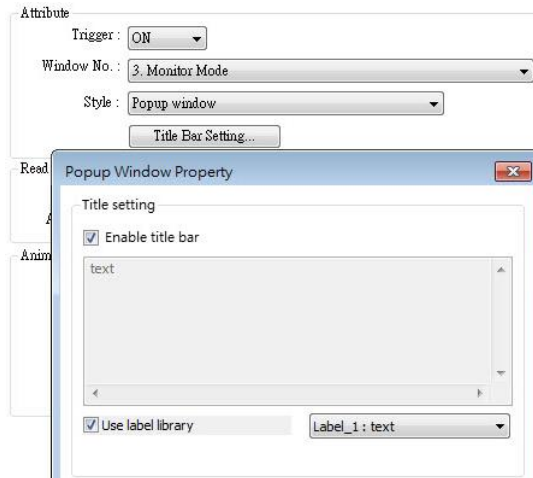



- With title bar

The pop-up window has a title bar that can be dragged to move the window.

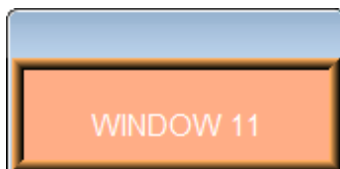

Window no.



Set the pop-up window number.

**Animation
(cMT / cMT X
Series)**

Effect

Different effects may be used for Start (window appears) and End (window disappears).

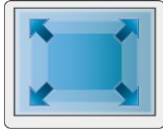
Effect Name	Transition
Fade	
Fly	
Float	
Wipe	
Split	
Circle	

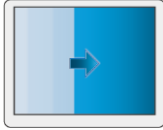
Clock	
Zoom	
Turn	
Push	

Duration

Specifies how many milliseconds (ms) a transition effect takes to complete.

Direction

The direction of the transition.

Position

cMT / cMT X Series

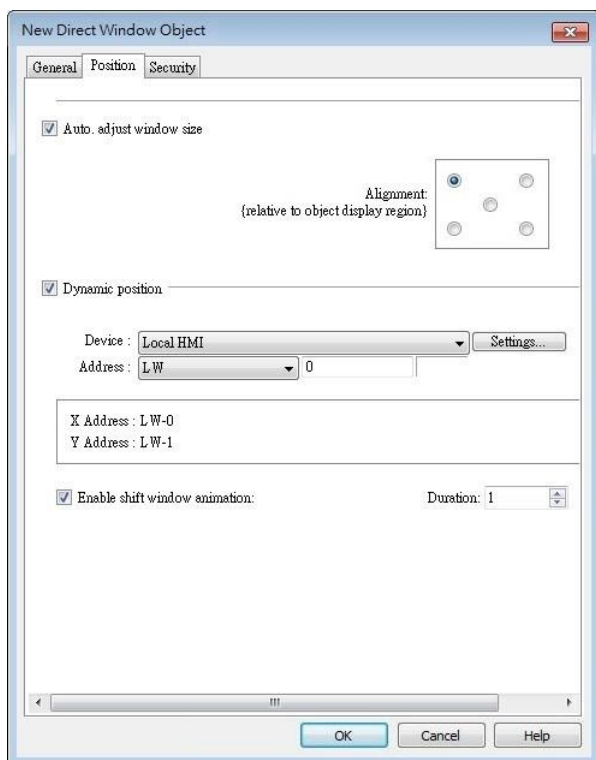

eMT, iE, XE, mTV Series

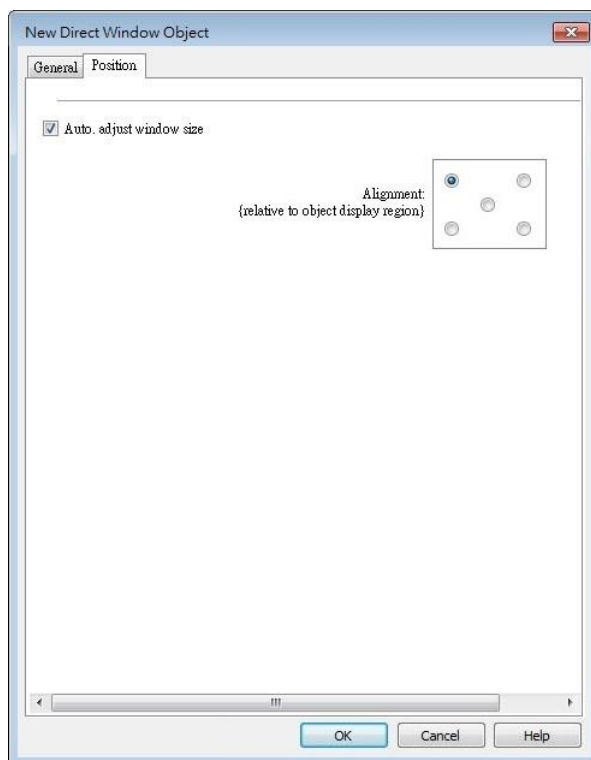

Setting	Description
Auto. adjust window size	Automatically resizes the Direct Window and align the pop-up window to the preset region. Alignment Sets a reference point of the pop-up window from one of the five positions on the screen; for example, if the lower-right region is selected, the lower-right corner of the pop-up window is aligned to the lower-right region of the Direct Window. See Example 1.
Dynamic position	With this option selected, the position of the window on the screen can be changed dynamically by the values in the designated address. Enable shift window animation With this option selected, the window changes position with transition effect.

Example 1

Create window no. 11 which can be controlled by a Toggle Switch with address LB-0.

1. Create a Direct Window object and set read address to LB-0.
2. In this example, the reference point for alignment is set to the lower-right region.

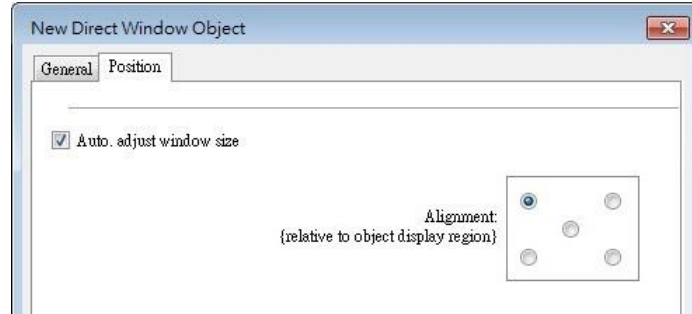

3. When LB-0's state is ON, window no. 11 will show.



4. When LB-0's state is OFF, window no. 11 will be hidden.

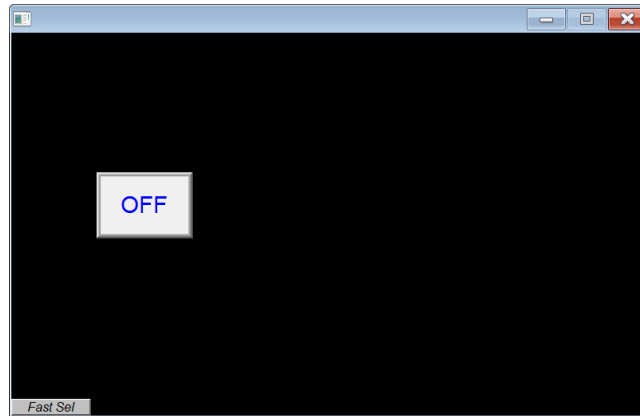

Note

- For eMT/iE/XE/mTV models, a screen can display up to 24 pop-up windows simultaneous including System Message Window, Direct Window and Indirect Window. For cMT / cMT X Series, the number of pop-up windows is not limited.
- The system does not allow opening the same window with two Direct (or Indirect) Windows in one base window.
- If the pop up window has monopoly property enabled, then when the window pops up, all background windows may not be operated until the monopolizing window has been closed.

13.13. Moving / Rotating Shape

13.13.1. Overview

Moving / Rotating Shape is an object that changes its state, moves, and/or rotates according to the user-defined parameters. The state, moving distance, and rotation direction/angle are determined by values in consecutive registers.

13.13.2. Configuration



Click [Object] » [Animation] » [Moving / Rotating Shape] icon on the toolbar to create the object, set up the properties, press OK button, and a new Moving / Rotating Shape object will be created.

General Tab

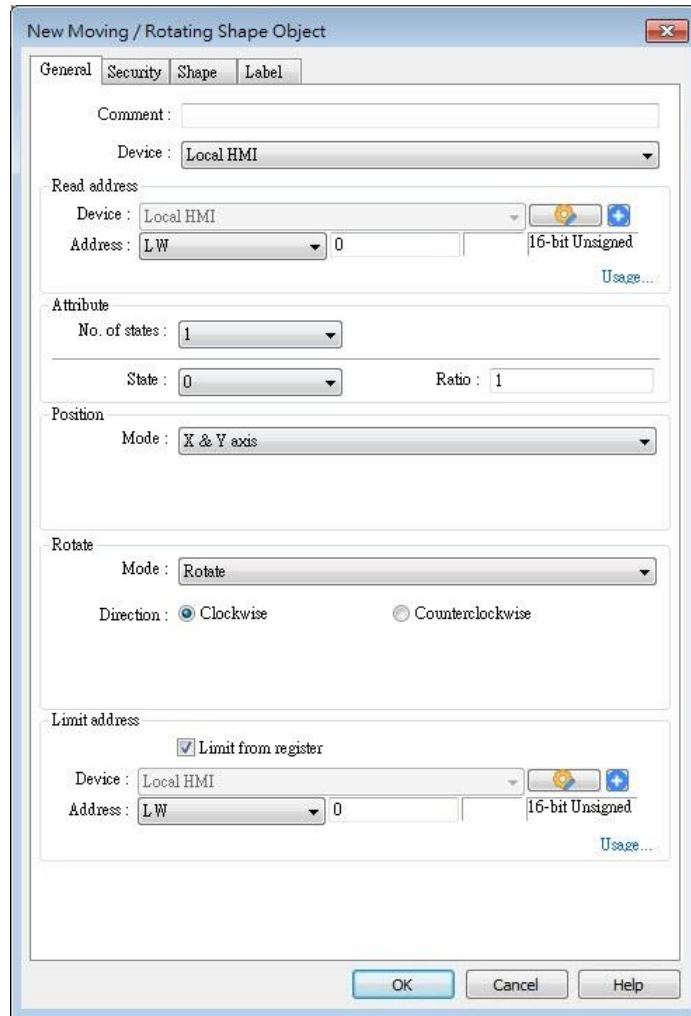

Setting	Description
Read address	Click [Setting] to configure the [Device], [Device type], [Address], [System tag], or [Index register] of the word devices that control the display of object's state and moving distance. Users can also set the address in [General] tab while adding a new object.
Attribute	Select the object's movement mode and range. See "13.13.2.1 Illustration of Modes" in the following part.
Display ratio	The size of shape in different states can be set individually as shown in the following figure. <div style="display: flex; justify-content: space-around; align-items: center; margin-top: 10px;"> <div style="text-align: center;"><i>Ratio : 1</i> State 0</div> <div style="text-align: center;"><i>Ratio : 1.2</i> State 1</div> <div style="text-align: center;"><i>Ratio : 1.4</i> State 2</div> <div style="text-align: center;"><i>Ratio : 1.6</i> State 3</div> </div>
Rotate	Select Clockwise or Counterclockwise for Direction and define the

angle range (unit in degree) within which the object may rotate. The allowable range is 0~360 degrees, and the Max. angle should be greater than Min. angle.

For more information please see “13.13.2.2 Rotation Modes”.

Limit address The object’s moving range can be set by adjusting the data in the designated register, see Example 1.

Example 1

Supposed that the object’s moving range is limited by register LW-n, the addresses in the following table are used to limit the moving / rotating range.

Data format	16-bit	32-bit	64-bit (cMT / cMT X only)
Position - [Min. X] address	LW-n	LW-n	LW-n
Position - [Max. X] address	LW-n+1	LW-n+2	LW-n+4
Position - [Min. Y] address	LW-n+2	LW-n+4	LW-n+8
Position - [Max. Y] address	LW-n+3	LW-n+6	LW-n+12
Rotate – Input Low	LW-n+4	LW-n+8	LW-n+16
Rotate – Input High	LW-n+5	LW-n+10	LW-n+20
Rotate – Scaling Low	LW-n+6	LW-n+12	LW-n+24
Rotate – Scaling High	LW-n+7	LW-n+14	LW-n+28

13.13.2.1. Illustration of Modes

Available modes are: (Assume Read Address is LW-n)

- X axis only

The object is only allowed to move along the X-axis. The moving distance ranges from [Min. X] to [Max. X].

Attribute

Mode :

No. of states :

Min. X : Max. X :

Data format	16-bit	32-bit	64-bit (cMT / cMT X only)
Object state	LW-n	LW-n	LW-n
Moving distance on X-axis	LW-n+1	LW-n+2	LW-n+4

- Y axis only

The object is only allowed to move along the Y-axis. The moving distance ranges from [Min. Y] to [Max. Y].

Attribute

Mode : Y axis only

No. of states : 8

Min. Y : 0 Max. Y : 480

Data format	16-bit	32-bit	64-bit (cMT / cMT X only)
Object state	LW-n	LW-n	LW-n
Moving distance on Y-axis	LW-n+1	LW-n+2	LW-n+4

- X & Y axis

The object is allowed to move along the X-axis and Y-axis. The moving range in X and Y directions is defined by [Min. X], [Max. X] and [Min. Y], [Max. Y] respectively.

Attribute

Mode : X & Y axis

No. of states : 8

Min. X : 0 Max. X : 600

Min. Y : 0 Max. Y : 480

Data format	16-bit	32-bit	64-bit (cMT / cMT X only)
Object state	LW-n	LW-n	LW-n
Moving distance on X-axis	LW-n+1	LW-n+2	LW-n+4
Moving distance on Y-axis	LW-n+2	LW-n+4	LW-n+8

For example, if the object's read address is LW-100 and the data format is [16-bit Unsigned], LW-100 is used to control the object's state, LW-101 is used to control the object's moving distance on the X-axis, and LW-102 is used to control the object's moving distance on the Y-axis. The following figure shows that the object's read address is LW-100 and initial position is (100, 50). To move the object to the position (160,180) and change its state to State 2, assign 2 to LW-100, $160-100 = 60$ to LW-101, $180-50 = 130$ to [LW102].

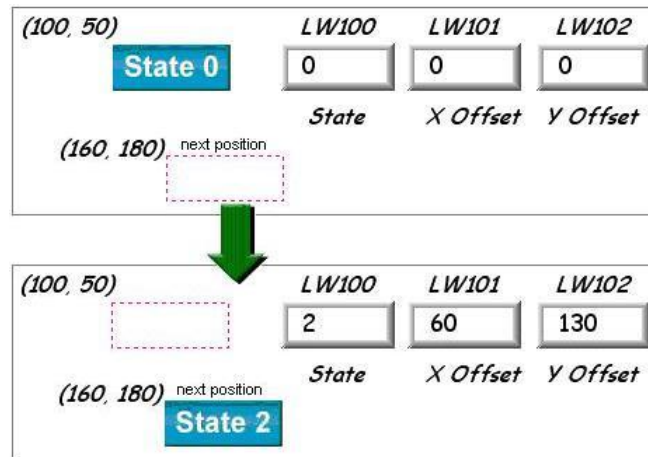

- X axis w/ scaling

The object moves in X-axis only with scaling. Suppose that the value of the designated register is DATA, the system uses the following equation to calculate the moving distance on the X-axis.

$$\text{Displacement} = (\text{Data} - [\text{Input low}]) \times \frac{[\text{Scaling high}] - [\text{Scaling low}]}{[\text{Input high}] - [\text{Input low}]}$$

Data format	16-bit	32-bit	64-bit (cMT / cMT X only)
Object state	LW-n	LW-n	LW-n
Moving distance on X-axis	LW-n+1	LW-n+2	LW-n+4

- Y axis w/ scaling

The object is for Y axis movement with scale, and the equation to calculate the moving distance on the Y-axis is the same as the one in [X axis w/ scaling].

Data format	16-bit	32-bit	64-bit (cMT / cMT X only)
Object state	LW-n	LW-n	LW-n
Moving distance on Y-axis	LW-n+1	LW-n+2	LW-n+4

- X axis w/ reverse scaling

This works in the way as [X axis w/ scaling], but the moving direction is in reverse.

- Y axis w/ reverse scaling

This works in the way as [Y axis w/ scaling], but the moving direction is in reverse.

13.13.2.2. Rotation Modes

The addresses that control the moving / rotating shape are consecutive addresses starting from Read Address (LW-n), and they may vary depending on the selected mode. Please click [Usage...] to open the window that shows the control addresses relating to rotation parameters.

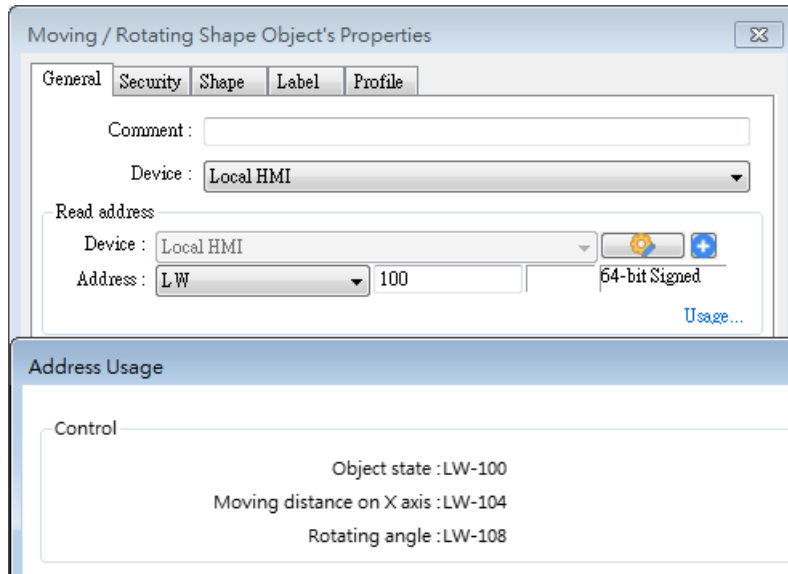

- Rotate

Select rotating direction from clockwise or counterclockwise and set the Min. and Max. angle range.

When rotation animation is enabled, two modes can be selected: Default and Shortest.

e.g. When the angle measure is set to clockwise and the rotating angle is changed from 10 degrees to 350 degrees, these two modes give different results:

Default: rotates 340 degrees clockwise (linear interpolation between the two numbers)

Shortest: rotates 20 degrees counterclockwise (in the direction that produces the shortest animation path)

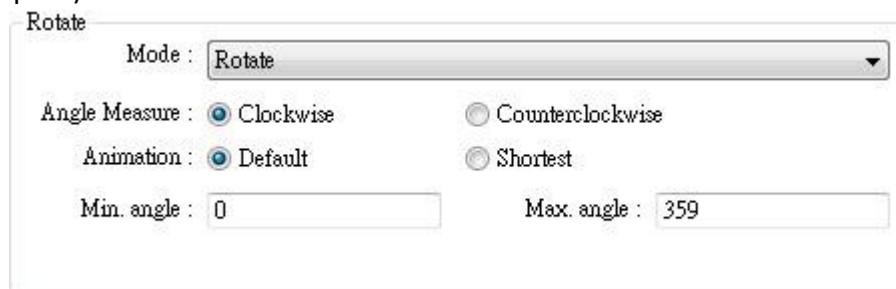

- Rotate w/ scaling

Select rotating direction from clockwise or counterclockwise. The angle of rotation is calculated by the formula as shown below.

$$\text{Angle of Rotation} = (\text{Data} - [\text{Input low}]) \times \frac{[\text{Scaling high}] - [\text{Scaling low}]}{[\text{Input high}] - [\text{Input low}]}$$

- Rotate w/ reverse scaling

Similar to [Rotate w/ scaling] but reverses the object from clockwise to counterclockwise and vice versa.

13.14. Animation

13.14.1. Overview

Animation object is defined by a pre-defined point set and states. Animation object will then move to a given point in a given state defined by designated registers. The object state and position depend on current value of two consecutive registers. The first register controls the state of the object and the second register controls the position along the predefined path.

13.14.2. Configuration



Click [Object] » [Animation] » [Animation] icon on the toolbar. First, create the pre-defined path. Move the mouse to each moving position, and click the left button to define positions one by one. When it is done, right click on the screen, set up the properties, press OK button, and a new Animation object will be created.



To change the object's attributes, double click on the object to open Animation Object's Properties dialog box.

General Tab

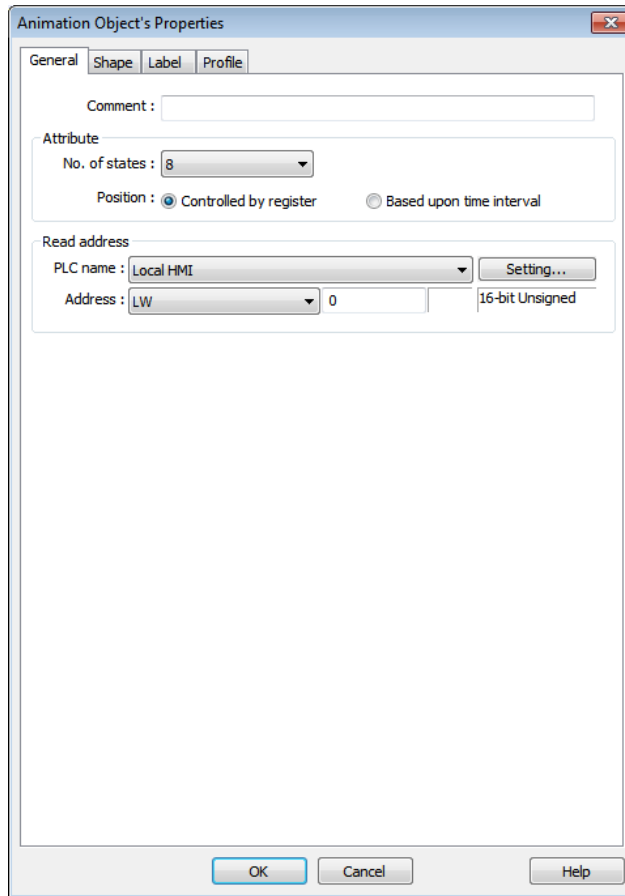

Setting	Description
Attribute	<p>No. of states Configure the number of states for this object.</p> <p>Controlled by register Use the designated registers to control the object’s state and position. See Example 1.</p> <p>Based upon time interval The object’s state and position will change from time to time. [Time interval attributes] is used to set the time interval for states and positions.</p>
	
	<p>Position speed: The speed of movement. The unit is 0.1 second. Supposed that [Speed] is set to 10, the object’s position will change each second.</p>

Image state change: Determines how state changes, either [Position dependent] or [Time-based]. If [Position dependent] is selected, the object state will change when position changes. If [Time-based] is selected, the object position will change based on [Position speed] and the object state will change based on [Image update time].

Backward cycle: Assumed the object has four positions: position 0, position 1, position 2, and position 3, and [Backward cycle] is not selected. When the object moves to the last position (position 3), the next position will be back to the initial position 0, and repeat. The moving path is shown as follows:

position 0 → position 1 → position 2 → position 3 → position 0 → position 1 → position 2...

If [Backward cycle] is selected, when the object moves to the last position (position 3), it will move backwards to position 2, position 1 and then the initial position 0, and start over again. The moving path is shown as follows.

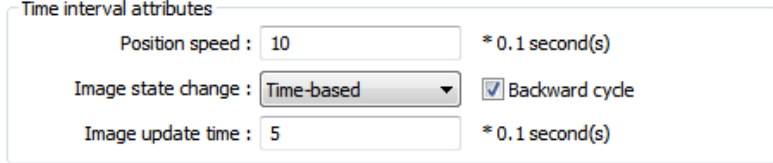
position 0 → position 1 → position 2 → position 3 → position 2 → position 1 → position 0...

Example 1

The object's state and position are determined by the registers, and the addresses must be configured correctly, as in the following table:

Data format	16-bit	32-bit	64-bit (cMT / cMT X only)
Object state	LW-n	LW-n	LW-n
Object position	LW-n+1	LW-n+2	LW-n+4

For example, if the designated register is LW-100 and the data format is [16-bit Unsigned], then LW-100 represents object's state, LW-101 represents position. In the picture below, LW-100 = 2, LW-101 = 3, so the object's state is 2 and position is 3.

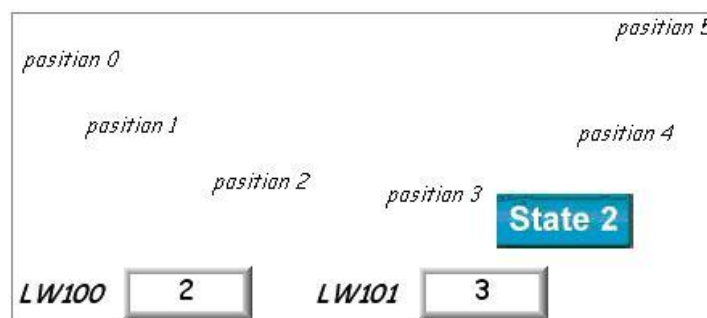

Profile Tab

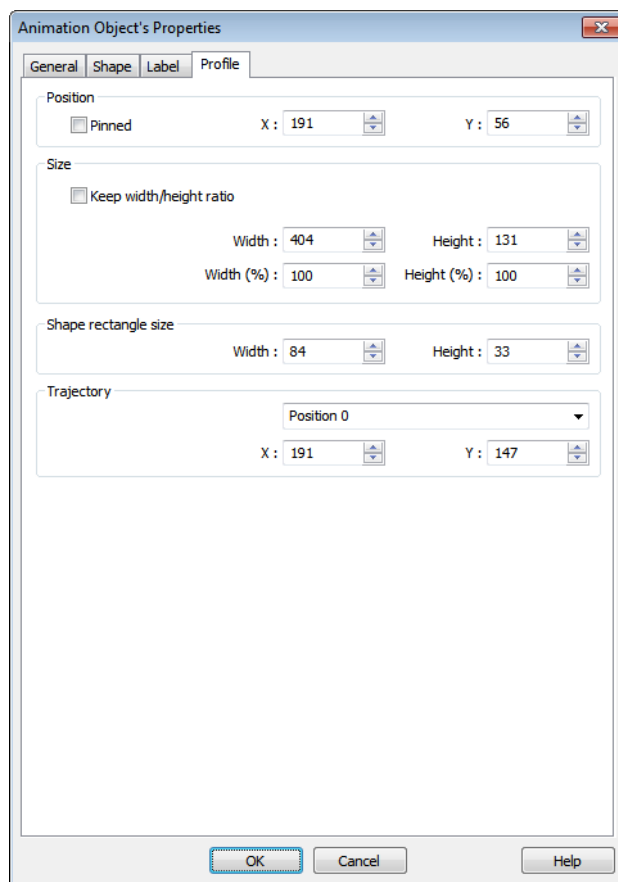

Setting	Description
Shape rectangle size	Set the size of the shape.
Trajectory	Set the position of each point on the moving path.

Note

- Since multiple pictures might be used by an [Animation] object, [Set to original dimension] will not return all pictures to the original size.

13.15. Bar Graph

13.15.1. Overview

Bar Graph object displays data as a bar graph for visualization.

13.15.2. Configuration



Click [Object] » [Chart] » [Bar Graph] icon on the toolbar to open Bar Graph dialog box. Select properties, click OK button, a new Bar Graph object is created.

General Tab

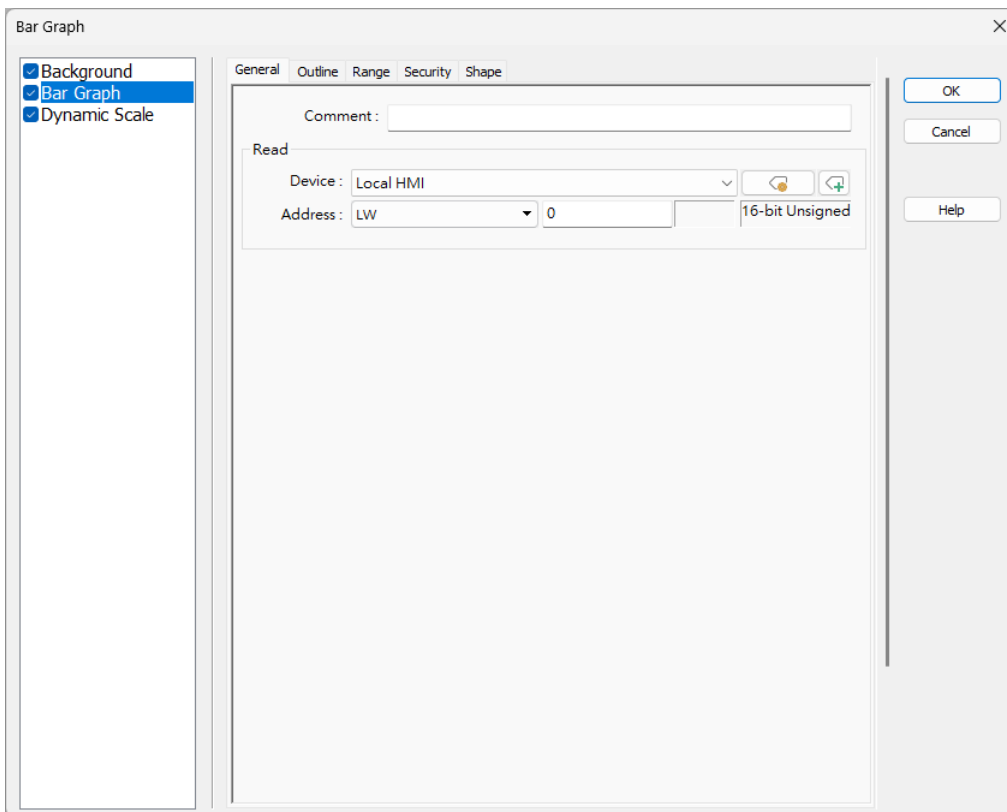

Setting	Description
Read address	Click [Setting] to Select the [Device], [Device type], [Address], [System tag], and [Index register] of the word devices that controls how the bar graph displays.

Outline Tab

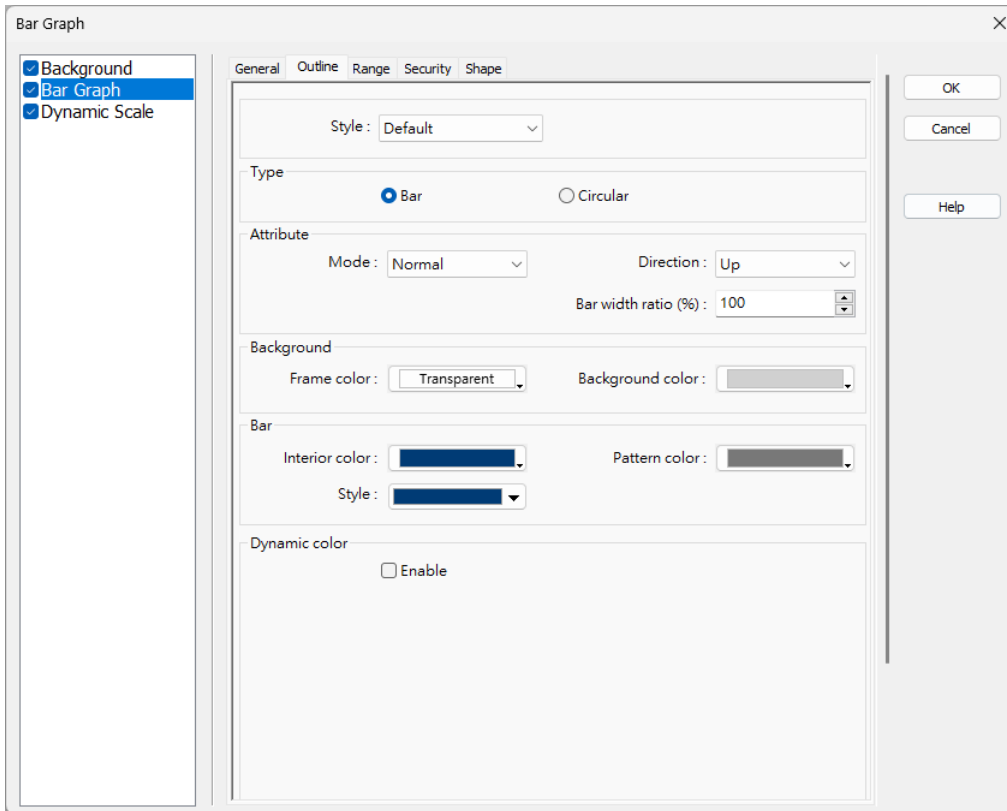

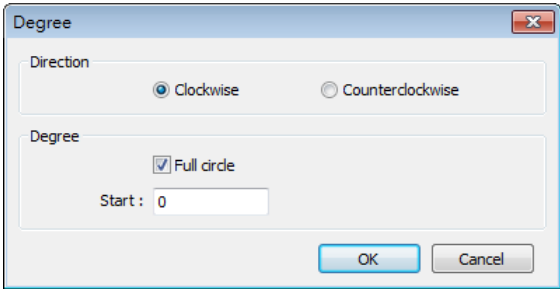
Setting	Description
Type	Choose either [Bar] or [Circular].
Attribute	<p>Mode Choose either [Normal] or [Offset]. If [Offset] is selected, an original value [Origin] must be entered for reference.</p> <p>Direction / Degree Bar: Determine the bar graph direction. Available options are [Up], [Down], [Right], and [Left]. Circular: Determine the circular bar graph direction. Available options are [Clockwise] and [Counter clockwise].</p>  <p>If [Full circle] is selected, set the start degree. If [Full circle] is not selected, set the start and end degree.</p> <p>Bar width ratio (%)</p>

The ratio of bar to object width. The figure below shows two ratios, 100% and 50%.

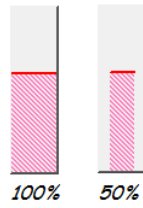

Hole Radius (%)

The ratio of the radius of the hole to the radius of the whole circular bar graph. The figure below shows two ratios, 0% and 50%.

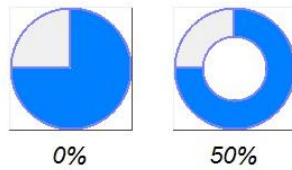

Color/Style

Set the bar's frame and background color, bar style, and bar color. See the picture below.

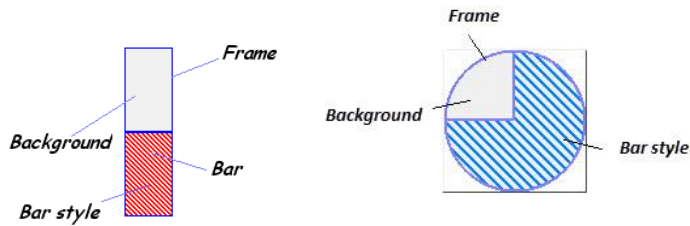

Dynamic color

(For cMT / cMT X Series models only) With this option selected, the interior color of the bar is determined by the value in the designated address.

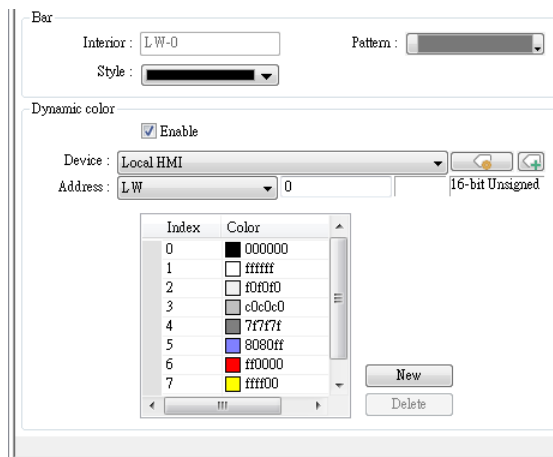

Range Tab

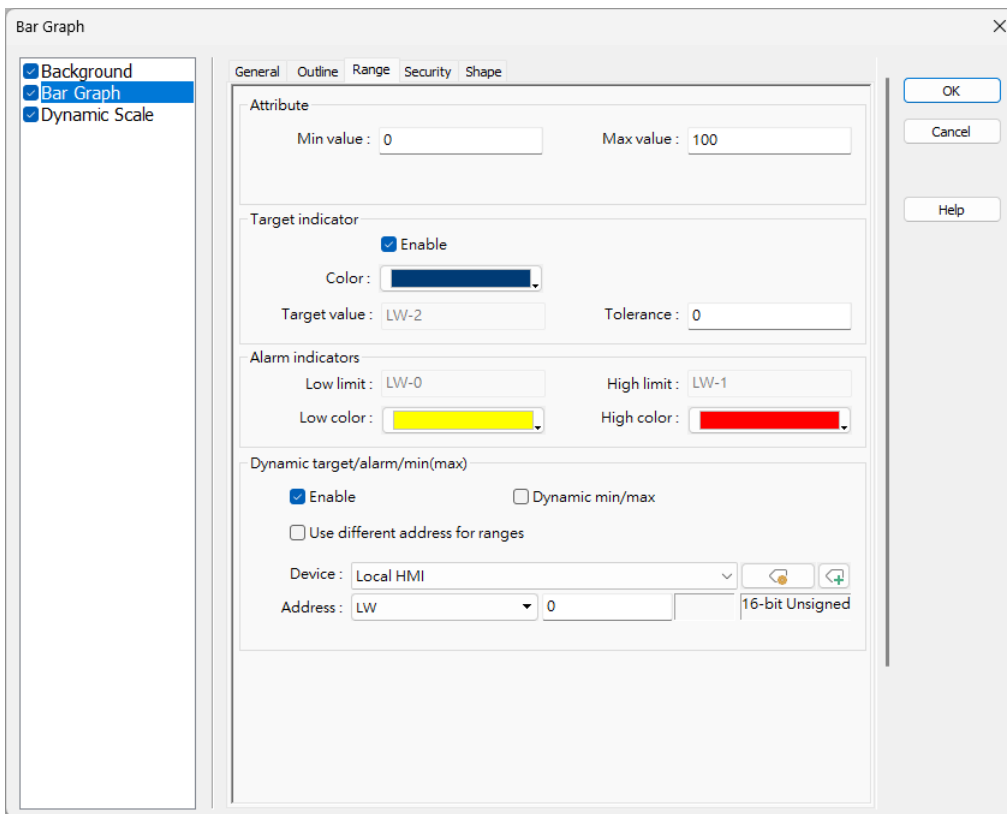

Setting	Description
Min value / Max value	The percentage of filling can be calculated by the formula, see Example 1.
Target indicator	When the register value meets the condition, the color of filled area will change to the target color, see Example 2.
Alarm indicators	If the register value is larger than [High limit], the color of filled area will change to [High color]. If the register value is smaller than [Low limit], the color will change to [Low color]. Please note that when [Dynamic color] is enabled, the Target indicator and Alarm indicator settings will not be present and their colors are determined by the designated addresses.
Dynamic target/alarm /min(max)	When enabled, the [Low limit] and [High limit] of [Alarm indicators] and the [Target Value] of [Target indicator] will use designated registers, which is shown in their respective fields, see Example 3. When [Dynamic min/max] is enabled, the [Min value] and [Max value] of [Attribute] will use designated registers, which is shown in their respective fields. When [Use different address for ranges] is enabled, the addresses mentioned above can be configured independently and read from

different registers. This option is only supported on cMT / cMT X.

Example 1

The percentage of filling in a Bar Graph can be calculated using the following formulas:

$$\text{Percentage of filling (Normal)} = \frac{\text{Register value} - [\text{Min. Value}]}{[\text{Max. Value}] - [\text{Min. Value}]} \times 100\%$$

$$\text{Percentage of filling (Offset)} = \frac{\text{Register value} - [\text{Origin}]}{[\text{Max. Value}] - [\text{Min. Value}]} \times 100\%$$

Assume [Offset] is selected. If (Register value – [Origin]) is greater than 0, the bar will fill upwards from the [Origin]. If (Register value – [Origin]) is less than 0, the bar will fill downwards from the [Origin].

The following diagrams demonstrate the filling behavior of the Bar Graph when the origin is set to 5, the max. value is 10, and the min. value is 0, using different data sets.

If the value at read address is 4:

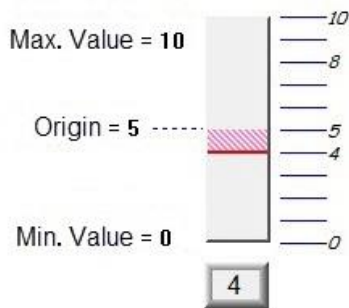

If the value at read address is 8:

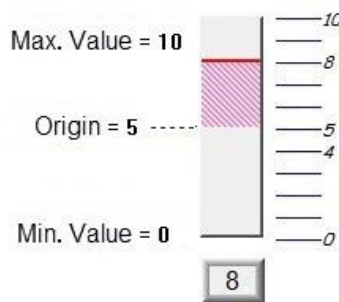

Example 2

When the register value meets the following condition, the color of filled area will change to the target color.

$$[\text{Target Value}] - [\text{Tolerance}] \leq \text{Register value} \leq [\text{Target Value}] + [\text{Tolerance}]$$

Assume [Target Value] is 5 and [Tolerance] is 1. As shown below, if the register value is equal to or larger than 4 (=5-1) and equal to or less than 6 (=5+1), the filled area's color of the bar will change to the target color.

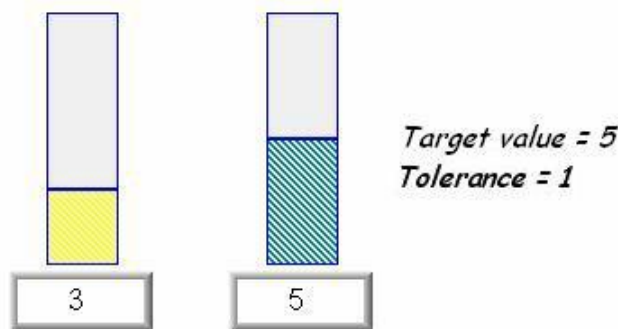

Example 3

The high and low limits for alarm indicators can be set by designated registers. When the write address is LW-n, the limits and related setting addresses will be automatically determined based on the following rules (assuming [Dynamic min/max] is enabled).

Data Format	16-bit	32-bit	64-bit (cMT / cMT X only)
Low Limit	LW-n	LW-n	LW-n
High Limit	LW-n+1	LW-n+2	LW-n+4
Target Value	LW-n+2	LW-n+4	LW-n+8
Min Value	LW-n+3	LW-n+6	LW-n+12
Max Value	LW-n+4	LW-n+8	LW-n+16
Origin	LW-n+5	LW-n+10	LW-n+20

13.15.3. Combo Setting

cMT / cMT X Series HMI support combo setting for Bar Graph, which allows setting of multiple related objects at a time. Bar Graph can be set with Background and Dynamic Scale.

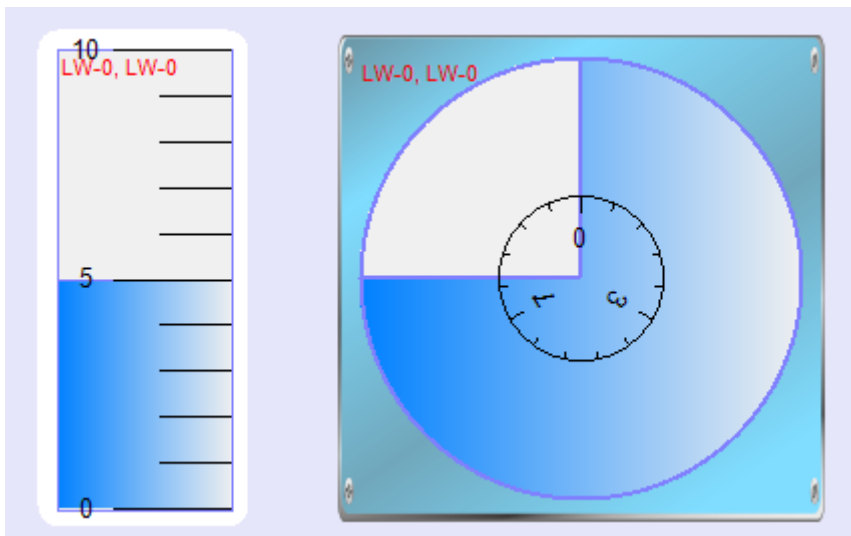

Background

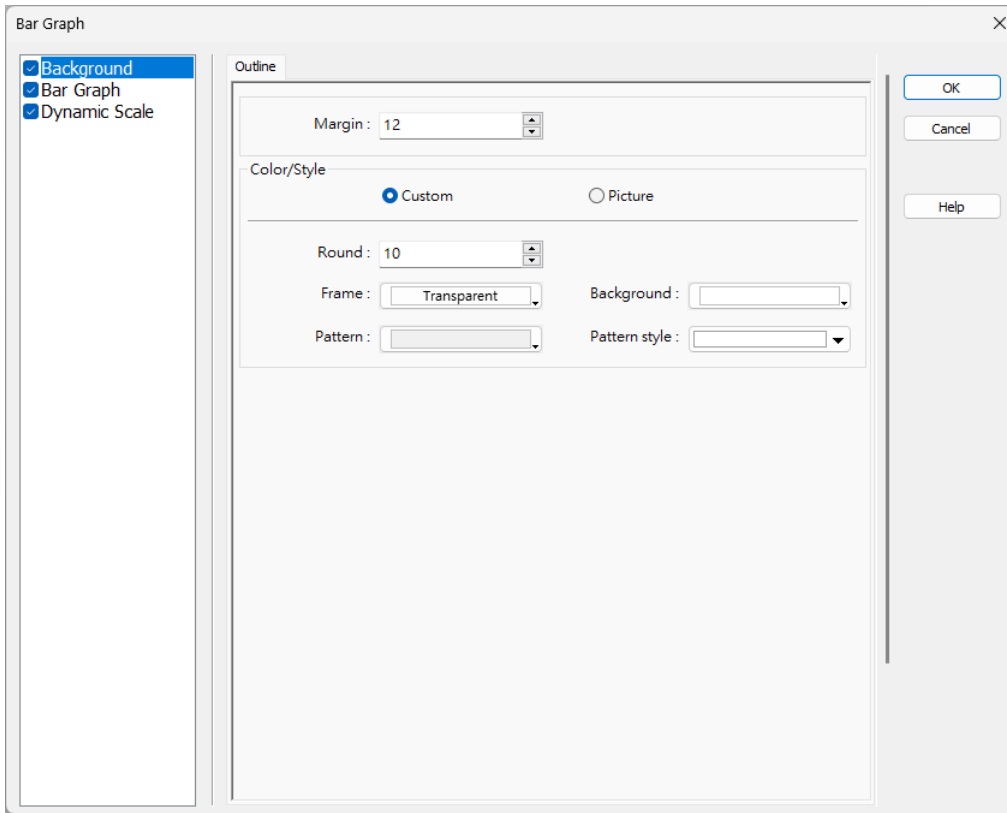

Setting	Description
Margin	Specify the space between the background edge and the objects.

Color/Style	Customize

Select a suitable background pattern and color.

Picture

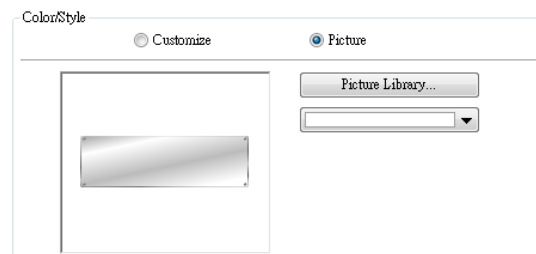

Use the default picture or choose a picture from Picture Library.

Dynamic Scale

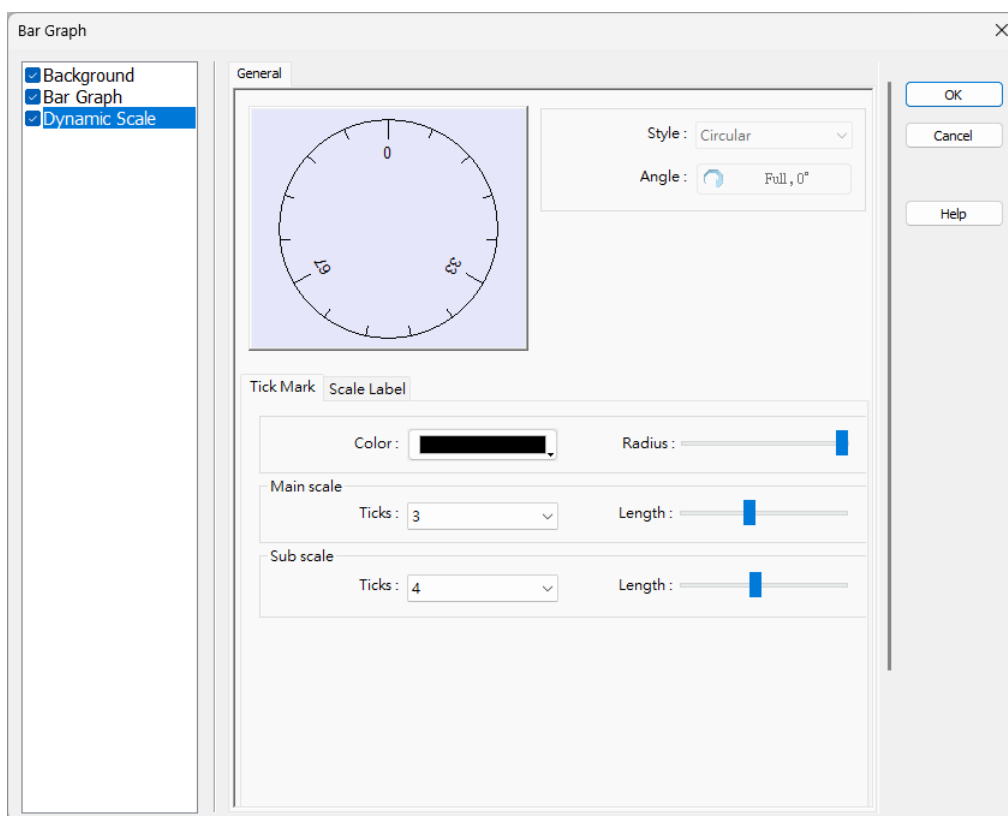

Setting	Description
Style	The scale style will follow the bar type.
Tick Mark	Configure the number of tick marks for main and sub scales. If the style is circular, the radius and tick mark length can be specified.
Scale Label	Configure the font, font color, font size and other attributes of scale label.

13.16. Meter Display

13.16.1. Overview

Meter Display object displays the value of word register with a meter.

13.16.2. Configuration



Click [Object] » [Chart] » [Meter Display] icon on the toolbar to open the Meter Display dialog box. Set the object's attributes and then click OK to create a new Meter Display object.

13.16.2.1. eMT, iE, XE, mTV Series

General Tab

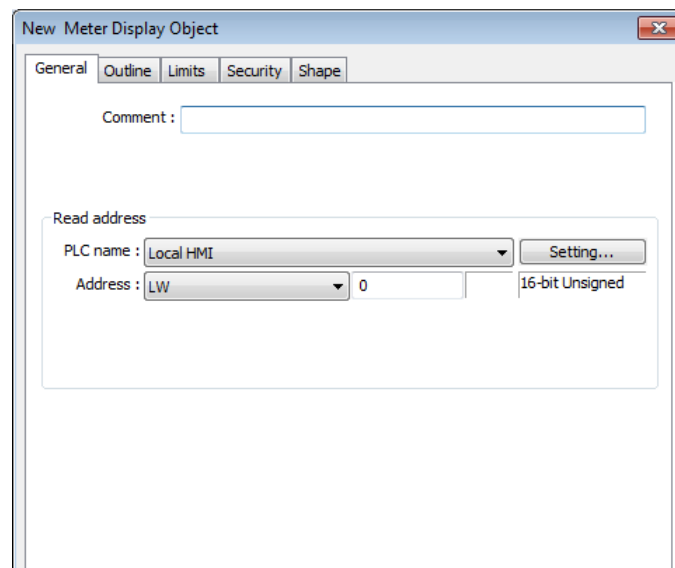

Setting	Description
Read address	Click [Setting] to select the [Device], [Device type], [Address], [System tag], and [Index register] of the word devices that controls the Meter Display object.

Outline Tab

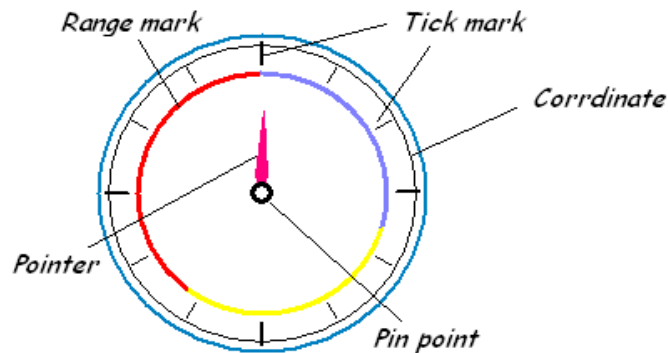
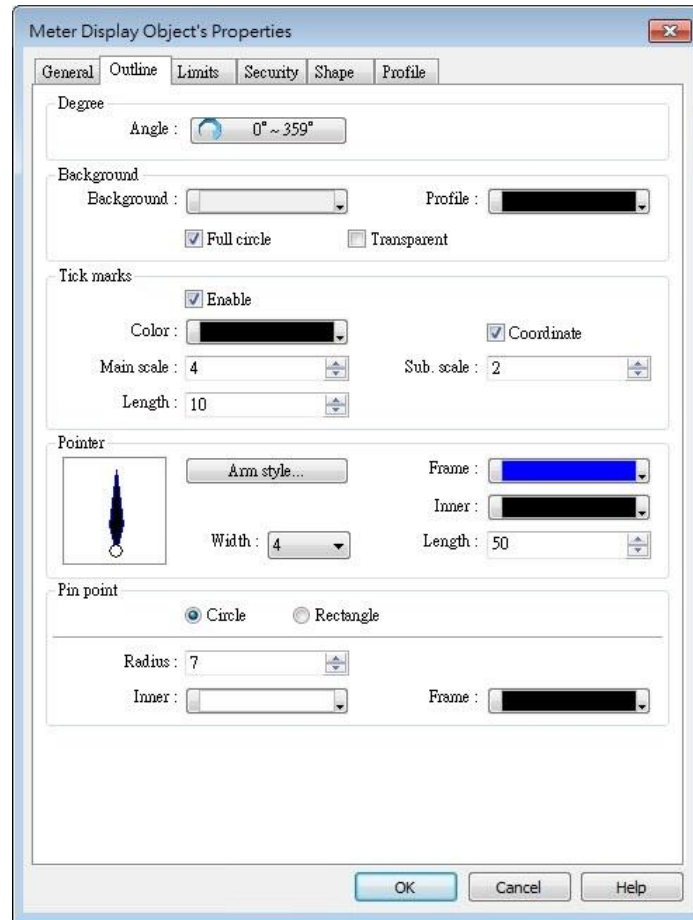

Setting	Description
Degree	Set the pointer to go around the meter clockwise or counterclockwise. Sets the object's start degree and end degree measured clockwise from the 12 o'clock position. The angle range is 0 to 360 degrees. The following shows meters of different settings.

- [Start degree] = 290°
[End degree] = 70°

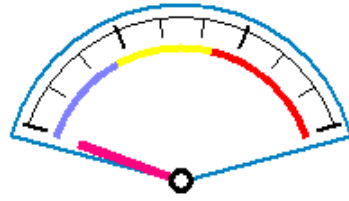

- [Start degree] = 120°
[End degree] = 240°

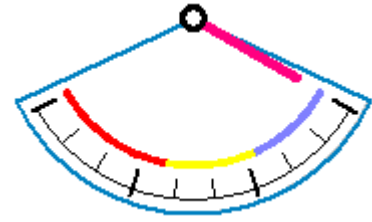

- [Start degree] = 40°
[End degree] = 140°

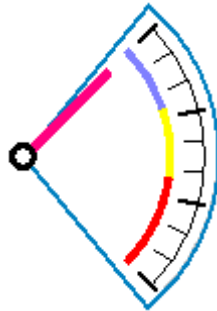

- [Start degree] = 225°
[End degree] = 315°

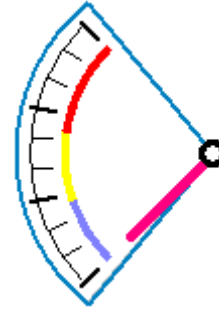

Background

Sets the object's background color and profile color.

Full circle

When selected, the object will display the whole circle. Otherwise, the object will only display a partial circle in the defined degree range, as shown in the following figure.

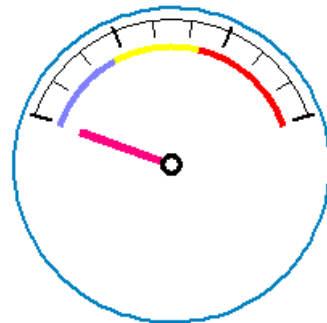

Full circle

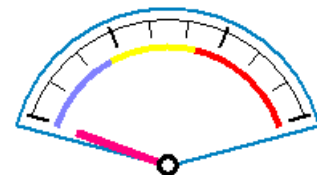

non-full circle

Transparent

When selected, the object will not display the background and profile color.

Tick marks

Configures the number of tick mark and color.

Pointer

Configures pointer's style, length, width, and color.

Pin point

Configures the style, radius, and color of the pin point.

Limits Tab

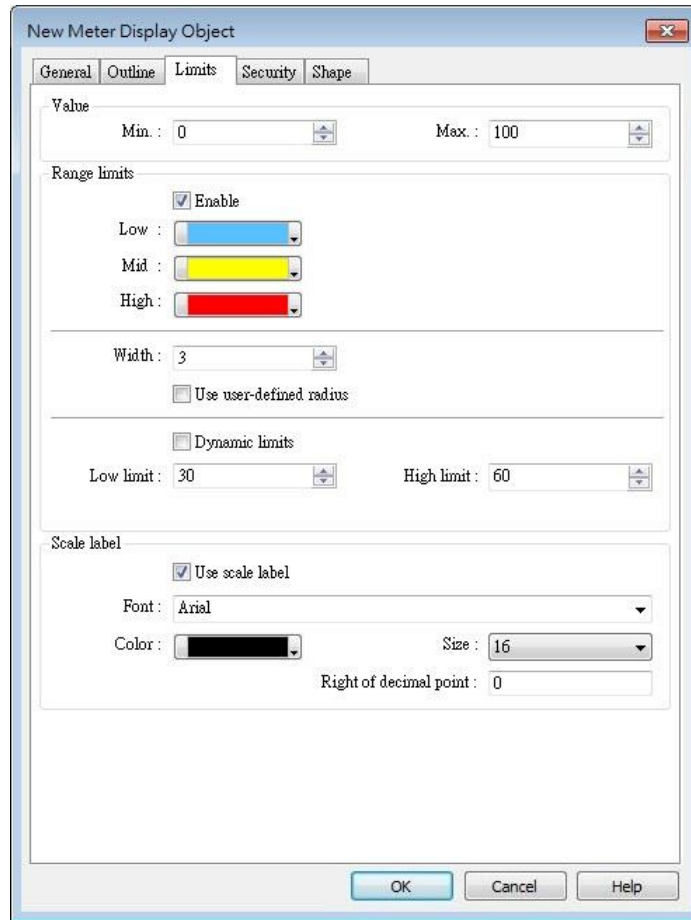

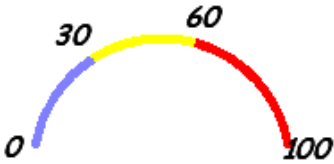
Setting	Description
Value	Sets the object's display range. Meter Display object will use the value of [Zero] and [Span] and the value of register to calculate the pointer's position. See Example 1.
Range limits	Configures the values of [Low limit], [High limit], their corresponding display colors, and the width. 
Use user-defined radius	Configures the radius to display range limits. For example, set to 80: Set to 30:

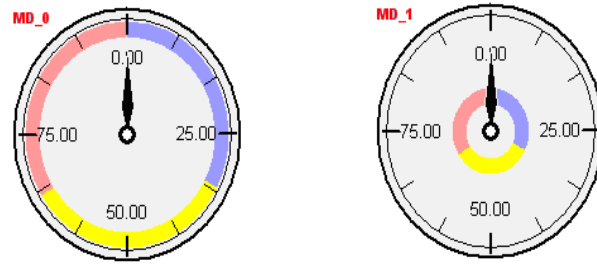

Dynamic Limits

The low limit and high limit are set by registers. See Example 2.

Scale label

Select the attribute of scale label on Meter Display.

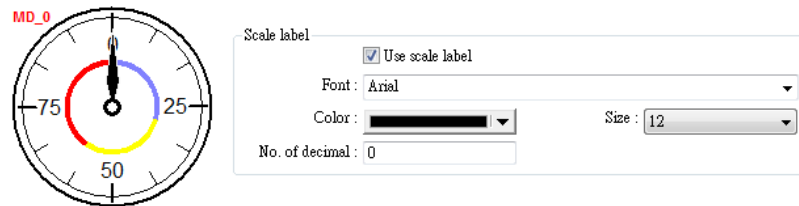

Example 1: Pointer position calculation

Set object’s display range. Meter Display object will use the value of [Zero] and [Span] and the value of register to calculate the pointer’s position. For example, supposed that [Zero] is 0, [Span] is 100, when the value of register is 30, [Start degree] is 0, and [End degree] is 360, then the degree indicated by the pointer is:

$$\{ (30 - [Zero]) / ([Span] - [Zero]) \} * ([End degree] - [Start degree]) =$$

$$\{(30 - 0) / (100 - 0)\} * (360 - 0) = 108$$

Pointer will be pointing at 108 degrees.

Example 2: Dynamic Limits

The low limit and high limit are set by the register.

Suppose the address is LW-n, the following table shows the read address of low limit and high limit:

Content	16-bit	32-bit	64-bit (cMT / cMT X only)
Low limit	LW-n	LW-n	LW-n
High limit	LW-n+1	LW-n+2	LW-n+4

For instance, when address is LW-100, the rule of setting limits is:

Content	16-bit	32-bit	64-bit (cMT / cMT X only)
Low limit	LW-100	LW-100	LW-100
High limit	LW-101	LW-102	LW-104

13.16.2.2. cMT / cMT X Series

General Tab

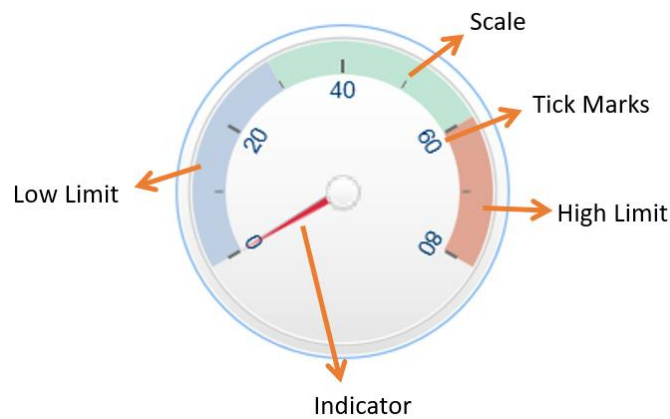
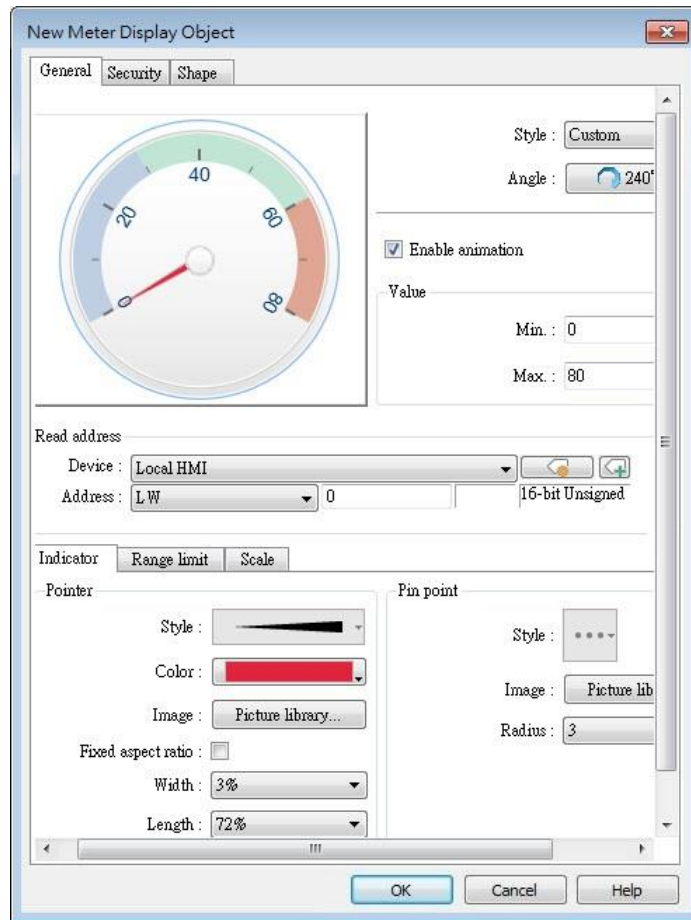

Setting	Description
Style	<p>Select a style from the drop-down list. Available options include: [Custom], [Style 1], [Style 2], and [Classical]. If [Custom] is selected, properties such as the width / length of the pointer or the radius of the pin point, etc must also be manually set.</p> <p>The following background-related settings are available using [Style 1], [Style 2], or [Classical]:</p> <p>Color Sets the color of the background picture of meter.</p> <p>Outline The following is the outline of Style 1 when [Full circle], [Half circle], or [Quarter circle] is selected.</p> <div data-bbox="504 779 1193 981" data-label="Image"> </div> <p>The following is the outline of Style 2 when [Full circle], [Half circle], or [Quarter circle] is selected.</p> <div data-bbox="504 1104 1109 1305" data-label="Image"> </div> <p>Rotation Rotates the background picture clockwise according to the angles set.</p>
Angle	<p>Direction Sets the range to label the scale, using twelve o'clock direction as the 0° reference.</p> <p>Degree Available options include: [Predefined] and [Custom]. With [Predefine] selected, pick from the thumbnails configure directions and angle ranges with ease.</p>

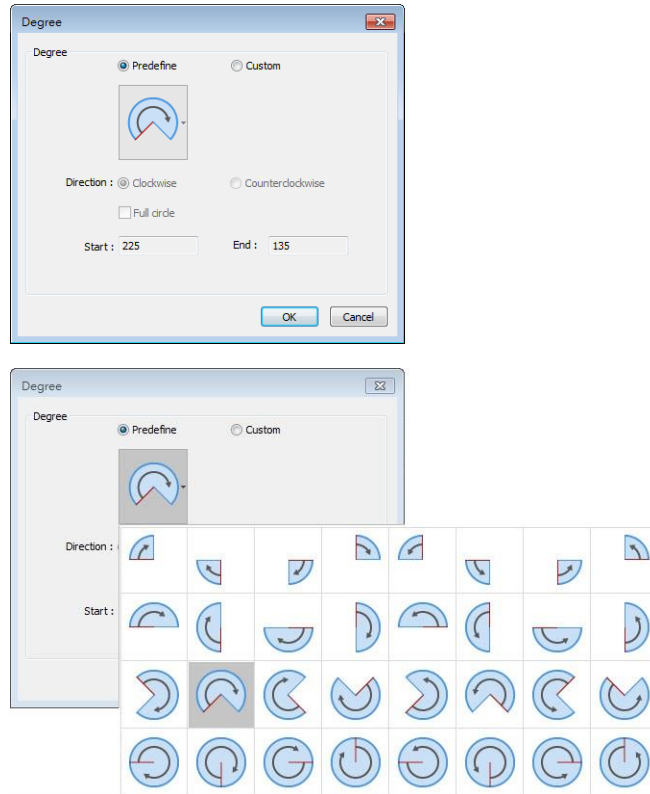

Full circle

If selected, the full circle is drawn according to the selected direction and the start angle. The limits are determined by the value set in [Minimum] and [Maximum] field under [Value].

Enable animation	If selected, the pointer slides to the designated position when the read value changes; if not selected, the pointer directly points to the designated position when the read value changes.
Value	Sets the lower and upper limits of the meter.
Read address	Displays the value in meter according to the value in the designated word register.
Indicator	Sets the style of pointer and pin point. If [Custom] is selected, the direction of the pointer must points upward to correctly display.
Range limit	Sets the values for low and high limits and the colors for alert indications. Dynamic limits The low and high limits are determined by specified registers. See Example 2 in the previous section. If the option to use different addresses is selected, the limits can be configured to read from different registers.
Scale	Sets the number of main and sub scale, the color of tick marks and scale label.

13.17. Trend Display

13.17.1. Overview

Trend display objects draw curves of the data recorded by Data Sampling object.

13.17.2. Configuration



Click [Data/History] » [Trend Display] icon on the toolbar to open a Trend Display object property dialog box. Set up the properties, press OK button, and a new Trend Display object will be created.

13.17.2.1. eMT, iE, XE, mTV Series

General Tab

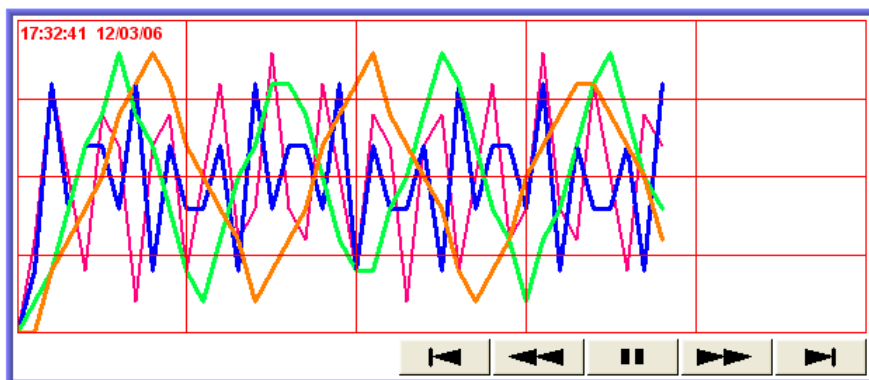

Button	Description
	Go to the earliest sampling data.
	Go to the previous time interval.
	Click to stop auto-scrolling. When the new sampling data is generated, the display does not scroll, nor is the new data outside the display range displayed.
	Click to start auto-scrolling. The display scrolls as the new sampling data is generated.
	Go to the next time interval.
	Go to the latest sampling data.

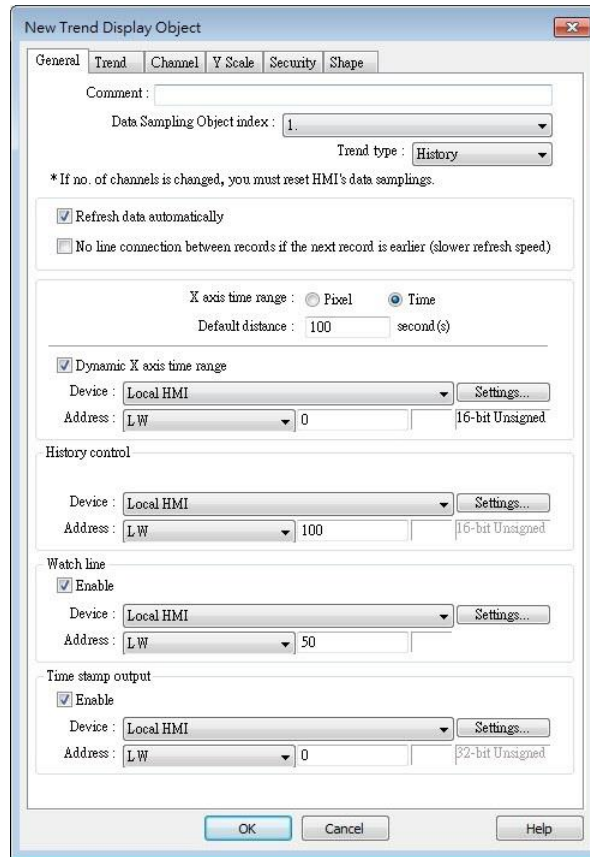

Setting	Description
Data Sampling Object index	Select a Data Sampling object as the source data.
Refresh data automatically	In history mode, when this option is selected, Trend Display will be automatically refreshed every 10 seconds. If this option is not selected, Trend Display can only be refreshed by changing window.
No line connection between records if the next record is earlier	When HMI time is adjusted to an earlier time, and data sampling keeps going on, selecting this option can prevent the system from drawing a line to connect the gap between current trend curve (earlier in time axis) and former trend curve (later in time axis). This can slow down refresh speed.
Trend type	Select the mode of data source, either [Real-time] or [History]. Real-time In this mode, the display object shows all sampled data since the HMI started. The maximum number of records that can be sampled is set in [Max.data records] (Real-time mode) of the Data Sampling object. When the sampling data exceed this setting, the earlier data will be deleted. To show older data, use [History] mode. [Hold control]: Suspends the update of Trend Display. However, it

does not stop the sampling process of Data Sampling object.

History

In this mode, the data comes from the history data files stored on HMI. The history data files are sorted by dates, and each is given an index. The system uses [History control] to select the history data files that are created on different dates.

The system sorts the history data of sampling data by date; the latest file is record 0 (typically the data sampled today), the second latest file is record 1, and so on. If the value of designated register in [History control] is n, the Trend Display object will display data record n.

Here is an example to explain [History control]. If the designated register is LW-0, and the sampling data files available are pressure_20061120.dtl, pressure_20061123.dtl, pressure_20061127.dtl, and pressure_20061203.dtl, and it is 2006/12/3 today, based on the value of LW-0, the sampling data file which will be selected by [Trend Display] is shown as follows:

Value of LW-0	Selected sampling history data
0	pressure_20061203.dtl
1	pressure_20061127.dtl
2	pressure_20061123.dtl
3	pressure_20061120.dtl

If use with Option List object and select data source as [Dates of historical data], the history data will be sorted by date and displayed in Option List object, see “13.29 Option List”.

Pixel

[Distance] is used to set the distance between two sampling points, as shown in the following figure.

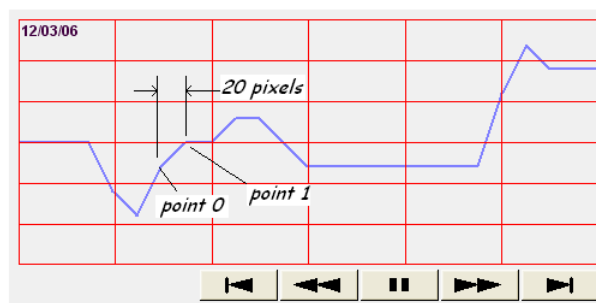

Time

[Distance] is used to set the X-axis in unit of time, as shown in the following figure.

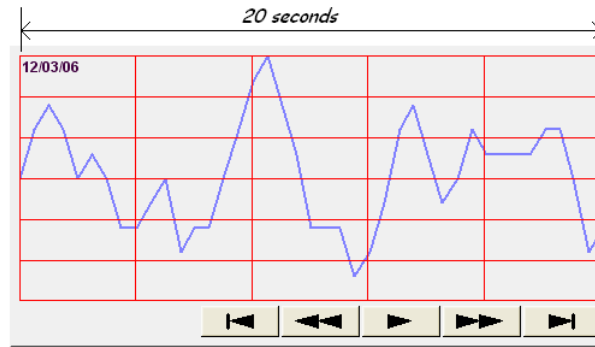





Select [Time] for [X axis time range] and go to [Trend] » [Grid] and enable [Time scale]. Please refer to [Time scale] in the later section.

**Dynamic distance between data samples/
Dynamic X axis time range**

Designate a 32-bit word register for adjusting the distance between two sampling points (select Pixel), or the time unit represented by X-axis (select Time). If no value is entered, the default value will be used.

Refresh data automatically

If selected, every time when opening the window on which the Trend Display object in history mode is placed, the display is automatically refreshed every 10 seconds. Please note that:

- The refresh status can be observed from the control button of Trend Display object.
Showing  button: The automatic refresh feature is enabled.
Showing  button: The automatic refresh feature is disabled.
- When scrolling to the previous data, the automatic refresh feature is disabled, the  button is shown.
- If [Refresh data automatically] check box is selected, when change back to the window, the display is refreshed, ignoring the control buttons. For example, select [Refresh data automatically], and scroll to the previous data, the automatic refresh feature is disabled. In this case, changing to another window and then change back will still refresh the display.
- If [Refresh data automatically] check box is not selected when building the project, the feature can still be enabled by pressing  button on HMI. In this case, the automatic refresh feature is disabled, that is, even when change back to the current window, the display will not be refreshed.

Hold control

When the register is set ON, suspend the update of Trend Display. It

does not stop the sampling process of Data Sampling object. This setting is available only in Real-time mode.

Watch line

Use the [Watch line] function to display a “watch line” when user touches the Trend Display object. It will also export the sampling data at the position of watch line to the designated word device and use Numeric objects to display the results, as shown in the following figure.

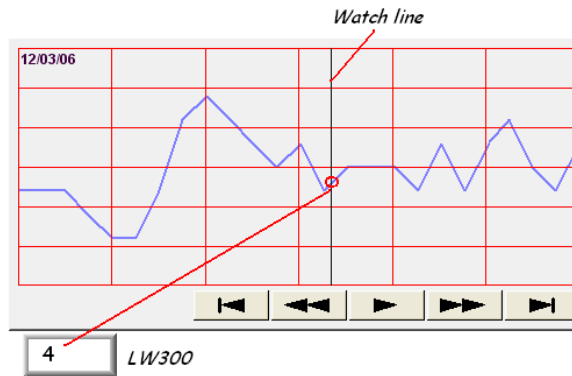

[Watch line] can also export sampling data with multiple channels. The system will consecutively write each channel to the specified address and the following addresses, in the same order as in [Data Sampling] object. The address assigned to [Watch line] is the start address, and sampling data for each channel will be exported to the word devices starting from “start address.” If the data format of each channel is different, the corresponding address of each channel is arranged from the first to the last. If the watch register is LW-300, watch function will export each channel’s data to the following addresses:

Register	Channel	Data format
LW-300	0	16-bit Unsigned (1 word)
LW-301	1	32-bit Unsigned (2 words)
LW-303	2	32-bit float (2 words)
LW-305	3	16-bit Signed (1 word)

Time stamp output

Time stamp output

Suppose the address is set to LW-n, then:

If enabled, the system will use the time of the first sampling data as “time origin”, and write the time stamp of the most recent sampled data (relative to “time origin”) to [LW-n+2].

When clicking on the curve, the time stamp of the closest sampled point will be written to [LW-n].

Clear real-time data address (Data Sampling object) will clear the

time origin as well.

Time stamp is recorded in seconds.

Trend Tab

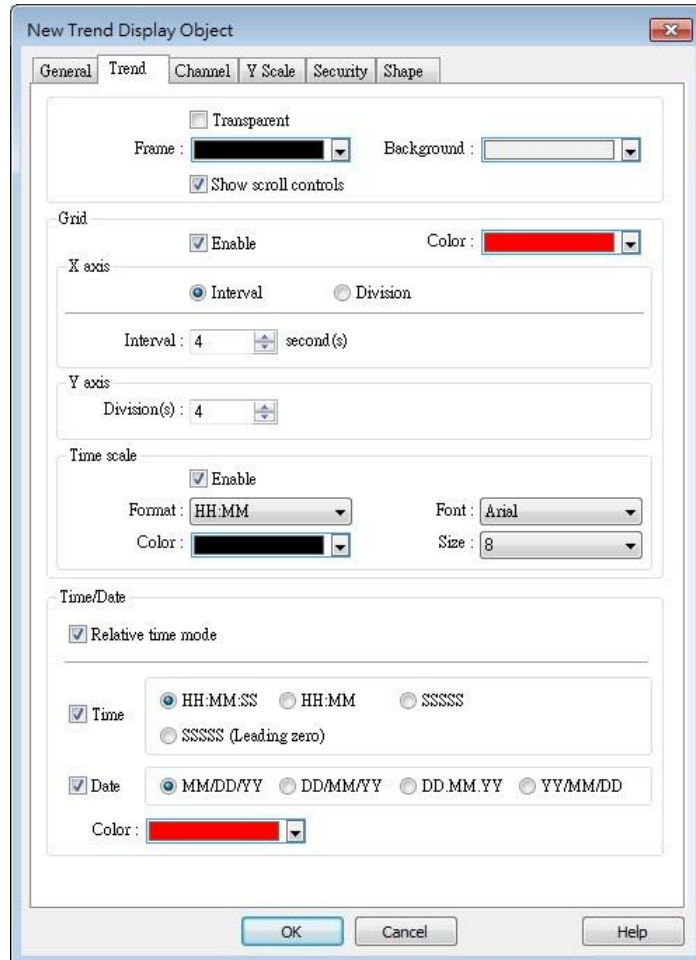

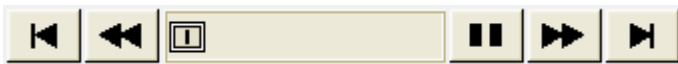
Setting	Description
Transparent / Frame / Background	Select the color of frame and background.
Show scroll controls	Enable or disable the scroll control as shown in the following figure. 
Grid	Set the number of dividing lines and the line color. The number of divisions depends on the setting in General tab » [Distance between data samples] / [X axis time range]. X-axis interval The number of vertical grid lines. <ul style="list-style-type: none"> Select [Distance between data samples] in General tab:

Select how many sampling points will be included between two vertical grid lines.

- Select [X axis time range] in General tab:

Select the time range between two vertical grid lines.

X-axis division

The number of vertical grid lines.

Y-axis division

The number of horizontal grid lines.

Time scale

Select [Time] / [Date] check box to display the time scale along the x axis.

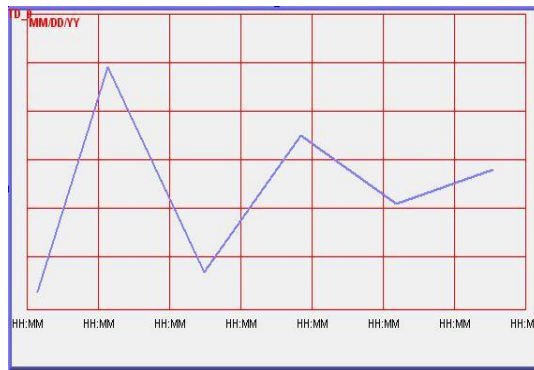

Font / Color / Size

Select the font, font color, and font size of the time scale.

The default font size is 8.

Time / Date

Relative time mode

When this mode is selected, the time of the earliest sampling data will be the start time from which to count a relative time. This mode works with time scale [SSSSSS] and under this mode, time scale [Date] cannot be used.

Y axis
 Division(s) : 4

Time scale
 Time SSSSSS
 Date
 Font : Arial Size : 8
 Color : [Black]

Time/Date
 Relative time mode
 Time HH:MM:SS
 Date YY/MM/DD
 Color : [Red]

The time of the latest sampling data will be marked on the top left corner of the object. This group box is used to set the time / date display format and font color.

Channel Tab

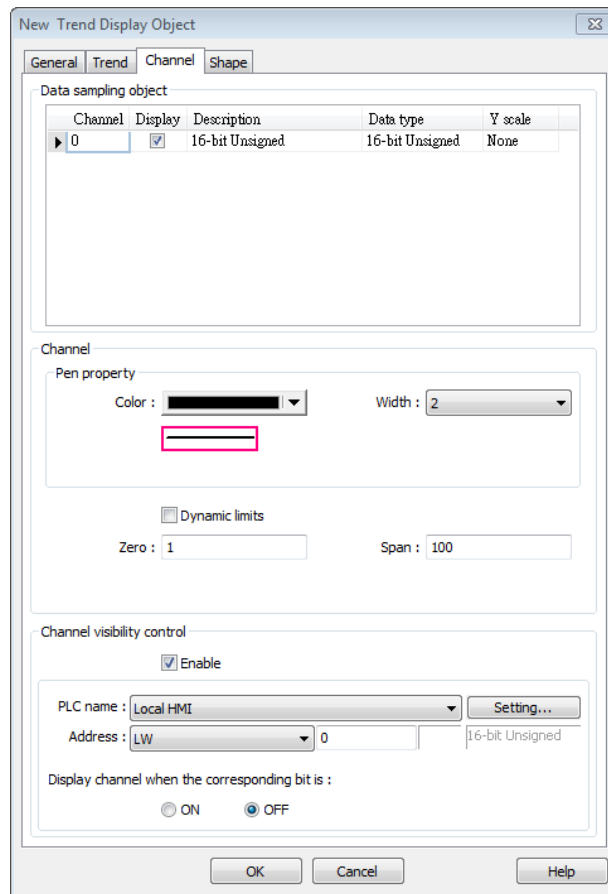

Setting	Description
---------	-------------

Y scale	Set Y-axis to be Main Axis or Aux. Axis. See “Y Scale Tab” for more information.
----------------	--

Channel	Display	Description	Data type	Y scale
1	True	channel A	16-bit Unsigned	Aux. Axis
2	True	channel B	16-bit Unsigned	Main Axis
3	True	channel C	16-bit Unsigned	Aux. Axis

Channel	Configure each sampling line’s format and color.
----------------	--

Dynamic limits

- Not selected:

[Zero] and [Span] are used to set the low limit and high limit of sampling data. If the low limit is 50 and the high limit is 100 for one sampling line, [Zero] and [Span] must be set as [50] and [100], so that all the sampling data can be displayed in the trend display object.

- Selected

The low limit and the high limit are read from the designated word devices, as shown below. When address is LW-n, the register’s address:

Data Format	16-bit	32-bit	64-bit (cMT / cMT X only)
Low limit	LW-n	LW-n	LW-n
High Limit	LW-n+1	LW-n+2	LW-n+4

For example, if LW-100 is used here, the low limit and the high limit will be read from:

Data Format	16-bit	32-bit	64-bit (cMT / cMT X only)
Low limit	LW-100	LW-100	LW-100
High Limit	LW-101	LW-102	LW-104

A typical usage of this is to zoom in and zoom out of Trend Display. (Not available for cMT / cMT X Series). See Example 1.

Channel visibility control

If [Enable] is selected, the bits of the assigned word register will be used to show/hide each channel. The first bit controls the first channel, and the second bit controls the second channel, and so on. For example, suppose there are 5 channels and LW-0 is used, channels which will be shown given the states of the control bits are:

Channel	Control Bit	State	Displayed
1	LW_bit-000	OFF	YES
2	LW_bit-001	ON	NO
3	LW_bit-002	ON	NO
4	LW_bit-003	OFF	YES
5	LW_bit-004	OFF	YES

Note on using this feature: Each control bits are not reserved for the channel. If a particular channel is not displayed, the control bit is assigned to the next displayed channel. For example, if the third channel of the 5 channels is not displayed, only 4 channels will be displayed in Trend Display, and the used control bits will only be: LW_bit-000~003.

Note

- A Trend Display can display up to 64 channels simultaneously.
- A Trend Display can only display channels with serial number ≤ 256 ; therefore, channels with serial number greater than 256 cannot be selected.

Y Scale Tab

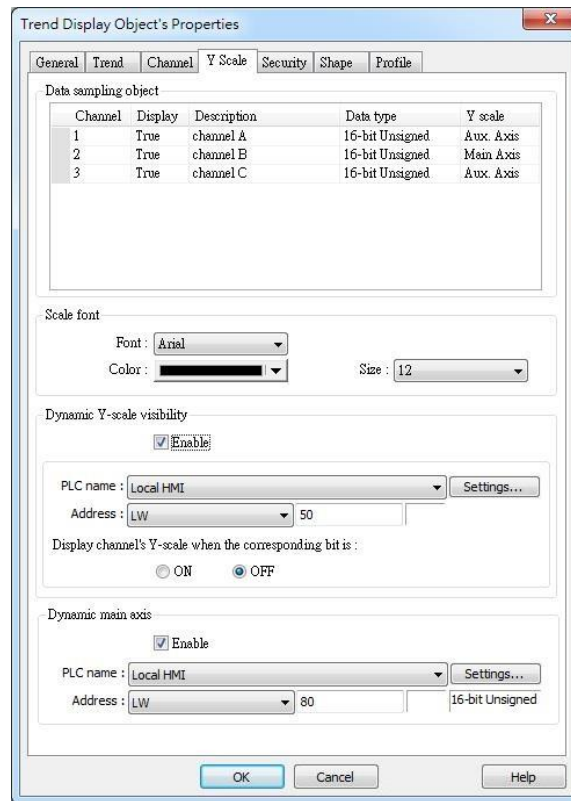

Setting	Description
Y scale	Show whether Y-axis is Main Axis or Aux. Axis. Y-axis will not be displayed when [none] is selected for Y scale in Data Sampling Object group box. At most 32 Y axes can be displayed, including one main axis and multiple aux. axes.
Scale font	Select the font, font color, and font size of the scale.
Dynamic Y-scale visibility	To show or hide Y-scale. If the control address is LW-50, then the first axis is controlled by LW_Bit 5000, and the second axis is controlled by LW_Bit 5001, and so on.
Dynamic main axis	To change the main axis. If writing 1 into LW-80, the main axis will be Channel 1; if writing 2 into LW-80, the main axis will be Channel, and so on.

Note

- A Trend Display on an eMT/iE/XE/mTV model can display 6MB of data in maximum.

13.17.2.2. cMT, cMT X Series

General Tab

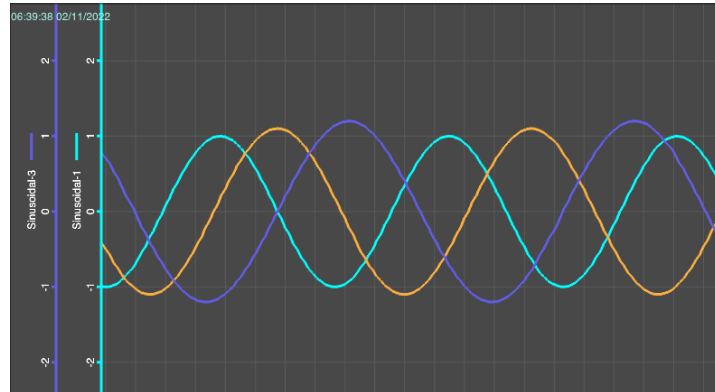

The Trend Display on cMT / cMT X Series combines Real-time mode and History mode. Drag left to scroll the Trend Display to view history data and drag right to view the latest sampling data. Pinch two fingers together to zoom out Trend Display or spread them apart to zoom in.

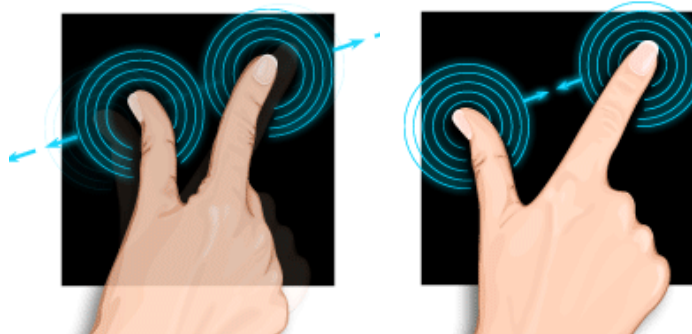

Zoom In

Zoom Out

 For more information about how sampling data is saved, see “8 Data Sampling”.

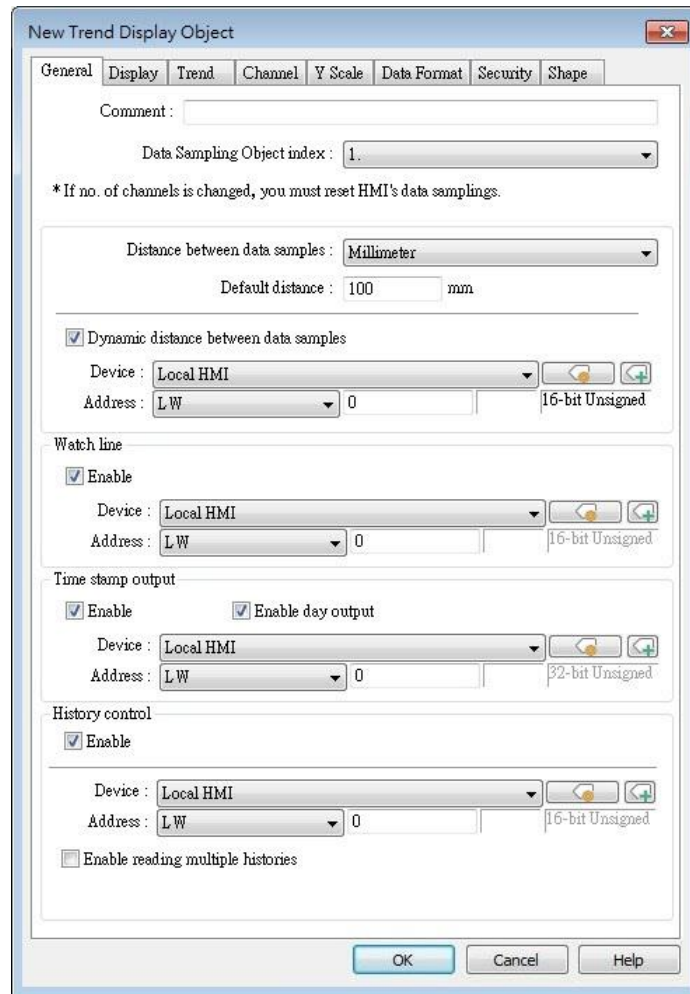

Setting	Description
Data Sampling Object index	Select a [Data Sampling] object as the source data.
Millimeter	Set the distance between sampling points, with a maximum of 500 mm.
Time	Set the time range displayed on the X-axis.
Pixel	Set the distance between sampling points in pixels, with a maximum of 1920 pixels.
Dynamic distance between data samples	Use a 32-bit word register to adjust the [millimeters], [pixels], or [time] distances dynamically. If no value is entered in the register, default values are used.
Watch line	When enabled, touching the Trend Display object creates a vertical line. The sampling data on this line is output to a specified address and displayed in the Numeric object. This feature can output multiple channel sampling data. The system sequentially writes the data based on the format defined in the

Data Sampling object, starting from the position specified by the watch line.

For example, if the Data Sampling includes several data formats and LW-300 is the register defined for the [Watch line] function, the data output addresses will correspond to the sampling data marked by the watch line:

Register	Channel	Data Type
LW-300	0	16-bit Unsigned (1 word)
LW-301	1	32-bit Unsigned (2 words)
LW-303	2	32-bit float (2 words)
LW-305	3	16-bit Signed (1 word)

Time stamp output

When enabled, the number of seconds passed from the first sampling data can be calculated.

Suppose the address is set to LW-n, then:

[LW-n]: The number of seconds passed from the first sampling data to the closest sampled point.

[LW-n+2]: The number of seconds passed from the first sampling data to the most recent sampling data.

Enable day output

With this option selected, the number of days passed since 1970/1/1 can be calculated.

Suppose the address is set to LW-n, then:

[LW-n+4]: The number of days passed since 1970/1/1 to the closest sampled point.

[LW-n+6]: The number of days passed since 1970/1/1 to the most recent sampling data.

History Control

This feature allows users to specify the data display based on a specific control address, enabling flexible management and viewing of historical data across different time periods. Below are detailed setup steps and examples.

Two Storage Methods for Historical Data:

All records in one file:

When sampling data is stored in a single file, the [History Control Address] indicates the current start date index. An index of 0 represents today, 1 represents yesterday, and so on.

- Enable reading multiple histories - Number of days
The value in [History Control Address + 1] specifies how many

days to display, calculated backward from the start date index.

- Enable reading multiple histories - Specific days

The value in [History Control Address + 1] indicates the end date index, which should be greater than the start date index.

For example, if the start index is 4 (4 days ago) and the end index is 7 (7 days ago), it displays data from 4 to 7 days ago.

Customized file handling

When sampling data is stored using this method, files are ordered based on the custom management settings, determining their age.

Users can control the displayed data through the [History Control Address]. If the data in the specified register is 0, the latest data is shown; if 1, the next latest, and so on.

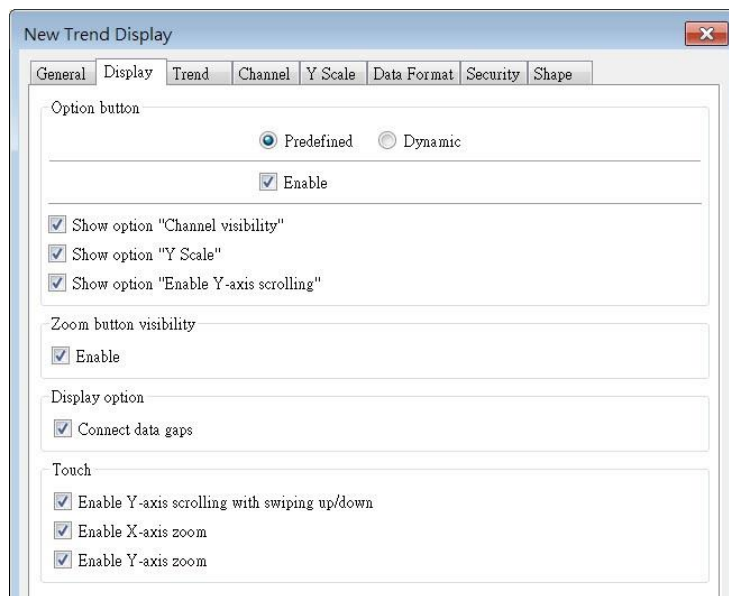

Display Tab



Setting	Description
Option button visibility (cMT Series)	Show or hide the option button  of the object.
	Predefined Select [Enable] to show the option button.
	Dynamic Choose a bit address to control option button visibility.

Option button visibility

Predefined Dynamic

Device : Local HMI  

Address : LB

Show option “Channel visibility”

With this option selected, the [Channel Visibility] setting will be displayed.

Show option “Y Scale”

With this option selected, the [Y Scale] setting will be displayed.

Show option “Enable Y-axis scrolling”

With this option selected, the [Enable Y-axis scrolling] setting will be displayed.

TREND DISPLAY SETTING	
Channel Visibility	
Y Scale	Off
Enable Y-axis scrolling	<input checked="" type="checkbox"/>

Zoom button visibility

Show or hide the zoom button  of the object.

Display option**Show custom file name**

This option appears when [Customized file handling] is selected in Data Sampling. With this option selected, the customized file name is shown as caption in Trend Display.

Connect data gaps

Data sampling stops when PLC is disconnected, and after PLC is reconnected, the trend curve of the disconnected period is plotted with a gap. With this option selected, the system will draw a line to connect the gap between the former trend curve (before disconnected period) and the current trend curve (after disconnected period).

Touch**Disable Y-axis scrolling with swiping up/down**

With this option selected, dragging the object with your finger will only scroll X-axis range while Y-axis remains being placed in the middle of the object even if it is zoomed in/out.

Disable X axis zoom

With this option selected, dragging the object with your finger will only scroll Y-axis range.

Disable Y axis zoom

With this option selected, dragging the object with your finger will only scroll X-axis range.

Trend Tab

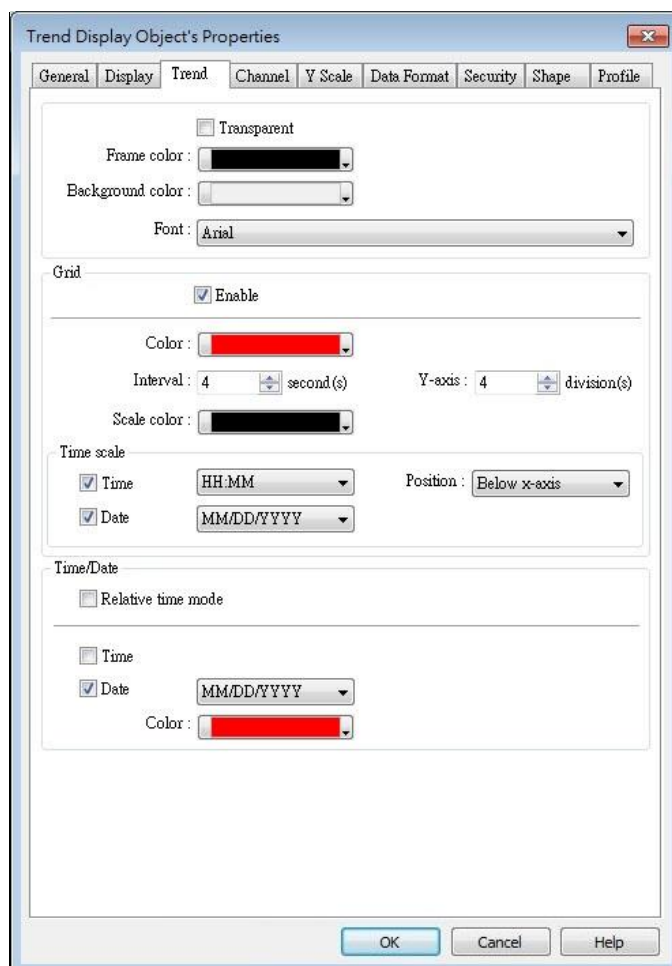

Setting	Description
Transparent / Frame / Background	Select the color of frame and background.
Grid	Set the number of dividing lines and the line color. The number of divisions depends on the setting in General tab » [Distance between data samples] / [X axis time range].
	X-axis interval
	The number of vertical grid lines.
	<ul style="list-style-type: none"> Select [Distance between data samples] in General tab: Select how many sampling points will be included between two

vertical grid lines.

- Select [X axis time range] in General tab:

Select the time range between two vertical grid lines.

X-axis division

The number of vertical grid lines.

Y-axis division

The number of horizontal grid lines.

Time scale

Select [Time] / [Date] check box to display the time scale along the x axis. The position of the time scale can be selected.

The default font size is 8.

Time / Date

Relative time mode

When this mode is selected, the time of the earliest sampling data will be the start time from which to count a relative time. This mode works with time scale [SSSSSS] and under this mode, time scale [Date] cannot be used.

The time of latest sampling data will be marked on the top left corner of the object. This group box is used to set the time / date display format and font color.

Channel Tab

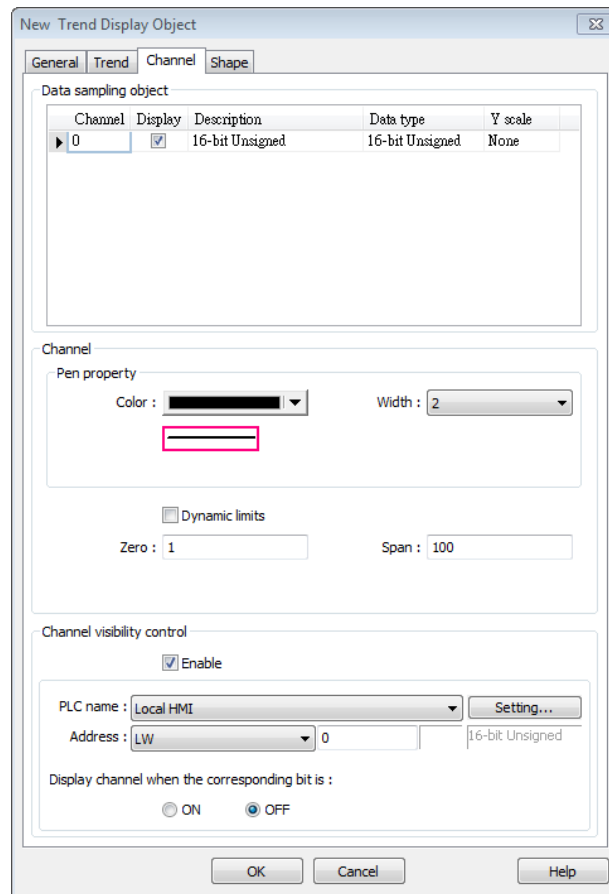

Setting

Y scale

Description

Set Y-axis to be Main Axis or Aux. Axis. See “Y Scale Tab” for more information. At most 32 Y axes can be displayed, including one main axis and multiple aux. axes.

Channel	Display	Description	Data type	Y scale
1	True	channel A	16-bit Unsigned	Aux. Axis
2	True	channel B	16-bit Unsigned	Main Axis
3	True	channel C	16-bit Unsigned	Aux. Axis

Channel

Configure each sampling line’s format and color.

Dynamic limits

- Not selected:

[Zero] and [Span] are used to set the low limit and high limit of sampling data. If the low limit is 50 and the high limit is 100 for one sampling line, [Zero] and [Span] must be set as [50] and [100], so that all the sampling data can be displayed in the trend display object.

- Selected

The low limit and the high limit are read from the designated word devices, as shown below. When address is LW-n, the register’s

address:

Data Format	16-bit	32-bit	64-bit (cMT / cMT X only)
Low limit	LW-n	LW-n	LW-n
High Limit	LW-n+1	LW-n+2	LW-n+4

For example, if LW-100 is used here, the low limit and the high limit will be read from:

Data Format	16-bit	32-bit	64-bit (cMT / cMT X only)
Low limit	LW-100	LW-100	LW-100
High Limit	LW-101	LW-102	LW-104

Channel visibility control

If [Enable] is selected, the bits of the assigned word register will be used to show/hide each channel. The first bit controls the first channel, and the second bit controls the second channel, and so on. For example, suppose there are 5 channels and LW-0 is used, channels which will be shown given the states of the control bits are:

Channel	Control Bit	State	Displayed
1	LW_bit-000	OFF	YES
2	LW_bit-001	ON	NO
3	LW_bit-002	ON	NO
4	LW_bit-003	OFF	YES
5	LW_bit-004	OFF	YES

Note on using this feature: Each control bits are not reserved for the channel. If a particular channel is not displayed, the control bit is assigned to the next displayed channel. For example, if the third channel of the 5 channels is not displayed, only 4 channels will be displayed in Trend Display, and the used control bits will only be: LW_bit-000~003.

Note

- A Trend Display can display up to 64 channels simultaneously.
- A Trend Display can only display channels with serial number ≤ 256 ; therefore, channels with serial number greater than 256 cannot be selected.

Y Scale Tab

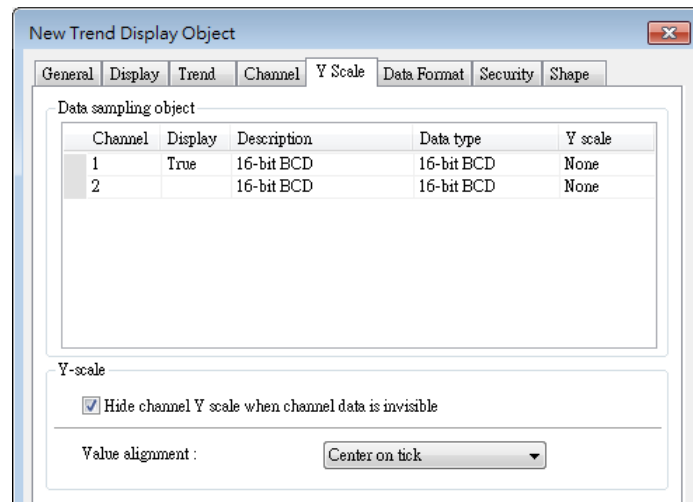

The scale along the Y axis of a specific channel can be displayed. To enable Y Scale, [Grid] should first be enabled in [Trend] tab.

Setting	Description
Y Scale	<p>Hide channel Y scale when channel data is invisible</p> <p>This option is selected by default. With this option selected, whether channel Y scale is shown or hidden is determined by the settings in Channel Visibility Control.</p> <p>Value alignment</p> <p>Set the alignment of Y axis tick values.</p> <p>Center on tick Full text</p>

Y Scale can be configured on the in cMT Viewer as shown in the following steps.

1. Tap the  button on the upper right corner of Trend Display object.
2. Tap [Trend Display Setting] » [Y Scale].

Cancel	Option	Done
	Begin Date	<input type="checkbox"/>
	Ended Date	<input type="checkbox"/>
TREND DISPLAY SETTING		
	Channel Visibility	
	Y Scale	On
	Disable Y-axis scrolling	<input type="checkbox"/>
Reset to default		

3. Set channel visibility.

Option	Channel Visibility
	Channel 1 <input type="checkbox"/>
	Channel 2 <input type="checkbox"/>
	Channel 3 <input type="checkbox"/>
	Channel 4 <input type="checkbox"/>
	Channel 5 <input type="checkbox"/>

Data Format Tab

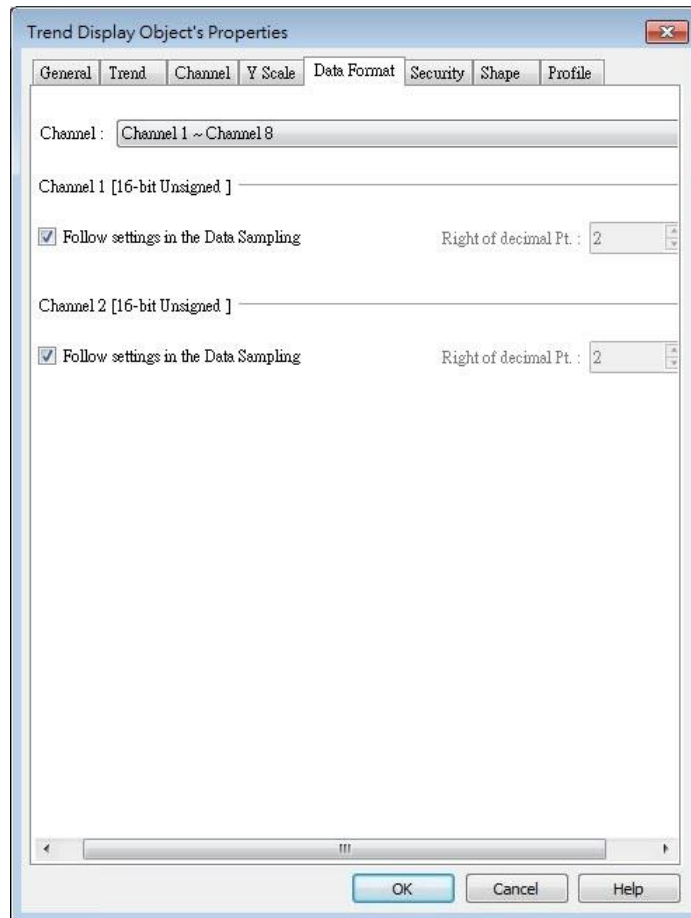

Setting	Description
Follow settings in the Data Sampling	Use the [Right of decimal Pt.] setting in Data Sampling.
Right of decimal Pt	The number in this field determines the number of decimal places of the value displayed; for example, when 1 is entered in this field, and the original value obtained by Data Sampling is 45, then 4.5 will be displayed in Trend Display as a result.

Example 1

The example explains how to zoom in or zoom out Trend Display. The feature described is not available for cMT / cMT X Series.

In Channel tab select [Dynamic limits] check box. If the [Address] is set to LW-n, then LW-n controls the low limit where LW-n+1 controls the high limit.

Dynamic limits

PLC name : Local HMI Setting...

Address : LW 16-bit Unsigned

Set [Address] to LW-0 and create two Numeric objects for entering the low / high limit. The address that controls the low limit is LW-0; the address that controls the high limit is LW-1. Let's suppose the data is between 0 and 30; set the [Low limit] to 0 and the [High limit] to 30, the trend curve is displayed as shown in the following figure.



To zoom out the Trend Display, enter a value greater than 30 in [High limit] as shown in the following figure.

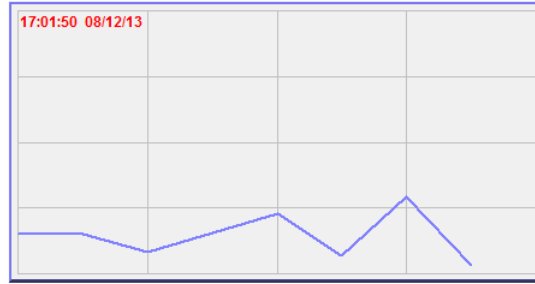

Low limit

0

High limit

100

To zoom in the Trend Display, enter a value less than 30 in [High limit] as shown in the following figure.

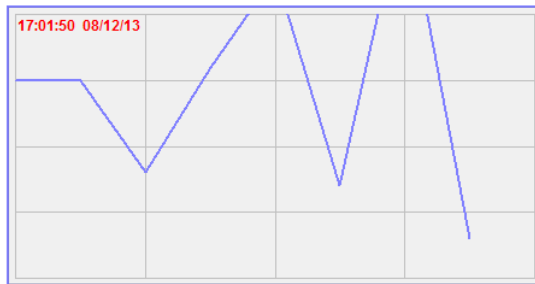

Low limit

0

High limit

20

13.18. History Data Display

13.18.1. Overview

History Data Display object displays data stored by Data Sampling object. It differs from Trend Display in that History Data Display object uses a table to display data. The following is an example of a history data display object.

No.	Time	Date	Ch.0	Ch.1	Ch.2
3577	21:52	16/09/07	0	0	0
3576	21:52	16/09/07	0	0	0
3575	21:52	16/09/07	0	0	0
3574	21:52	16/09/07	0	0	0
3573	21:52	16/09/07	0	0	0
3572	21:52	16/09/07	0	0	0
3571	21:52	16/09/07	0	0	0
3570	21:52	16/09/07	0	0	0
3569	21:52	16/09/07	0	0	0
3568	21:52	16/09/07	0	0	0

A History Data Display on an eMT/iE/XE/mTV model can display 6MB of data in maximum. The data will not be displayed after exceeding the limit.

13.18.2. Configuration



Click [Data/History] » [History Data Display] icon on the toolbar to open a History Data Display object property dialog box. Set up the properties, press OK button, and a new History Data Display object will be created.

General Tab

cMT, cMT X

eMT, iE, XE, mTV

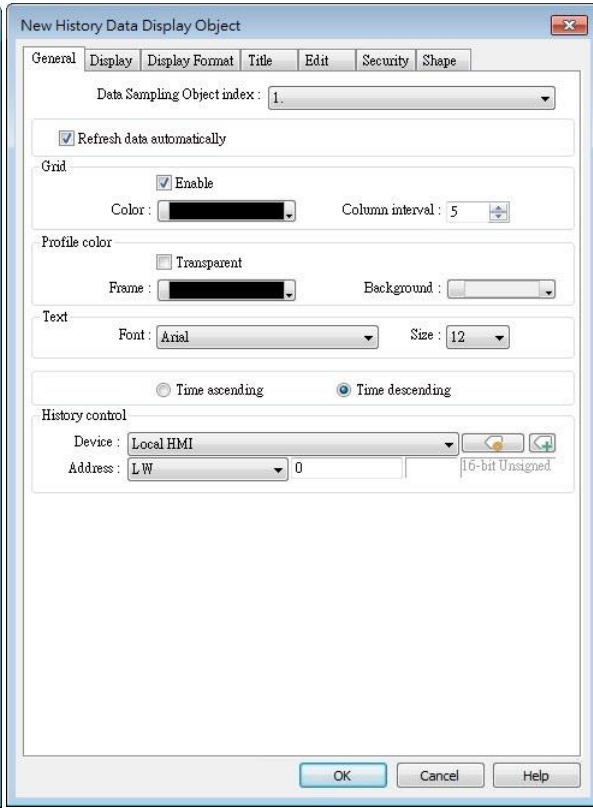
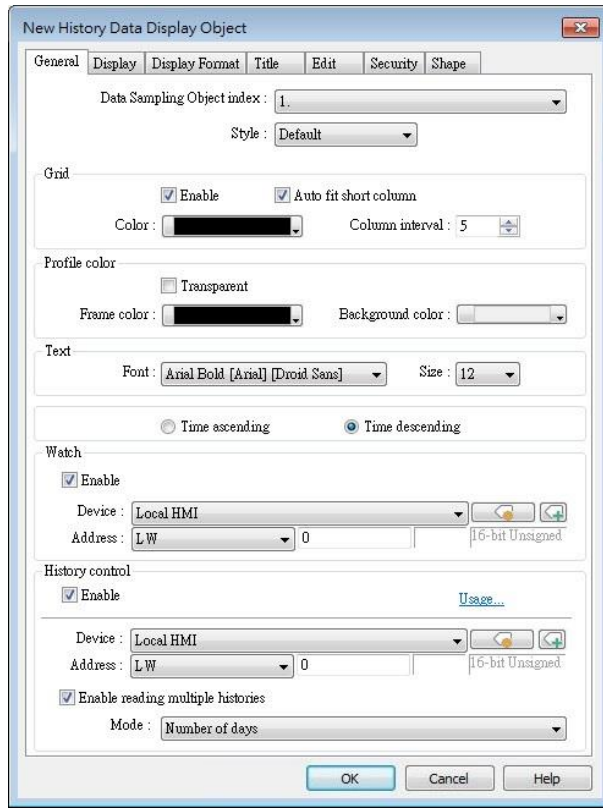

Setting	Description
Data Sampling object index	Select a Data Sampling object as the source data.
Refresh Data Automatically	The system will refresh data every 10 seconds. When this option is not selected, data can be refreshed only by changing windows.
Style	Select History Data Display object's style.
Grid	Shows grids between rows and columns.
Color	Change the color of grids.
Column interval	Change the width of each column. The figures below are the examples.

No.	Time	Date	Ch.0	Ch.1	Ch.2
3667	21:57	16/09/07	1	0	0
3666	21:57	16/09/07	1	0	0
3665	21:57	16/09/07	1	0	0
3664	21:57	16/09/07	1	0	0
3663	21:57	16/09/07	1	0	0
3662	21:57	16/09/07	1	0	0
3661	21:57	16/09/07	1	0	0
3660	21:56	16/09/07	0	0	0
3659	21:56	16/09/07	0	0	0
3658	21:56	16/09/07	0	0	0

No.	Time	Date
3667	21:57	16/09/07
3666	21:57	16/09/07
3665	21:57	16/09/07
3664	21:57	16/09/07
3663	21:57	16/09/07
3662	21:57	16/09/07
3661	21:57	16/09/07
3660	21:56	16/09/07
3659	21:56	16/09/07
3658	21:56	16/09/07

Profile color	Change the color of frame and background. Use [Transparent] to hide frames and background.
Text	Change the font and font size.
Time / Date	<p>Time ascending Put earliest data at the top and the latest data at the bottom.</p> <p>Time descending Put the latest data at the top and the earliest data at the bottom.</p>
History Control (eMT, iE, XE, mTV Series)	The history files are sorted by date and each file is given an index. The latest one is assigned index 0 (in most cases: today), the second latest file is assigned index 1, and so on. [History Control] is used to specify the history data to be shown.
Watch (cMT / cMT X Series)	By tapping on a record in History Data Display object, data in the selected row can be output to the designated addresses.
History Control (cMT / cMT X Series)	<p>This feature allows users to specify the data display based on a specific control address, enabling flexible management and viewing of historical data across different time periods. Below are detailed setup steps and examples.</p> <p>Two Storage Methods for Historical Data:</p> <p>All records in one file:</p> <p>When sampling data is stored in a single file, the [History Control Address] indicates the current start date index. An index of 0 represents today, 1 represents yesterday, and so on.</p> <ul style="list-style-type: none"> ● Enable reading multiple histories - Number of days The value in [History Control Address + 1] specifies how many days to display, calculated backward from the start date index. ● Enable reading multiple histories - Specific days The value in [History Control Address + 1] indicates the end date index, which should be greater than the start date index. For example, if the start index is 4 (4 days ago) and the end index is 7 (7 days ago), it displays data from 4 to 7 days ago. <p>Customized file handling</p> <p>When sampling data is stored using this method, files are ordered based on the custom management settings, determining their age. Users can control the displayed data through the [History Control Address]. If the data in the specified register is 0, the latest data is shown; if 1, the next latest, and so on.</p>

 **Note**

- When using cMT / cMT X Series, use the gear icon in the upper-right corner of History Data Display object in cMT Viewer to select the date and display the data.

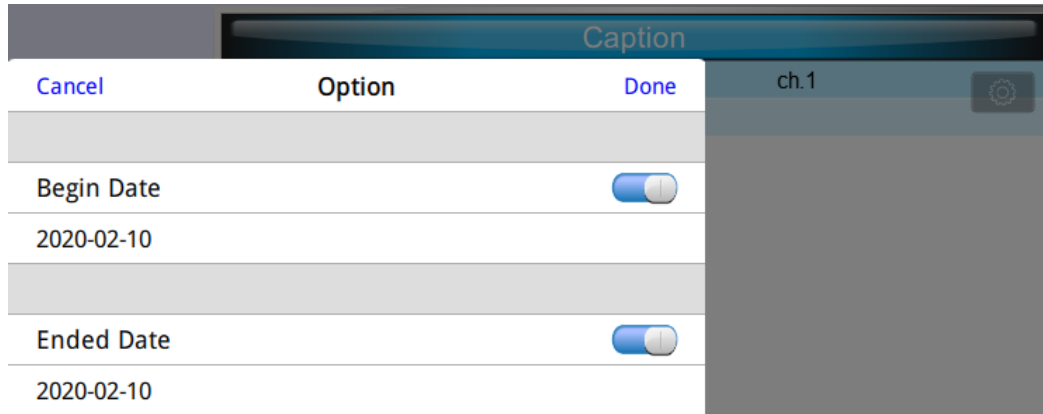



Display Tab

cMT, cMT X

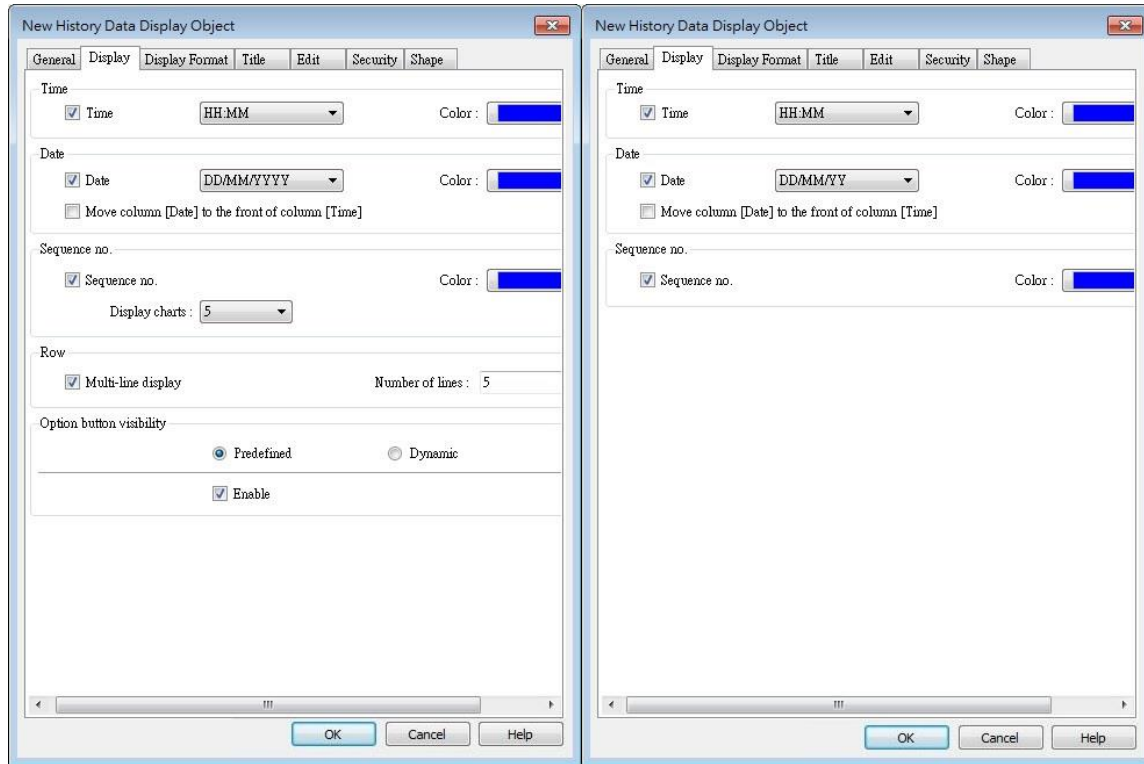
eMT, iE, XE, mTV



Setting	Description
Time / Date	<p>Enable or disable showing the time and date and configure its format and color.</p> <p>Move column [Date] to the front of column [Time] Swap the position of column [Date] and column [Time].</p>
Sequence no.	<p>Show the sequence number of all records.</p>
Row	<p>Multi-line display Display a specified number of lines of data. Data will be displayed as specified regardless of the actual number of lines of data.</p>
Option button visibility (cMT / cMT X Series)	<p>Show or hide the option button .</p> <p>Predefined Select [Enable] to show the option button.</p> <p>Dynamic</p> <div data-bbox="502 1780 1045 1937" style="border: 1px solid gray; padding: 5px;"> <p>Option button visibility</p> <p><input type="radio"/> Predefined <input checked="" type="radio"/> Dynamic</p> <hr/> <p>Device : Local HMI  </p> <p>Address : LB <input type="text" value="0"/></p> </div> <p>Designate a bit address to control option button visibility.</p>

Data Format Tab

cMT / cMT X Series

eMT, iE, XE, mTV Series

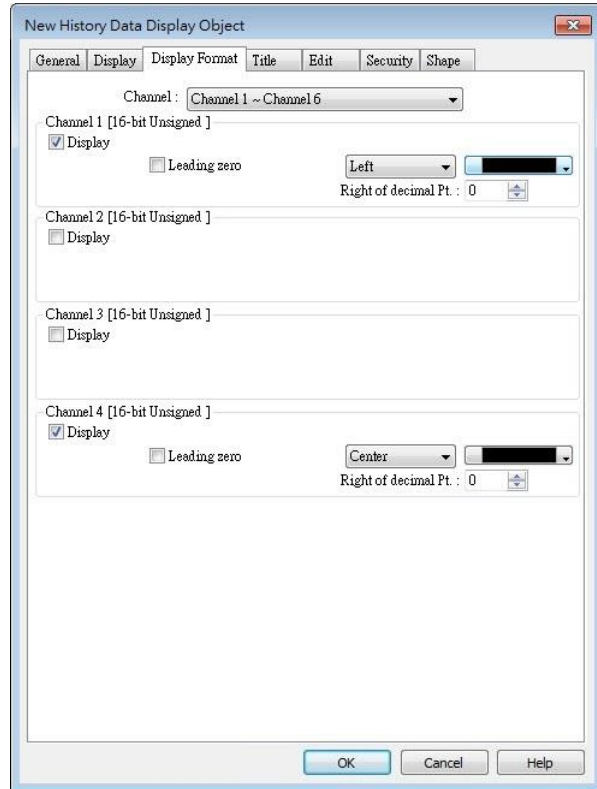
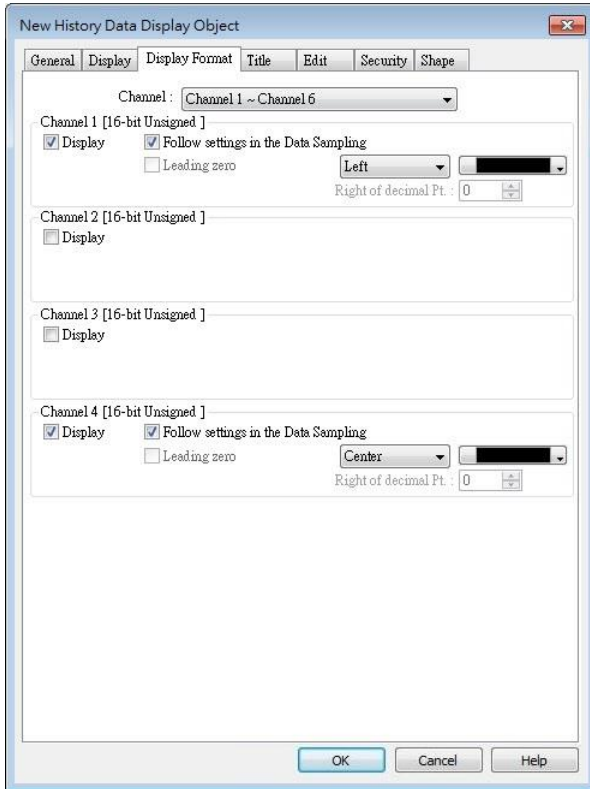

Setting

Description

Channel

Each History Data Display object can display up to 64 channels. Check [Display] to select the channels to be shown on the screen. In the figure above, there are 4 channels (channel 1 to channel 4) in the Data Sampling object, and only Ch.1 and Ch.4 are selected. The data formats are shown next to channel name. The data format of each channel is decided by the corresponding Data Sampling objects. The result is shown below:

No.	Time	Date	ch.1	ch
12	09:50:16	10/03/17	0	0
11	09:50:15	10/03/17	0	0
10	09:50:14	10/03/17	0	0
9	09:50:13	10/03/17	0	0
8	09:50:12	10/03/17	0	0
7	09:50:11	10/03/17	0	0
6	09:50:10	10/03/17	0	0
5	09:50:09	10/03/17	0	0

When using cMT / cMT X models, Data Sampling's Data Format settings can be applied to History Data Display object.

Two display modes are available when displaying [String] format in History Data Display object:

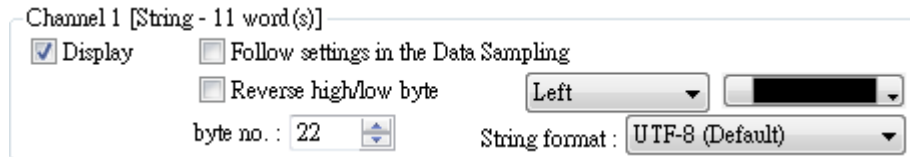

- Follow settings in the Data Sampling.
- Reverse high byte and low byte data and then display.

Title Tab

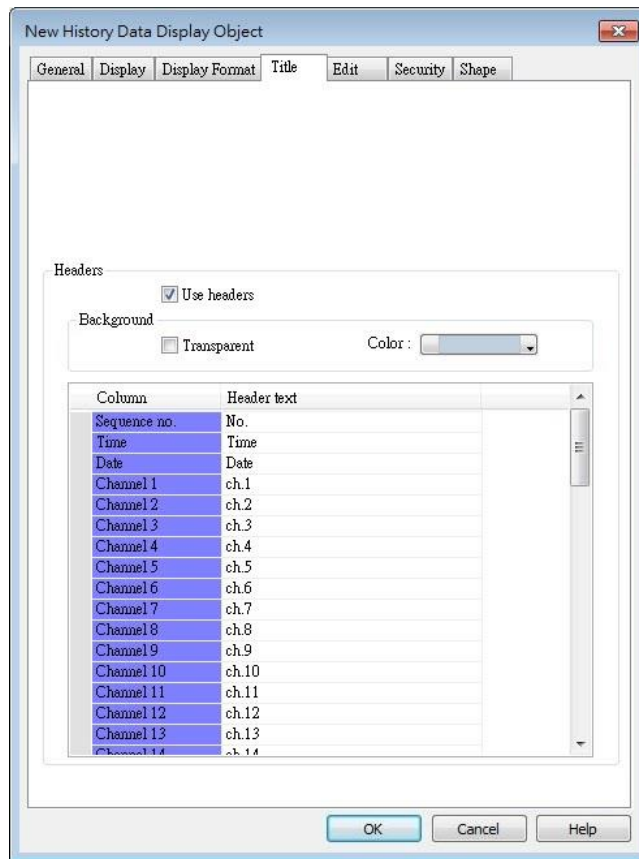

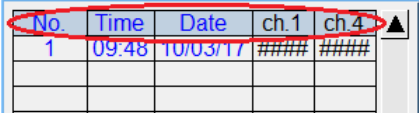
Setting	Description
Use headers	Enable or disable title, which is marked as shown below: 
Background	Transparent When selected, hide the background for title area. Color Set the background color of title.
Setting	Defines the text to be shown on the title. The text can be edited in Label Tag Library. Build the Label Tag Library first, and in History Data Display settings dialog select the checkbox in the Label Library column, and then select the label tag.

Title name	Label ...	Label tag	Title
Sequence no.	<input checked="" type="checkbox"/>	Label_1	No.
Time	<input type="checkbox"/>		Time
Date	<input type="checkbox"/>		Date
Channel 1	<input type="checkbox"/>		ch.1
Channel 2	<input type="checkbox"/>		ch.2
Channel 3	<input type="checkbox"/>		ch.3

 **Note**

- After running simulation on PC, to run simulation again using the same project that contains some changed data, please find the HMI_memory, SD_card, or usb1 folder in EasyBuilder Pro installation, and then delete the old data sampling records in it, to prevent the system from reading old data in the second simulation.

Edit Tab

cMT / cMT X Series

eMT, iE, XE, mTV Series

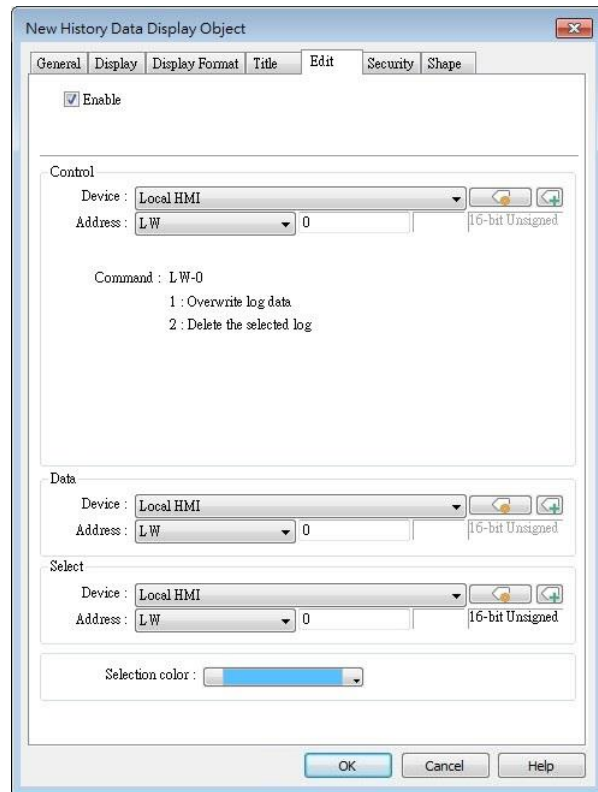
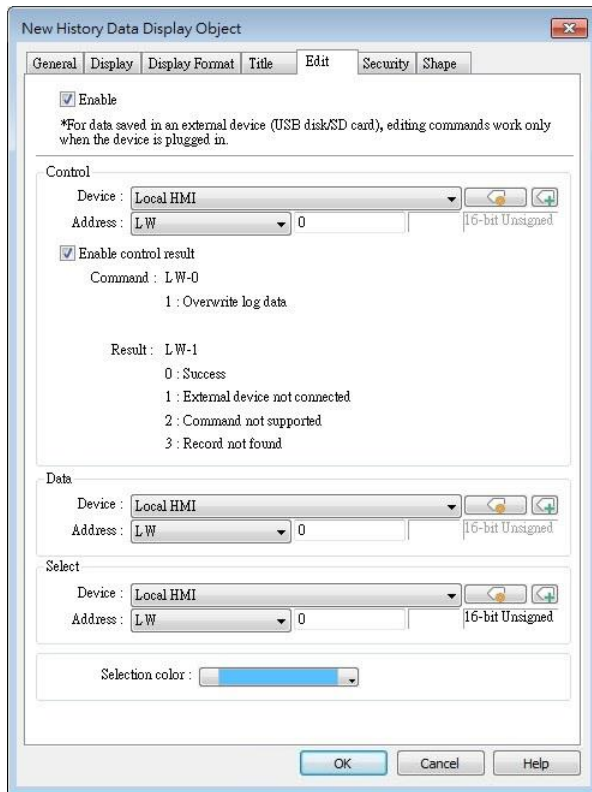

Setting

Description

Control address

LW-n: Command

Value	Description
1	The data in Data Address will overwrite the data in data log.
2	The selected data log will be deleted.

LW-n+1: Result (cMT / cMT X Series)

Value	Description
0	The command is executed successfully.
1	The external device is not connected.
2	The command is not supported.
3	The record cannot be found.

Data address

The system will start reading row by row from the selected one in History Data Display, and change the data log accordingly. Please note that the settings in this address must be identical to that in Data Sampling.

Select address

By changing the value in Select Address, the corresponding row in History Data Display can be selected.

Please note that:

1. When the value in Select Address is 0, no row will be selected, and the value in Data Address will stay the same as that of the previously selected row number.
 2. When the value in Select Address exceeds the total number of rows in History Data Display, the last row (the one with largest row number) will be selected.
-

 **Note**

- When an external device is used to save data log, removing the external device will make Edit function ineffective. Editing can keep on when the external device is inserted again and the system starts reading historical data.

13.19. Data Block Display

13.19.1. Overview

Data Block is a combination of several word devices with continuous address, where the X axis of Data Block Display object represents the address and the numbers on the Y axis represent the data values in the corresponding address. Data Block Display object can display multiple data blocks. For example, it can display two data blocks LW-12~LW-15 and RW-12~RW-15 in trend curves simultaneously. It is very useful to observe and compare the difference of trend curves.

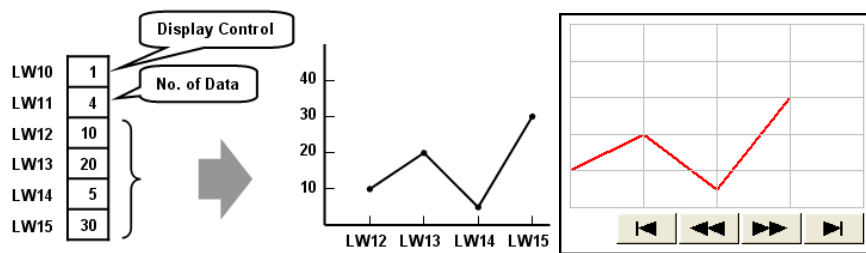

13.19.2. Configuration



Click the [Object] » [Chart] » [Data Block Display] icon on the toolbar to open the property dialog box. Set up the properties, press OK button, and a new Data Block Display object will be created.

General Tab

Setting	Description
Comment	Description of the object.
No. of channel	Set the no of channel for this object. Each channel represents one data block. The maximal number of channels is 12.
Watch Line	<p>If enabled, when user touches the [Data Block Display] object, it will display a vertical cursor line on it, and store the data on the line to the designated registers. See Example 1.</p> <p>Allow input (cMT / cMT X Series) With this checkbox selected, entering a value in the specified address for watch line can move the verticle watch line to the desired position.</p>
Channel	Select the channel to be configured.
Control address	<p>Specify the control address also the data source. Control address is used to control and clear the drawn curve. After executing the operation below, the system will reset the control word to zero.</p> <p>Enter "0" = No action (default) Enter "1" = Draw (Without clear first) Enter "2" = Clear</p>

Enter "3" = Redraw

No. of data address

If control address is LW-n, then LW-n+1 stores the number of word devices in each data block, i.e. the number of data. The maximum value is 1024.

Data storage start address

If [Offset to start address] is enabled, the [Offset value storage address] will be set as [Control address] + 2.

If select 16-bit data format, the address for each data will be start address, start address + 1, start address + 2 and so on.

If select 32-bit data format, the address for each data will be start address, start address + 2, start address + 4 and so on.

For more information about control address, see Example 2 to 5.

Limit

Set the minimum and maximum limit for the curve.

Note

- Without clearing the drawn lines, Data Block Display can be drawn a number of times by entering value 1 in the control address repeatedly. The way to calculate the maximum number of times is: 32 divided by the number of channels.

1 channel → 32 times

2 channels → 16 times

16 channels → 2 times

Example 1

How to use watch (Cursor Line) feature

Use "Watch" function to check the value of any point of the curve. When the user touches [Data Block] object, it will display a "cursor line", and the system will write the index and value of that data on the cursor line to the designated address.

Data Format	Index Value	Channel 1 Value	Channel 2 Value
16-bit	Address	Address + 1	Address + 2
32-bit	Address	Address + 2	Address + 4
64-bit (cMT / cMT X only)	Address	Address + 4	Address + 8

When watch address is set to LW-n, the value written into LW-n represents the channel index number to be called up. (Start form 0)

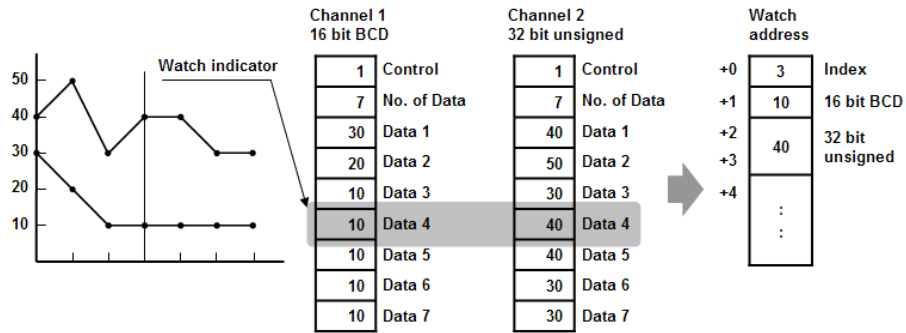

Note

- [Data Index] is a 16 bit unsigned integer. When the designated register of cursor line is 32 bit device, it will be stored in the bit 0-15.
- If the channel to be viewed has no data, "0" will be displayed, as shown below. In the example, there is no data in channel 1, when the cursor points at Data 4, "0" will be displayed as shown below.

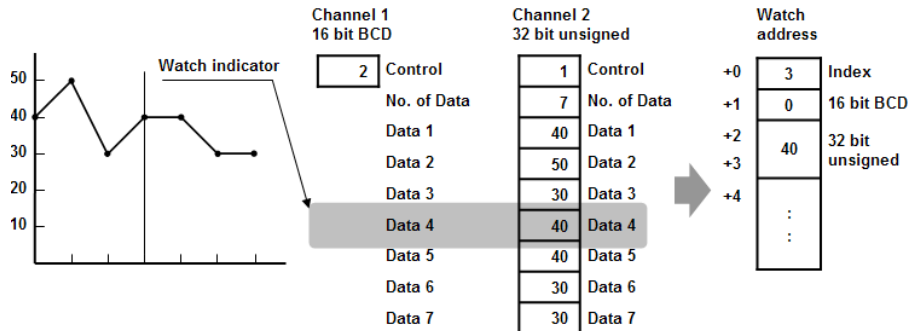

- If there is less data in Channel 1, "0" will be displayed, as shown below.

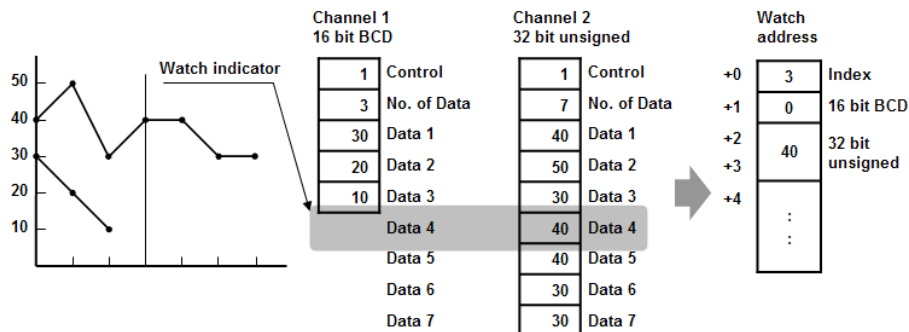

Example 2

How to show a data block

1. Write the number of data to [No. of data address], i.e. "Control address+1"
2. Store the data consecutively beginning at [Data storage start address].
3. Write "1" to [Control address] to draw the curve without cleaning the plot. All previous curves will not be erased.
4. The system will write "0" to [Control address] after marking the plot.

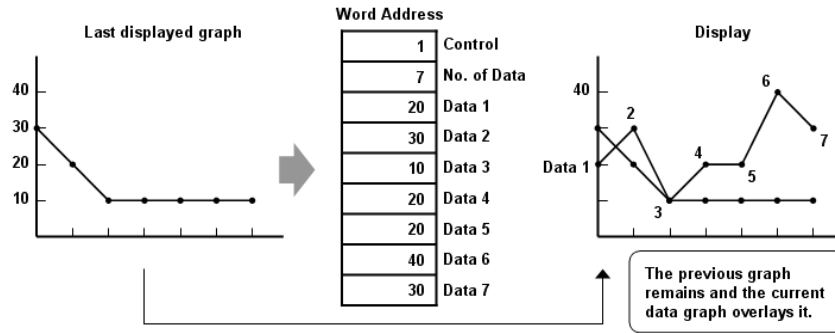

Note

- Do not change the content of [Control address], [No. of data address] and [Data storage start address] between step 3 and step 4 above as doing so might cause error for the trend curve plot.

Example 3

How to clear the graph

- Write "2" to [Control address], all the trend curves will be cleared.
- The system will write "0" to [Control address] after the trend curve is cleared.

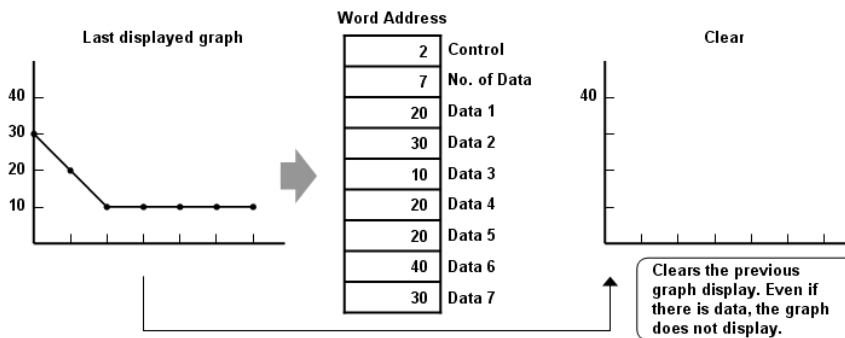

Example 4

How to clear the previous trend curve and display new one

- Write the number of data to [No. of data address], i.e. "control address+1"
- Store the data consecutively beginning at [Data storage start address].
- Write "3" to [Control address], the previous trend curves will be cleared and the new content in data block will be plotted on the screen.
- The system will write "0" to [Control address] after the trend curve has been plotted.

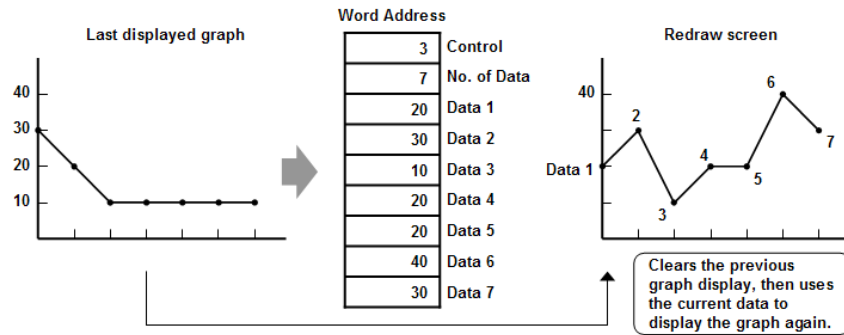

Example 5

How to use offset mode

If [Offset to start address] is selected, [Control address], [No. of data address], and [Offset value storage address] will use 3 consecutive addresses.

For example, assume the total number of channels is 3 (start from 0 to 2), and the [Control address] are LW-0, LW-100, and LW-200, respectively. Then, the other addresses will be set as follows: (In the example, format 16-bit Unsigned is used and [Offset value storage address] are all m).

Item	Channel 0	Channel 1	Channel 2
Control Address	LW-0	LW-100	LW-200
No. of data address	LW-1	LW-101	LW-201
Offset value storage address	LW-2 (=m)	LW-102 (=m)	LW-202 (=m)
Data 1	LW-0+m	LW-100+m	LW-200+m
Data 2	LW-1+m	LW-101+m	LW-201+m
...

The following figure on the left shows the result when offset mode is not used while the figure on the right shows the result when offset mode is used.

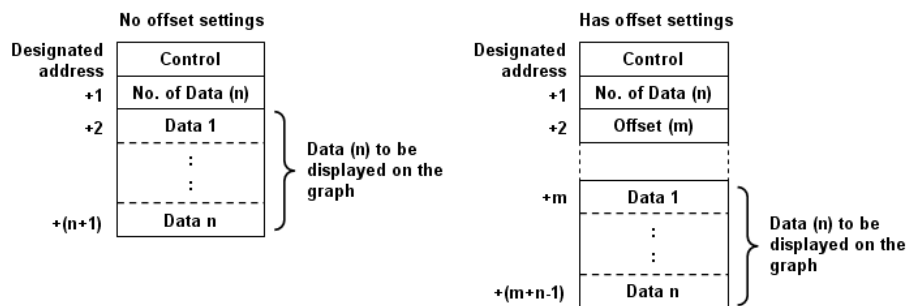

Note

- When [Control address] is set to LW-n, [No. of data address] and [Offset value storage address] are as follows:

Data Type	16-bit	32-bit	64-bit (cMT / cMT X only)
Control address	LW-n	LW-n	LW-n
No. of data address	LW-n+1	LW-n+2	LW-n+4
Offset value storage address	LW-n+2	LW-n+4	LW-n+8

- If the control registers are 32-bit devices, only bit 0-15 will be used for control purpose, bit 16-31 will be ignored. (as illustrated below)

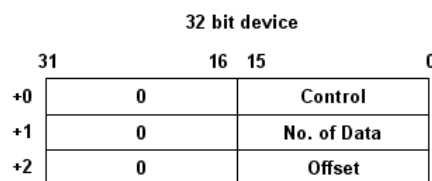

- When the value in [Control address] is not zero, the system will read [No. on data address] and [Offset value storage address].
- It is recommended to use [Offset to start address] for data block display with multiple

channels and the same device type. As shown in the following figure, The control words of channel 1 is located from LW-n, the control words of channel 2 is located from LW-n+3, and so on.

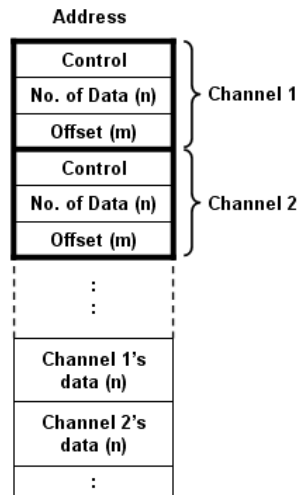

Display Area

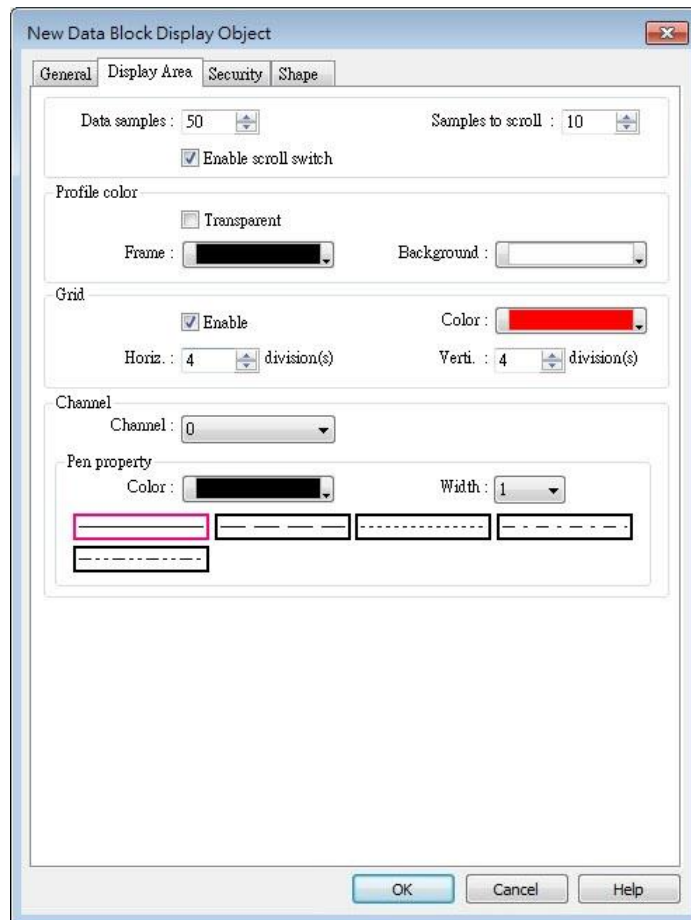

Setting	Description
Description	Data samples

Configure the maximal number of data samples (points) to be displayed.

Samples to scroll

Configure the number of data samples being scrolled.

Enable scroll switch

Clicking  displays the previous or next data point.

Clicking  displays the first or the last data point.

Profile

Set the color of the frame and background of the object.

Transparent

Hides the background. Color selection will not be available.

Grid

Set the number of horizontal and vertical divisions shown by grid.

Channel

Set the color, width and style of each curve.

13.20. XY Plot

13.20.1. Overview

XY Plot object is used to display values for two variables (x,y) for a set of data, where the data comes from word registers. Up to 16 channels can be displayed simultaneously. This object facilitates data observation and analysis. Additionally, negative numbers can be displayed as well.

13.20.2. Configuration



Click [Object] » [Chart] » [XY Plot] icon on the toolbar to open a [XY Plot] object property dialog box.

General Tab

XY Plot Object's Properties

General | Display Area | Shape | Profile

Comment :

Direction : Right No. of channels : 2

Control Address

PLC name : Local HMI Setting...

Address : LW 10

No. of data address : LW : 10 + 1

Channel : 0

Read address

PLC name : Local HMI

Separated address for X and Y data

X data

PLC name : Local HMI Setting...

Address : LW 100 16-bit Unsigned

Y data

PLC name : Local HMI Setting...

Address : LW 200 16-bit Unsigned

Limits

Dynamic limits

X axis

Low : 0 High : 32767

Y axis

Low : 0 High : 32767

OK Cancel Help

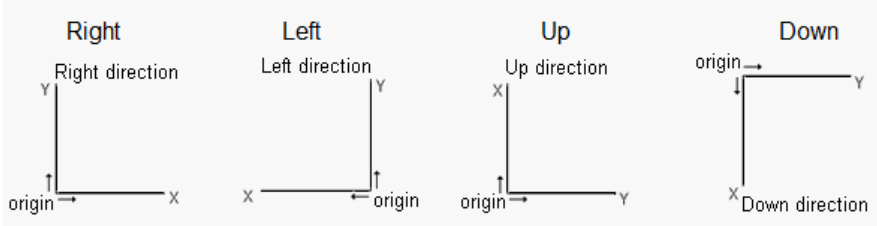
Setting	Description													
Direction	<p>There are four selections, right, left, up or down.</p> 													
No. of channels	Set the number of channels for observation.													
Control address	<p>Controls the operation of all channels simultaneously. When the [Control address] is LW-n, assigning values to LW-n will issue commands to XY plot according to the table below. Meanwhile, LW-n+1 controls the number of data points plotted. After operation, the [Control address] will be reset to 0.</p> <table border="1" data-bbox="488 875 1390 1178"> <thead> <tr> <th>Control address</th> <th>Value</th> <th>Result</th> </tr> </thead> <tbody> <tr> <td rowspan="3">LW-n</td> <td>1</td> <td>Plots point on XY curve. (The plotted points are kept.)</td> </tr> <tr> <td>2</td> <td>Clears all XY curves.</td> </tr> <tr> <td>3</td> <td>Clears then plots new XY curve.</td> </tr> <tr> <td>LW-n+1</td> <td>Any number</td> <td>Controls the number of data points plotted.</td> </tr> </tbody> </table> <p>No. of data address</p> <p>Controls the number of data points. Each channel can plot up to 1023 points.</p>	Control address	Value	Result	LW-n	1	Plots point on XY curve. (The plotted points are kept.)	2	Clears all XY curves.	3	Clears then plots new XY curve.	LW-n+1	Any number	Controls the number of data points plotted.
Control address	Value	Result												
LW-n	1	Plots point on XY curve. (The plotted points are kept.)												
	2	Clears all XY curves.												
	3	Clears then plots new XY curve.												
LW-n+1	Any number	Controls the number of data points plotted.												
Channel	Select a channel to configure.													
Read Address	<p>Device</p> <p>Select a PLC which will be the source of [X data] and [Y data] and designate a read address.</p> <p>The format of the data register blocks used for the display channels depends on whether [Separated address for X and Y data] and/or [Dynamic limits] has been selected. See Example 1.</p>													
Dynamic limits	<ul style="list-style-type: none"> When not selected (See Example 2) <p>The Low and High limits can be set by entering constants. The Low and High limits are used for calculating X and Y range in percentage.</p> <ul style="list-style-type: none"> When selected (See Example 3) <p>A zoom effect can be created by changing the Low / High Limits.</p>													

Example 1

The format of the data register blocks used for the display channels depends on whether [Separated address for X and Y data] has been selected, and if [Dynamic limits] has been selected. The following explains the situations where 16-bit register is used:

- If [Separated address for X and Y data] is **not** selected, and set [Read address] to LW-n:

	Select [Dynamic limits]		Not select [Dynamic limits]	
	X data	Y data	X data	Y data
Low Limit	LW-n	LW-n+2	Constant	Constant
High Limit	LW-n+1	LW-n+3	Constant	Constant
1 st data	LW-n+4	LW-n+5	LW-n+0	LW-n+1
2 nd data	LW-n+6	LW-n+7	LW-n+2	LW-n+3
3 rd data	LW-n+8	LW-n+9	LW-n+4	LW-n+5
4 th data	LW-n+10	LW-n+11	LW-n+6	LW-n+7

- If [Separated address for X and Y data] is selected, and set [X data] to LW-m, [Y data] to LW-n:

	Select [Dynamic limits]		Not select [Dynamic limits]	
	X data	Y data	X data	Y data
Low Limit	LW-m+0	LW-n+0	Constant	Constant
High Limit	LW-m+1	LW-n+1	Constant	Constant
1 st data	LW-m+2	LW-n+2	LW-m+0	LW-n+0
2 nd data	LW-m+3	LW-n+3	LW-m+1	LW-n+1
3 rd data	LW-m+4	LW-n+4	LW-m+2	LW-n+2
4 th data	LW-m+5	LW-n+5	LW-m+3	LW-n+3

Example 2

When [Dynamic limits] is not selected, the Low and High limits can be set. The Low and High limits are used for calculating X and Y range in percentage.

$$\text{Scale (\%)} = \frac{\text{Read Address Value} - \text{Low Limit}}{\text{High Limit} - \text{Low Limit}}$$

If [Separated address for X and Y data] is **not** selected and the address is LW-n, the corresponding limits are retrieved from the addresses as shown in the following table.

Data format	16-bit	32-bit	64-bit (cMT / cMT X only)
X axis low limit	LW-n	LW-n	LW-n
X axis high limit	LW-n+1	LW-n+2	LW-n+4
Y axis low limit	LW-n+2	LW-n+4	LW-n+8
Y axis high limit	LW-n+3	LW-n+6	LW-n+12

Example 3

If **[Dynamic limits]** is selected, a zoom effect can be created by changing the setting of Low / High Limits.

In the following example, XL=X low limit, XH=X high limit, YL=Y low limit, YH=Y high limit, and XY, XY1, XY2 are three XY data. When changing the high limits of X and Y axis, the result is shown below:

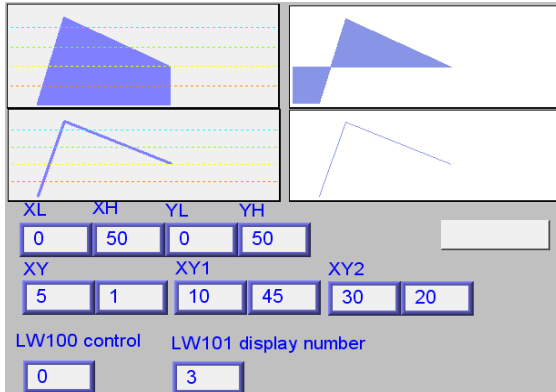

Original

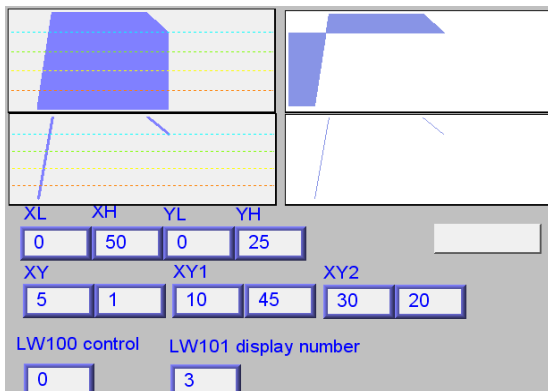

Change the high limit of Y axis to 25.
(zoom in)

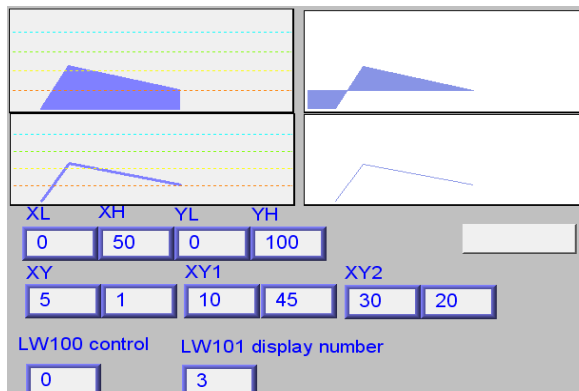

Change the high limit of Y axis to 100 (zoom out)

For more information, see “13.17 Trend Display”.

Note

- X and Y data can be set to different formats. For example: If X data uses 16-bit unsigned, Y data uses 32-bit signed, please note the address setting.
- When using a Tag PLC, such as AB tag PLC, X and Y must be in the same format. When using different formats a warning will be shown.

Display Area Tab

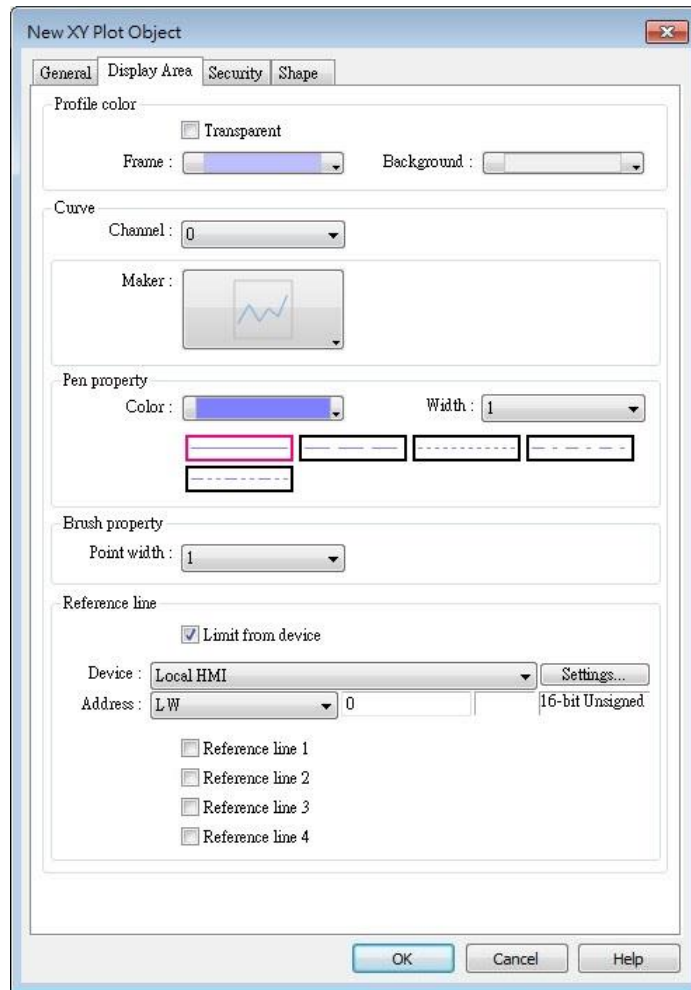

Setting	Description
Profile color	Select the color of the frame and the background, or select [Transparent] check box to hide the frame and background.
Curve	For each channel select the properties of color, width, and line style.
Maker	Select the style of XY Plot. For eMT/iE/XE/mTV series, there are four different types of XY plot as shown below:

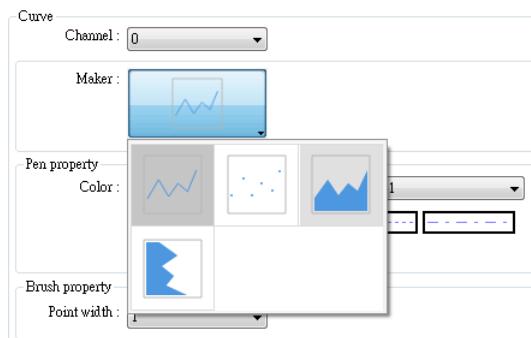

For cMT / cMT X Series, , there are six different types of XY plot as shown below:



See Example 4.

Pen property	Select color, width and style for the line in XY plot.
Brush property	Select point width.
Reference line	Up to 4 horizontal reference lines can be shown on the graph. Fill in high, low limits and Y axis percentage values. Different colors can be selected for each reference line. If [Limit from PLC] is selected, designate a register to be the read address of reference line.

Example 4

The curve shown in the following figure is drawn with 7 points numbered from P0 to P6.

The steps the system draws the X-axis Projection are:

1. Calculates the two points in X-axis – $(X_0, 0)$ and $(X_6, 0)$.
2. Link all the points in the order of $(X_0, 0)$, P0... P6, $(X_6, 0)$ and returns to $(X_0, 0)$ at last.
3. Fill out all enclosed areas.

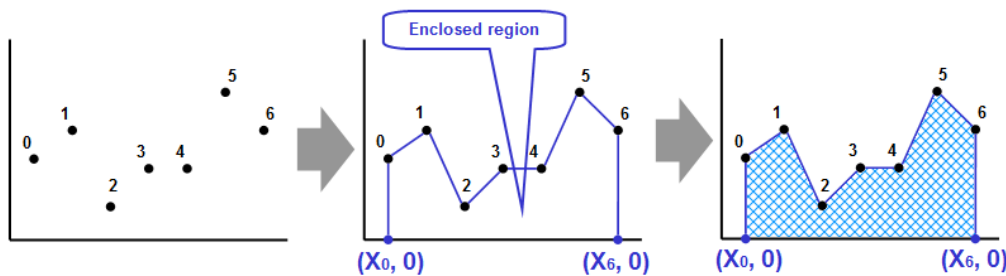

Similarly for Y-axis projection:

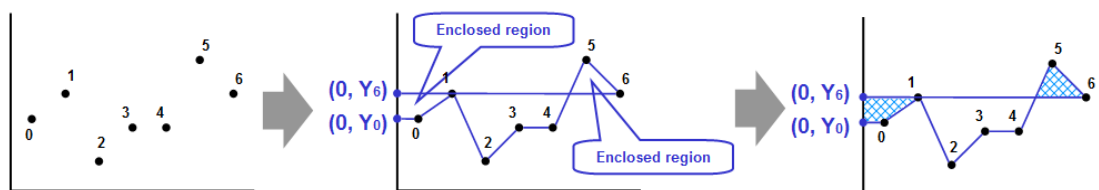

 **Note**

- Without clearing the drawn points, XY Plot can be drawn a number of times by entering value 1 in the control address repeatedly. The way to calculate the maximum number of times is: 32 divided by the number of channels.
 - 1 channel → 32 times
 - 2 channels → 16 times
 - 16 channels → 2 times

13.21. Alarm Bar and Alarm Display

13.21.1. Overview

Alarm Bar and Alarm Display objects are used to display alarm messages which are defined in Event (Alarm) Log objects. When the trigger conditions are met, events or alarms will be displayed as they occur in chronological order in Alarm Bar or Alarm Display object.

Alarm Bar scrolls all alarm messages in one single display line, whereas Alarm Display shows alarm messages in multiple lines.

 For more information, see “7 Event Log”.

! (When LW 1 >= 10) 13:21:06 Event 0 (when LW0

Alarm Bar - Displays alarm messages in one scrolling line.

***13/12/06 13:21:38 Event 2 (when LB10 = ON)
13/12/06 13:21:38 Event 3 (when LB11 = ON)
13/12/06 13:21:38 Event 0 (when LW0 == 100)
13/12/06 13:21:38 Event 1 (When LW 1 >= 10)***

Alarm Display – Displays alarm messages in multiple lines.

13.21.2. Configuration



Click [Data/History] » [Alarm Display] or [Alarm Bar] icon on the toolbar to open the object property dialog box. Set up the properties, press OK button, and a new object will be created.

General Tab

The difference between these two objects is that Alarm Display allows an [Acknowledge address] and a [Scrolling control address] to be set.

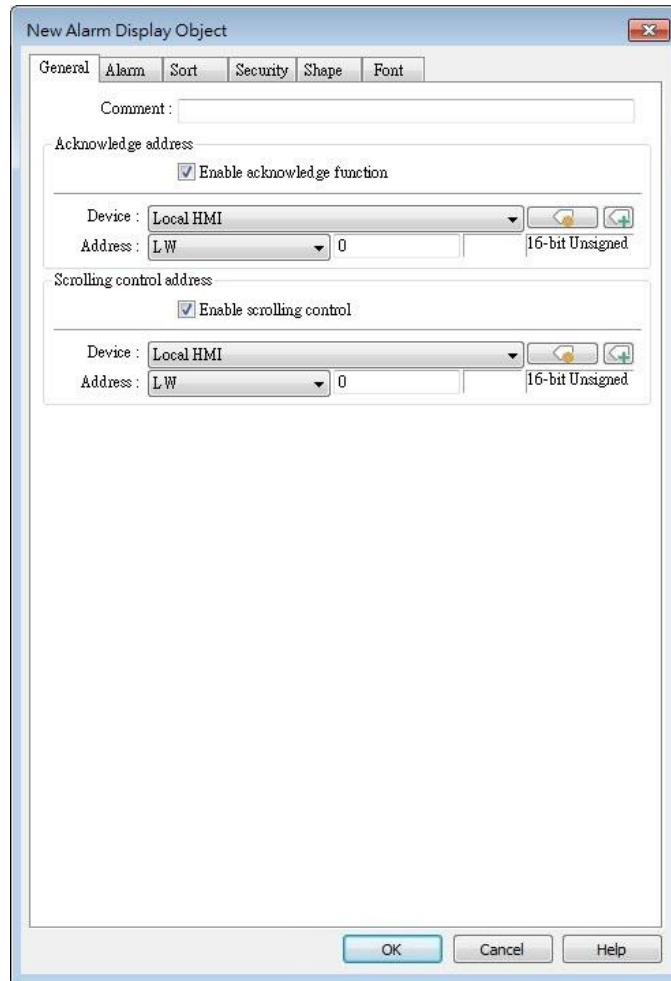

Setting	Description
Enable acknowledge function	If selected, the [Acknowledge value] selected for the associated event, specified in Alarm (Event) Log » Message tab will be written to the [Acknowledge address] designated in Alarm Display. For more information, see “7 Event Log”.
Scrolling control address	If enabled, the value in the designated control address indicates the number of lines to be scrolled down. The minimal value is 0, which indicates the first line. Please note that with this address enabled, the horizontal and vertical scroll bars will not be available on the object; please make sure that the width of the object is enough for completely showing the content.

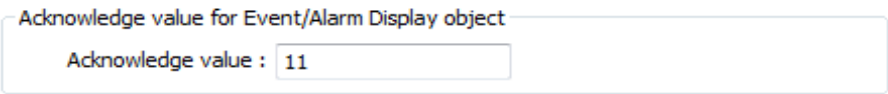

 **Note**

- When using a cMT / cMT X Series model, press and hold the event on the screen to

acknowledge an event; drag a finger on the screen to scroll.

- When using a cMT / cMT X Series model, a default minimal row height exists in Alarm Display objects that have enabled Acknowledge function. The minimal row height prevents the rows to be touch by mistake. On a small-sized HMI, the row height may be slightly taller when Acknowledge function is enabled.

Alarm Tab

Alarm Bar

Alarm Display

Setting

Description

Display

Display settings are only available for Alarm Bar.

iP/iE/XE/eMT/mTV Series

Display _____

Speed : Speed 5 ▾

Move smoothly (may lead to higher CPU usage)

When [Move smoothly] option is selected, the message will move along the Alarm Bar object more smoothly. Please note that enabling this may lead to high CPU loading.

cMT / cMT X Series

The available modes are [Carousel] and [Marquee].

Display _____

Mode : ▾

Interval : ▾ second(s)

Show current and total number of alarm

Display _____

Mode : ▾ ⓘ

Speed : ▾

Multi-line display

When [Carousel] mode is selected, the option to display the current and total alarm count and set the interval in seconds can be enabled.

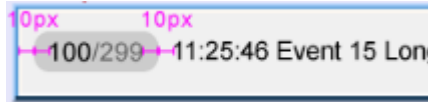

When [Marquee] mode is selected, the speed of text movement in the Alarm Bar object can be adjusted. Enabling multi-line display allows the event content to be shown in multiple lines within the Alarm Bar object. Please consider the performance impact when using this mode.

Include categories

Events in the selected category will be displayed. The categories are set in Event (Alarm) Log object.

For example, if the category is set to “2 to 4” here, only events in categories 2, 3, 4 will be displayed. For more information, see “7 Event Log”.

cMT / cMT X Series

Dynamic Category Range is an option available only for cMT Series models. With this option selected, an address can be designated for dynamically selecting event categories to be displayed.

Include categories: _____

Predefined Dynamic category range

Device : ▾

Address : ▾

Range begin : LW-0

Range end : LW-1

Caption

Caption settings are only available for Alarm Display on cMT / cMT X Series.

Caption _____

Use caption

Font size : 16 Color : _____

Name	
Caption	Caption

Option button visibility (cMT / cMT X Series)

Show or hide the option button .



Predefined

Select [Enable] to show the option button.

Dynamic

Option button visibility

Predefined Dynamic

Device : Local HMI  

Address : LB 0

Designate a bit address to control option button visibility.

Sort Tab

Alarm Bar

New Alarm Bar Object

Alarm Sort Security Shape Font

Format

Sort

Order : Time ascending

Order & Characters

Display items	Display order
<input type="checkbox"/> Trigger date	Trigger time
<input checked="" type="checkbox"/> Trigger time	Message
<input checked="" type="checkbox"/> Message	

Date : MM/DD/YYYY Time : HH:MM:SS

OK Cancel Help

Alarm Display

New Alarm Display Object

General Alarm Sort Title Security Shape Font

Format

Sort

Order : Ascending Sort by : Priority level

Order & Characters

Display items	Display ch...	Display order
<input type="checkbox"/> Trigger date	0	Trigger time
<input checked="" type="checkbox"/> Trigger time	0	Message
<input checked="" type="checkbox"/> Message	20	
<input type="checkbox"/> Occurrence count	0	
<input type="checkbox"/> Elapsed time	0	
<input type="checkbox"/> Priority level	0	
<input type="checkbox"/> Category	10	
<input type="checkbox"/> Subcategory 1	10	

* Each column width is determined by: "Display chars" * (width of the character 'x')

* Set "Display chars" to 0 to autofit column width to the contents. (Exception: Event message)

Date : MM/DD/YYYY Time : HH:MM:SS

OK Cancel Help

Setting

Order (Alarm Bar)

Description

Time ascending
Latest event is placed last in the list (the bottom).

	<p>Time descending Latest event is placed first in the list (the top).</p>
Order (Alarm Display)	<p>Sort by:</p> <p>Ascending – Priority Level (cMT / cMT X Series) Event with highest priority level is placed last in the list (the bottom).</p> <p>Descending – Priority Level (cMT / cMT X Series) Event with highest priority level is placed first in the list (the top).</p> <p>Ascending – Occurrence Count Event with highest occurrence count is placed last in the list (the bottom).</p> <p>Descending – Occurrence Count Event with highest occurrence count is placed first in the list (the top).</p> <p>Ascending - Time Latest event is placed last in the list (the bottom).</p> <p>Descending - Time Latest event is placed first in the list (the top).</p>
Display order	Select the items to be displayed and use the up and down arrow buttons to adjust the display order of the alarms.
Date	<p>Displays the date tag with each alarm message. The four formats of date tag:</p> <p>MM/DD/YY 、 DD/MM/YY 、 DD/MM/YY 、 YY/MM/DD</p>
Time	<p>Displays the time tag with each alarm message. The four formats of time tag:</p> <p>HH:MM:SS 、 HH:MM 、 DD:HH:MM 、 HH</p>

Title Tab

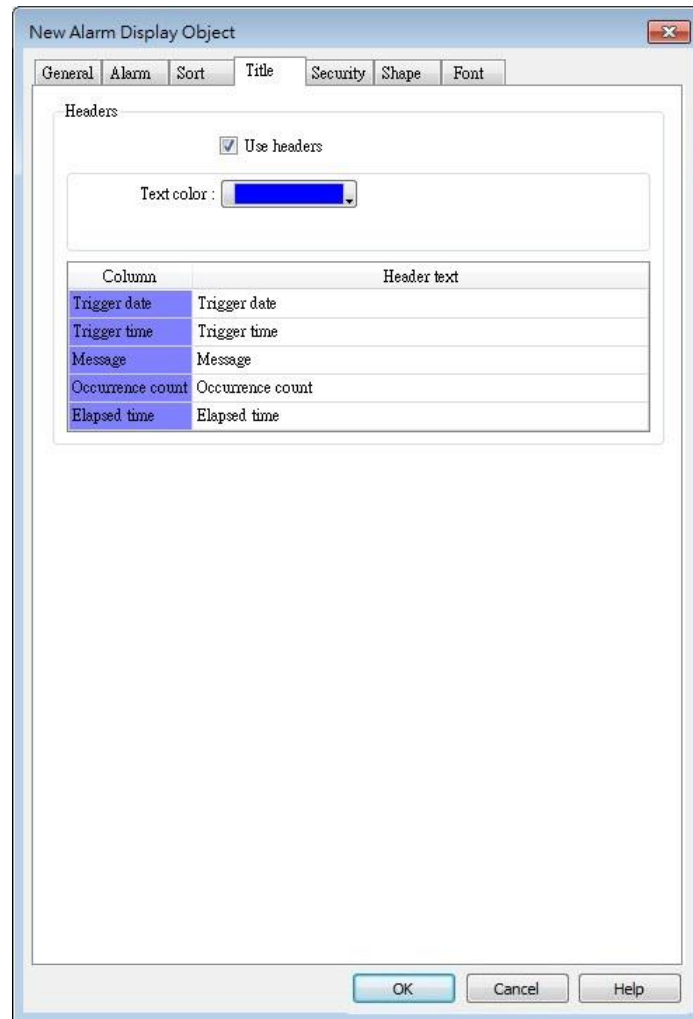

Title settings are available on cMT Series. With [Use headers] selected, the text color and column headers can be configured.

Security Tab

Alarm Bar

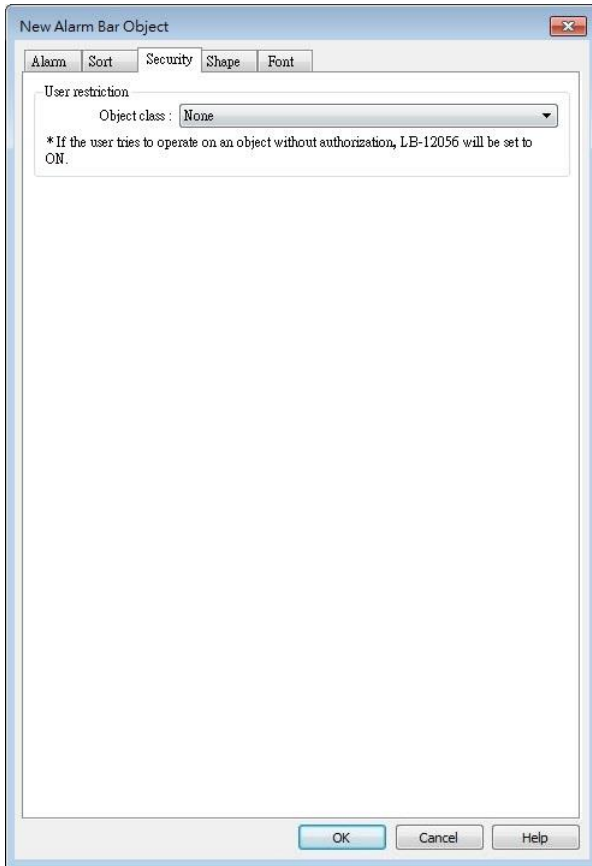

Alarm Display

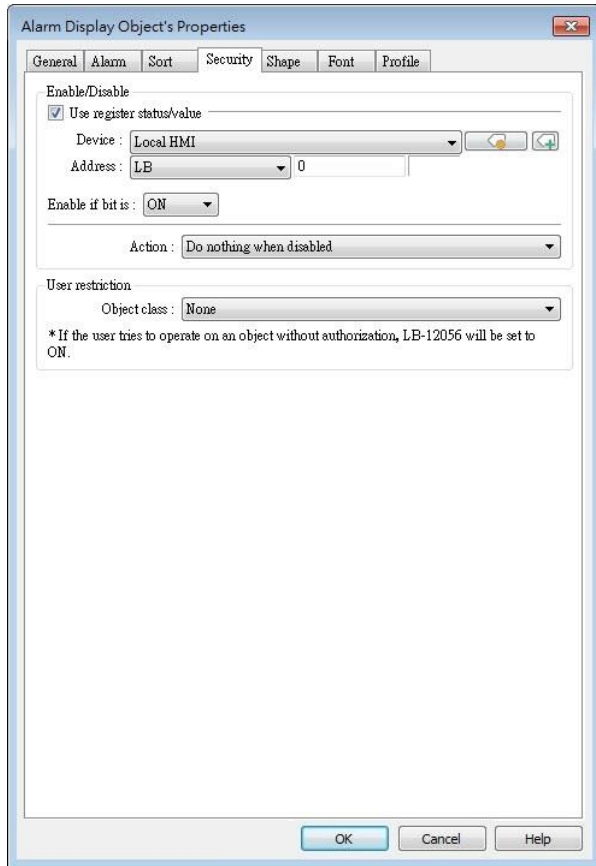

Setting	Description
Interlock	When [Use interlock function] check box is selected, whether the object is operable is determined by the state of a designated Bit address. As shown in the above settings, if LB-0 is ON, the object is operable.
Hide when disabled	When the designated Bit is OFF, the object will be hidden.
User restriction	Set the security class of the object to be operated by an authorized user. Object class "None" means any user can operate this object. Only account "admin" can operate "Administrator" object class. Make invisible while protected When the user's privilege does not match the object class, the object will be hidden. When this check box is deselected in Alarm Display

object settings, the unauthorized user can see the Alarm Display object, but cannot trigger the object or make any change.

This check box is greyed out in Alarm Bar object settings.

Font Tab

Set the font size or select [Italic].

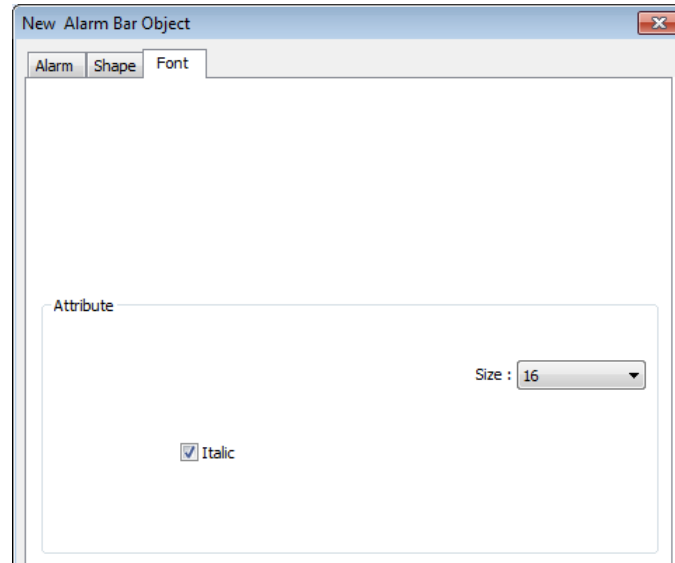

The font, color, and content of the alarm messages displayed in Alarm Bar and Alarm Display objects are set in Alarm (Event) Log object:

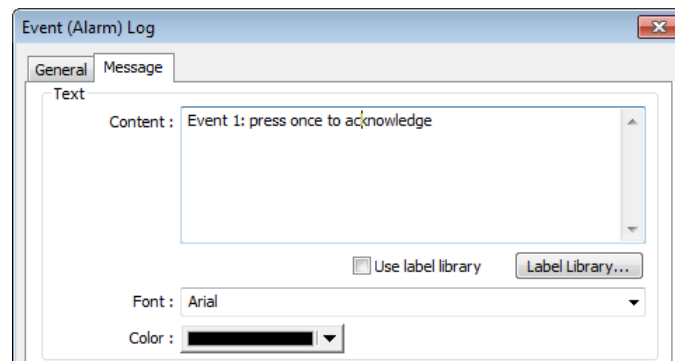

13.22. Event Display

13.22.1. Overview

The Event Display object displays events from the Event (Alarm) Log that meet the specified trigger conditions. These displayed events can be sorted based on time, occurrence count, or priority level. The Event Display object provides information about the events, including the trigger date / time, acknowledge time, recovered time, message, occurrence count, elapsed time, priority level, category, and subcategory. Furthermore, it is capable of displaying multi-lined messages as well.

8	12/13/06	22:03:15		Event 3 (when LB11 = ON)
7	12/13/06	22:03:14	22:03:17	Event 2 (when LB10 = ON)
6	12/13/06	22:03:13		Event 1 (When LW 1 >= 10)
5	12/13/06	22:03:12		Event 0 (when LW0 == 100)
4	12/13/06	22:02:57		Event 3 (when LB11 = ON)
3	12/13/06	22:02:56	22:03:04	Event 2 (when LB10 = ON)
2	12/13/06	22:02:56	22:02:58	Event 1 (When LW 1 >= 10)

1	07/27/10	14:32:56	14:32:57	14:32:59	Event 0 LW 0 < 2 Multi-text
---	----------	----------	----------	----------	-----------------------------------

Multi-text

13.22.2. Configuration



Click [Data/History] »[Event Display] icon on the toolbar to open an Event Display object property dialog box. Set up the properties, press OK button, and a new Event Display object will be created.

General Tab

13.22.2.1. eMT, iE, XE, mTV Series

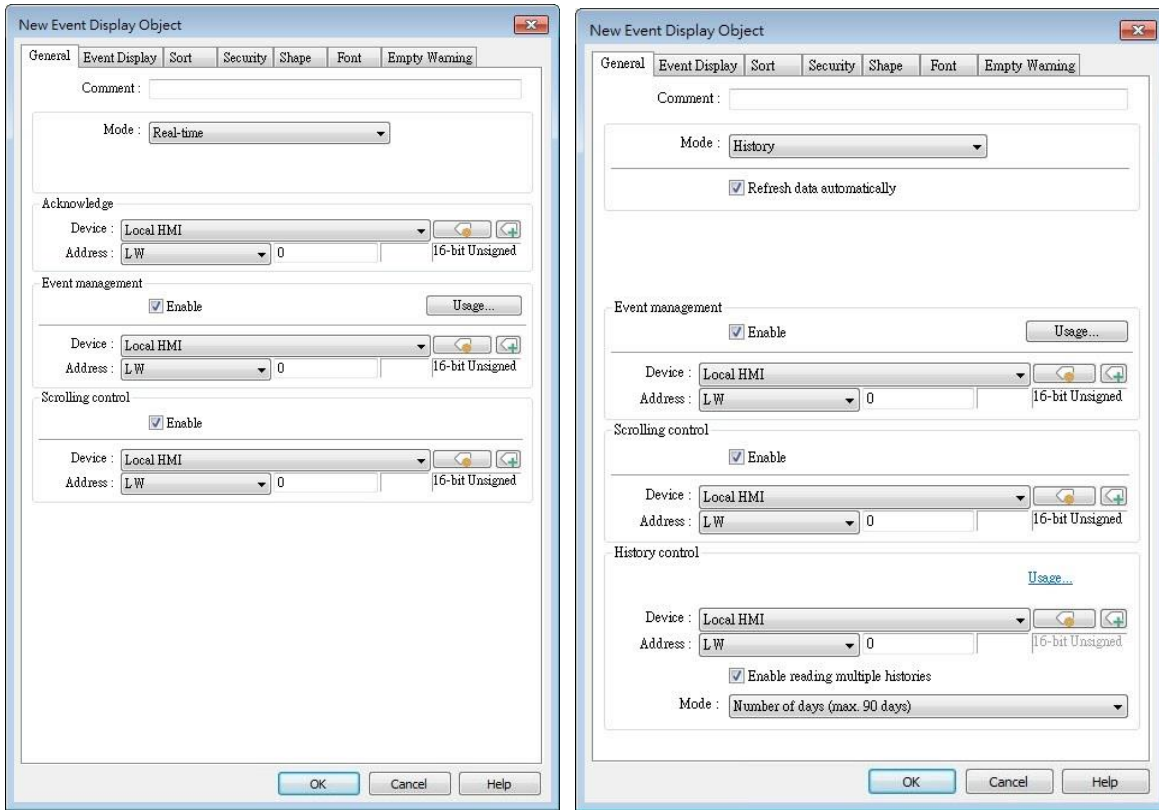

Setting

Description

Mode

The available modes are: [Real-time] and [History].

- Real-time
All the events triggered since HMI starts up are displayed.
- History
The system reads the event log in HMI memory and displays them. The content can be updated by changing window. In case when the trend display shows history data from today, the display will refresh once per second.

Acknowledge

When in Real-time mode and an event is acknowledged by touching an active display line, the [Acknowledge value] specified in Event (Alarm) Log object, Message tab, is output to the [Acknowledge address] of Event Display object. For more information, see “7 Event Log”.

Acknowledge value for Event/Alarm Display object

Acknowledge value : 11

History Control

When in History mode and if:

- [Enable reading multiple histories] is **not** selected

The history files are sorted by date and each file is given an index. The latest one is assigned index 0 (in most cases: today), the second latest file is assigned index 1, and so on. The history control address is used to specify the history file to be displayed.

If control address is LW-100, and four files exist with dates: EL_20100720.evt, EL_20100723.evt, EL_20100727.evt, and EL_20100803.evt.

The index value given to each file is shown below:

Value in LW-100	The corresponding file
0	EL_20100803.evt
1	EL_20100727.evt
2	EL_20100723.evt
3	EL_20100720.evt

- [Enable reading multiple histories] is selected

Displays a list of events triggered in multiple days. The display range is formed by two consecutive addresses. Please note that the history control address is defined differently in “Number of days” mode and in “Index of the last history” mode.





Number of days

Suppose the history control address is set to LW-n, then:

[LW-n]: The start day index (which is expressed as the number of days before today. 0: today, 1: yesterday, and so on.)

[LW-n+1]: The total number of days to display. The days are calculated backward from the start day.

Example: If today were 2010/6/10, and LW-n = 1, LW-n+1 = 3, then the data range will start from 1 day before today, which is 20100609 (yesterday), and include data for 3 days: 20100607~20100609.

 EL_20100604	No.4	1 KB	EVT
 EL_20100605	No.3	6 KB	EVT
 EL_20100608	No.2	17 KB	EVT
 EL_20100609	No.1	4 KB	EVT
 EL_20100610	No.0	12 KB	EVT





Index of the last history

Suppose the history control address is set to LW-n, then:

[LW-n]: The index value of the file to start. 0: the latest file, 1: the second latest file, and so on.

[LW-n+1]: The index value of the file to end. The specified value must be greater than that of the start index.

Example: If LW-n = 1 and LW-n+1 = 3, then file No.1, No.2, No.3 will be displayed.

 EL_20100604	No.4	1 KB	EVT
 EL_20100605	No.3	6 KB	EVT
 EL_20100608	No.2	17 KB	EVT
 EL_20100609	No.1	4 KB	EVT
 EL_20100610	No.0	12 KB	EVT

The maximum size of data that can be displayed is 4MB. Data exceeding the limit will not be displayed.

The following shows how data will be displayed according to data size.
 5 history data, each is 0.5MB → Data displayed: 8 x 0.5MB
 5 history data, each is 1MB → Data displayed: 4 x 1MB
 5 history data, each is 1.5MB → Data displayed:
 2 x 1.5MB+1 x 1MB (partial)

Event management

Enable event management

If this check box is selected, writing a specific value into register LW-n and LW-n+1, where n is an arbitrary number, will control [Event Display] object with different commands as shown below:

Address	Value	Command
LW-n	0	Display all events.
	1	Hide [Confirmed] events.
	2	Hide [Recovered] events.
	3	Hide [Confirmed] or [Recovered] events.
	4	Hide [Confirmed] and [Recovered] events.
LW-n+1	1	In real-time mode, delete a single selected event.

Scrolling control

If enabled, the value in the designated control address indicates the number of lines to be scrolled down. The minimal value is 0, which indicates the first line.

In the following figure, there are 10 events recorded in the object, and value 3 is set at the control address. The upper event object displays the events in time ascending order, and begins at the 4th event; on the other hand, the lower one displays the events in time descending order, and begins at the 7th event.

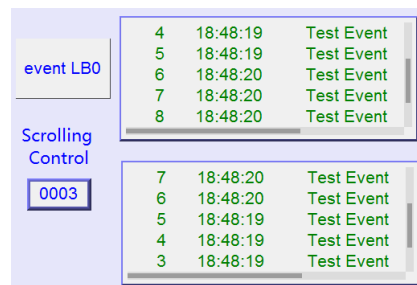

If [Scrolling control address] is enabled, the scroll bar cannot be used for scrolling, but still shows the relative position of the content. If the control address holds a value that is larger than the total number of lines, the display will stroll to the end. Please note that with this address enabled, the horizontal and vertical scroll bars will not be available on the object; please make sure that the width of the object is enough for completely showing the content.

13.22.2.2. cMT, cMT X Series

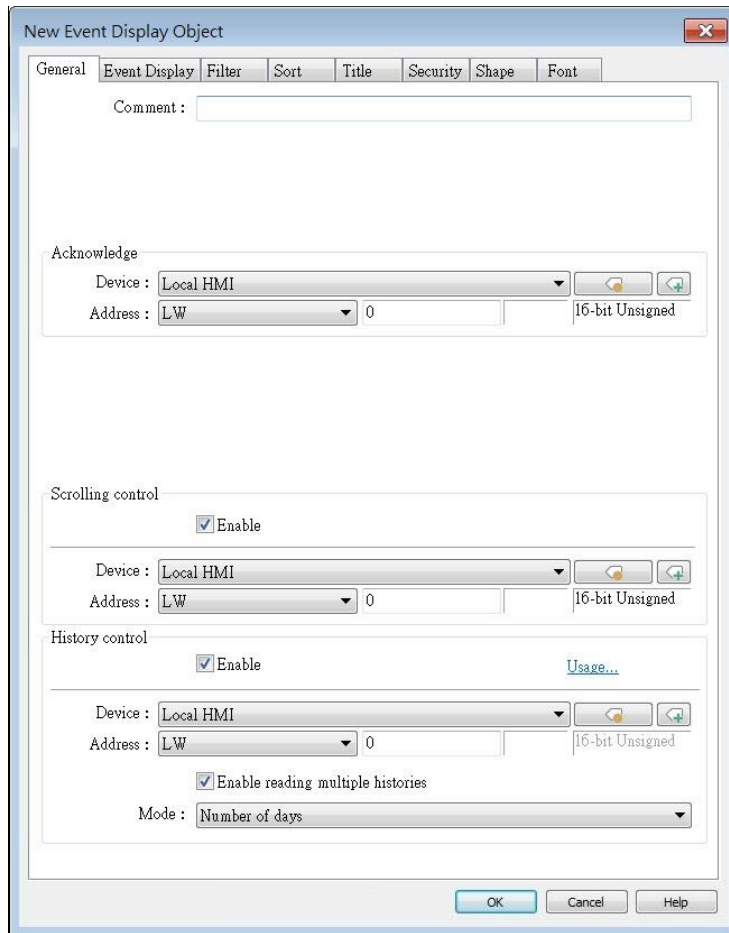

For cMT / cMT X models, only events with “save to history” option selected in the Event (Alarm) Log settings can be displayed in the Event Display object. The events that are not set to be saved in the history can be displayed using the Alarm Bar or Alarm Display object.

Setting	Description
Acknowledge	When an event is acknowledged, the value specified in the Acknowledge Value field under the Message tab of the Event (Alarm) Log settings will be outputted to the Acknowledge address of the Event Display object. For more information, see “7 Event Log”. <div style="border: 1px solid gray; padding: 5px; margin: 5px 0;"> Acknowledge value for Event/Alarm Display object Acknowledge value : 11 </div>
Scrolling control address	If enabled, the value in the designated control address indicates the number of lines to be scrolled down. The minimal value is 0, which indicates the first line.
History Control	<ul style="list-style-type: none"> [Enable reading multiple histories] is not selected The history files are sorted by date and each file is given an index which is expressed as the number of days before today. 0: today, 1: yesterday, and

so on. The history control address is used to specify the history file to be displayed.

- [Enable reading multiple histories] is selected

Displays a list of events triggered in multiple days. The display range is formed by two consecutive addresses. Please note that the history control address is defined differently in “Number of days” mode and in “Specific days” mode.

Number of days

Suppose the history control address is set to LW-n, then:

[LW-n]: The start day index (which is expressed as the number of days before today. 0: today, 1: yesterday, and so on.)

[LW-n+1]: The total number of days to display. The days are calculated backward from the start day.

Specific days

Suppose the history control address is set to LW-n, then:

[LW-n]: The start day index. 0: today, 1: yesterday, and so on.

[LW-n+1]: The end day index. The specified value must be greater than that of the start day index.

Example: When start = 4 and end = 7, the specified days will be 4 days before to 7 days before.

For cMT / cMT X Series, all the events that occurred are displayed and updated in real-time.

Press the Option Button  in the upper-right corner of the object and set the start and end date. If the dates are not set specifically, all the events are displayed.

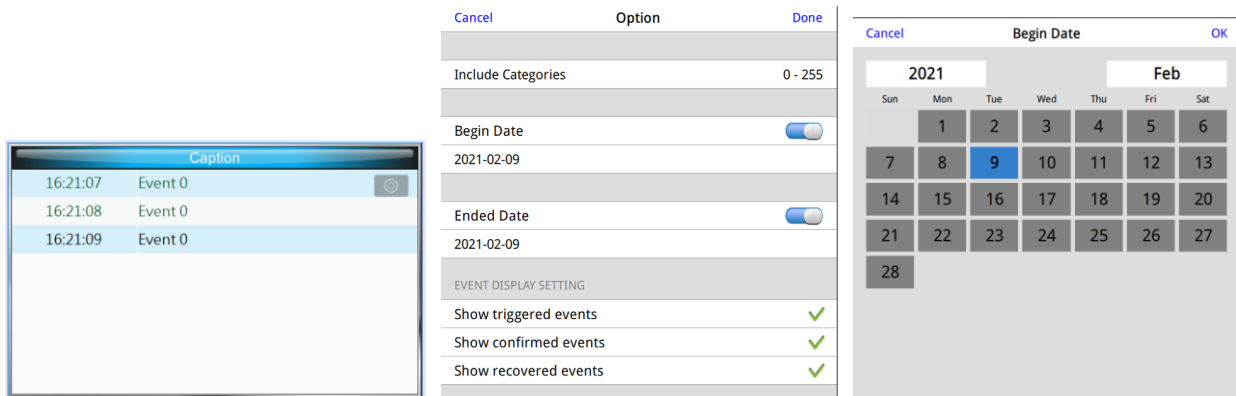

The screenshot shows three overlapping windows from the EasyBuilder Pro software:

- Event List Window (Caption):** Displays a list of events with columns for time and event name.

Time	Event Name
16:21:07	Event 0
16:21:08	Event 0
16:21:09	Event 0
- Option Window:** A settings menu with 'Cancel' and 'Done' buttons. It includes:
 - Include Categories: 0 - 255
 - Begin Date: 2021-02-09 (with a toggle switch)
 - Ended Date: 2021-02-09 (with a toggle switch)
 - EVENT DISPLAY SETTING:
 - Show triggered events:
 - Show confirmed events:
 - Show recovered events:
- Begin Date Calendar Window:** A calendar for February 2021 with 'Cancel' and 'OK' buttons. The date '9' is selected.

Sun	Mon	Tue	Wed	Thu	Fri	Sat
	1	2	3	4	5	6
7	8	9	10	11	12	13
14	15	16	17	18	19	20
21	22	23	24	25	26	27
28						

Event Display Tab

cMT / cMT X Series

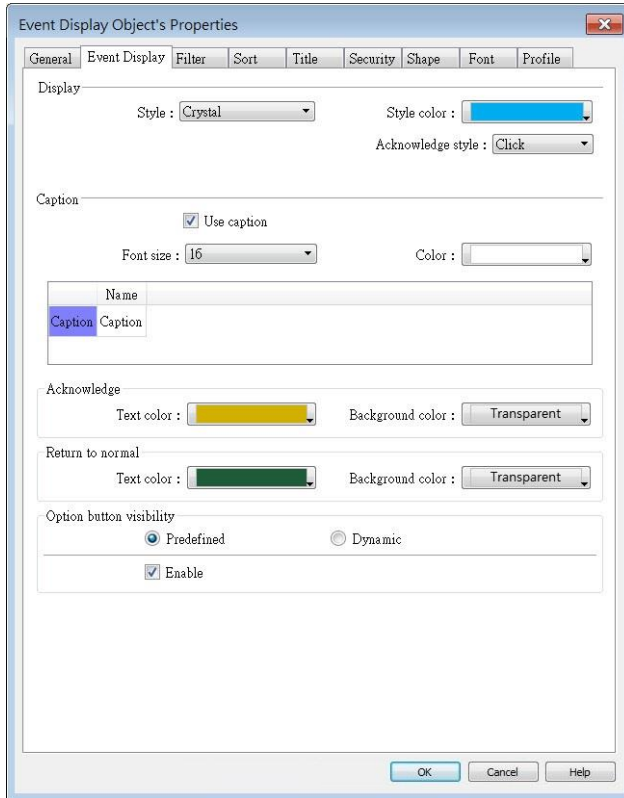

eMT, iE, XE, mTV Series

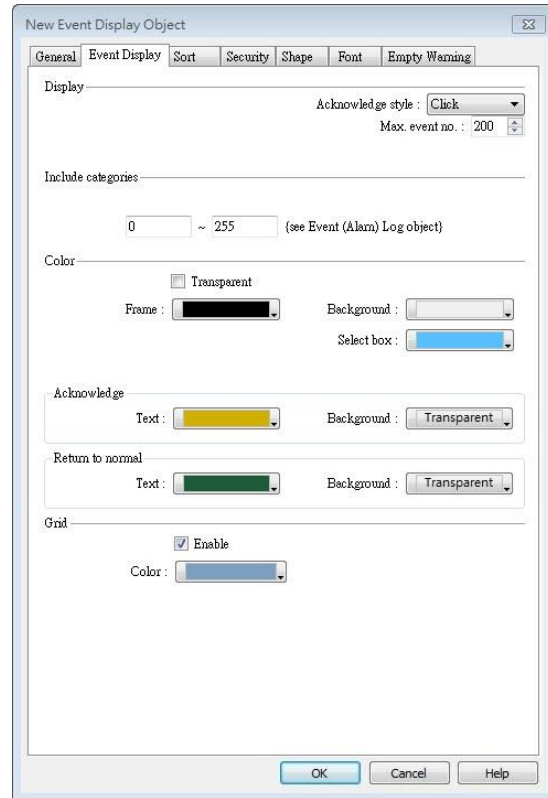

Setting

Description

Include categories

Events in the selected category will be displayed. The categories are set in Event (Alarm) Log object. For example, if the category is set to 2 to 4 here, only events in categories 2, 3, 4 will be displayed. For more information, see “7 Event Log”.

Acknowledge style

Select [Click] or [Double Click] to acknowledge each single event. When an event occurs the user can tap the event line once or twice to acknowledge the new event. When acknowledged, the text color of the event will change to the selected color, and the acknowledge value associated with that event will be sent to the register designated in [Acknowledge address]. If the address is set to LW-100, and the acknowledge value is set to 31, when user acknowledges the event, value 31 is written to LW-100. This can be used in conjunction with Indirect Window object so that when an event is acknowledged, the corresponding message window is displayed.

Max. event no. (eMT, iE, XE, mTV)

The maximum number of events to be displayed in this Event Display object. When the number of the displayed events equals to the set maximum number, the new coming event will overwrite the latest

Series)	event.
Color	Different colors indicate different event states, such as acknowledged, returns to normal, or selected. The system draws a highlight box around the latest selected event.

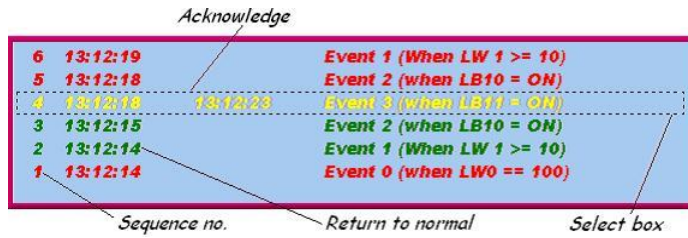

History background (eMT, iE, XE, mTV)

When using Event Display object and select History mode, the background color of the history record can be customized.

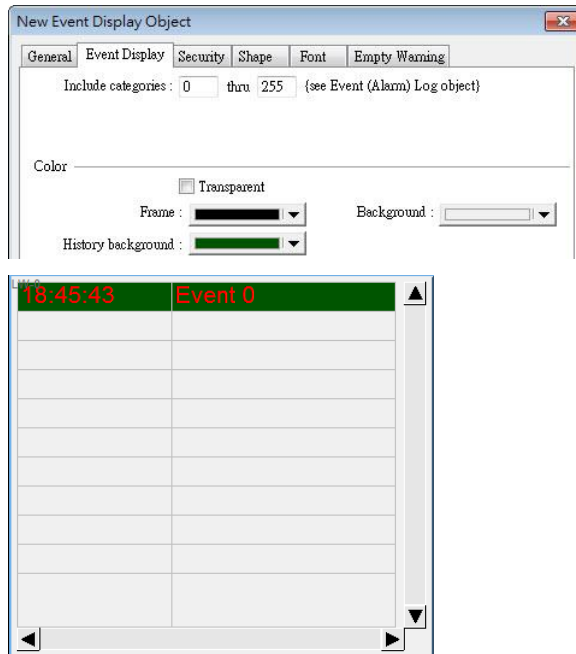

Grid	Displays a grid of rows and columns in the object. The color of the grid lines can be selected. Auto fit short column (cMT / cMT X Series Default style) The column width automatically adjusts to the size of the content.
-------------	--

Caption (cMT / cMT X Series)	Available styles are: Default, Crystal, and Flat. With [Use caption] enabled, the font size, color, and name of the caption can be specified for Recipe View object.
-------------------------------------	---

Option button visibility (cMT / cMT X Series)	Show or hide the option button  . Predefined Select [Enable] to show the option button. Dynamic
--	---

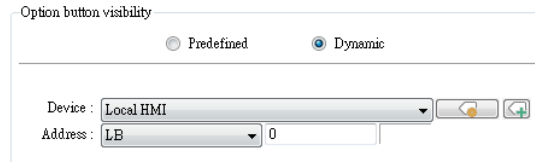

Designate a bit address to control option button visibility.

Filter Tab (cMT / cMT X Series)

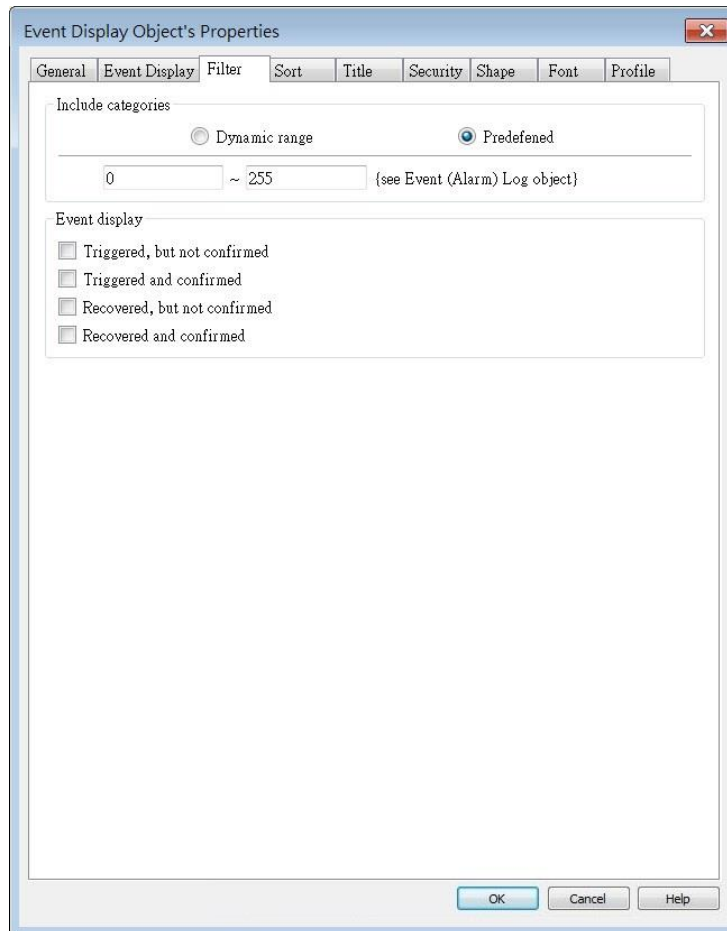

Setting	Description
Include categories	<p>Events in the selected category will be displayed. The categories are set in Event (Alarm) Log object. For example: if the category is set to 2 to 4 here, only events in categories 2, 3, 4 will be displayed. For more information, see “7 Event Log”.</p> <p>When [Dynamic range] is selected, the object can dynamically filter the displayed event categories based on the value in the specified register.</p>

Sort Tab

cMT, cMT X Series

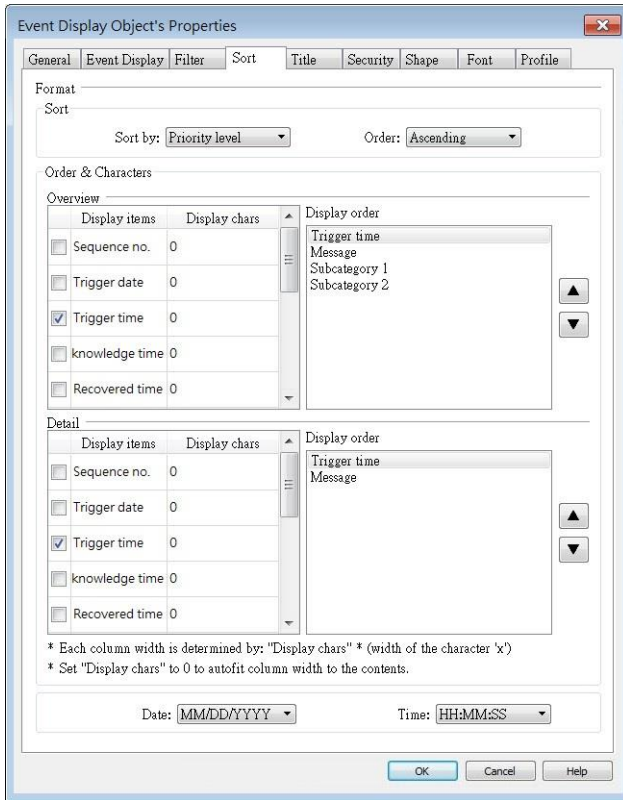

eMT, iE, XE, mTV Series

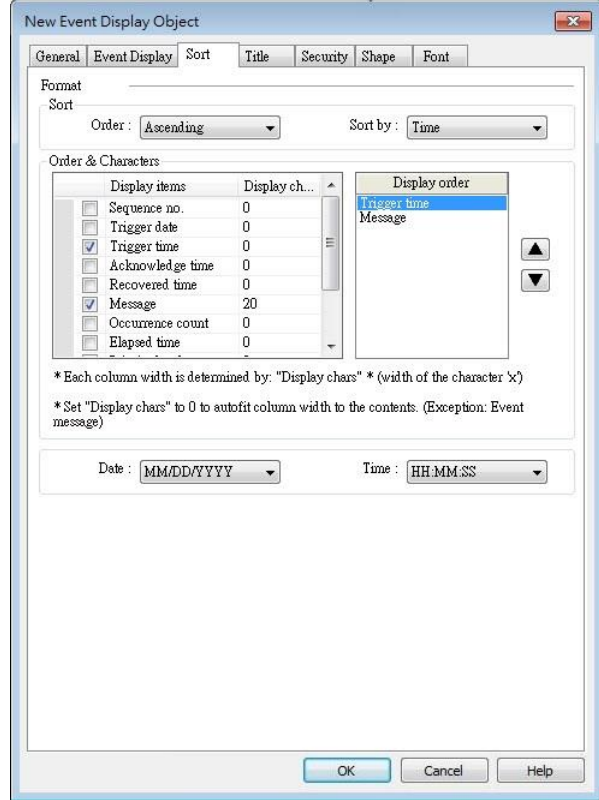

	<i>trigger date</i>	<i>trigger time</i>	<i>notification time</i>	<i>return to normal time</i>	
0	12/14/06	15:26:21	15:26:31	15:26:36	Event 0 (when LV
1	12/14/06	15:26:47	15:26:50		Event 1 (when LV
2	12/14/06	15:26:48			Event 2 (when LE

Setting	Description
Order	<p>Sort by:</p> <p>Ascending – Priority Level (cMT / cMT X Series) Events on the Overview page are grouped and sorted by priority level, with the group of events with highest priority level placed last in the list (the bottom). On the Detail page, all events in the group are displayed in a time descending order, with the latest event placed first in the list (the top).</p> <p>Descending – Priority Level (cMT / cMT X Series) Events on the Overview page are grouped and sorted by priority level, with the group of events with highest priority level placed first in the list (the top). On the Detail page, all events in the group are displayed in a time descending order, with the latest event</p>

placed first in the list (the top).

Ascending – Occurrence Count

eMT, iE, XE, mTV Series: Event with highest occurrence count is placed last in the list (the bottom).

cMT, cMT X Series: On the Overview page, the group of events with the highest occurrence count is placed last in the list (the bottom). On the Detail page, all events in the group are displayed in a time descending order, with the latest event placed first in the list (the top).

Descending – Occurrence Count

eMT, iE, XE, mTV Series: Event with highest occurrence count is placed first in the list (the top).

cMT, cMT X Series: On the Overview page, the group of events with the highest occurrence count is placed first in the list (the top). On the Detail page, all events in the group are displayed in a time descending order, with the latest event placed first in the list (the top).

Ascending - Time

Latest event is placed last in the list (the bottom).

Descending - Time

Latest event is placed first in the list (the top).

Display order	Select the items to be displayed and use the up and down arrow buttons to adjust the display order of the events.
Date	Displays the date tag with each event message. The four formats of date tag: MM/DD/YY 、 DD/MM/YY 、 DD/MM/YY 、 YY/MM/DD
Time	Displays the time tag with each event message. The four formats of time tag: HH:MM:SS 、 HH:MM 、 DD:HH:MM 、 HH

Title Tab

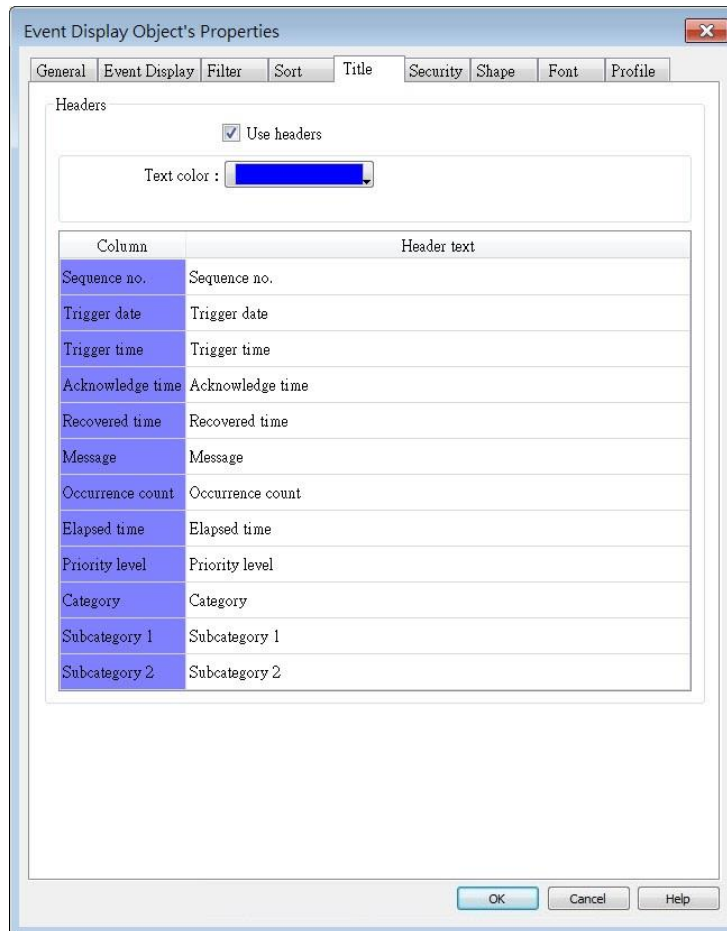

Title settings are available on cMT / cMT X Series. With [Use headers] selected, the text color and column headers can be configured.

Security Tab

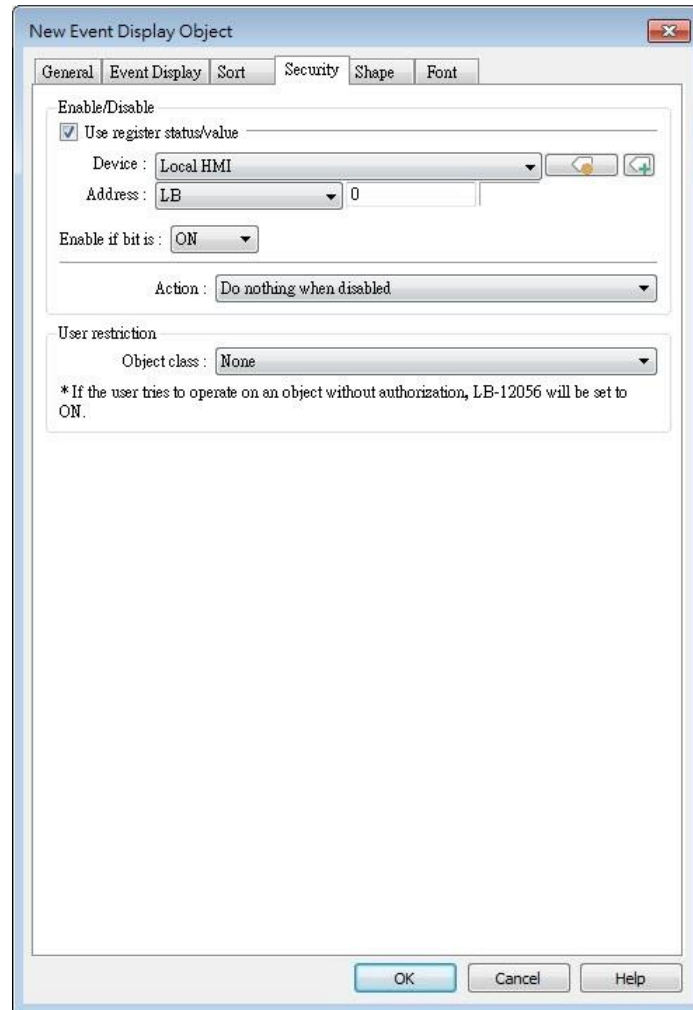

Setting	Description
Interlock	<p>When [Use interlock function] check box is selected, whether the object is operable is determined by the state of a designated Bit address. As shown in the above settings, if LB-0 is ON, the object is operable.</p> <p>Hide when disabled</p> <p>When the designated Bit is OFF, the object will be hidden.</p>
User restriction	<p>Set the security class of the object to be operated by an authorized user.</p> <p>Object class</p> <p>“None” means any user can operate this object. Only account “admin” can operate “Administrator” object class.</p>

Make invisible while protected

When the user's privilege does not match the object class, the object will be hidden.

When this check box is deselected, the unauthorized user can see the Event Display object, but cannot trigger the object or make any change.

Font Tab

In Real-time mode: Users may select Italic font and set the font size. The font is displayed according to the setting in Event Log object.

In History mode: Users may select Italic font and set the font size, font and color, or tick the [Font from label library] check box.



Empty Warning

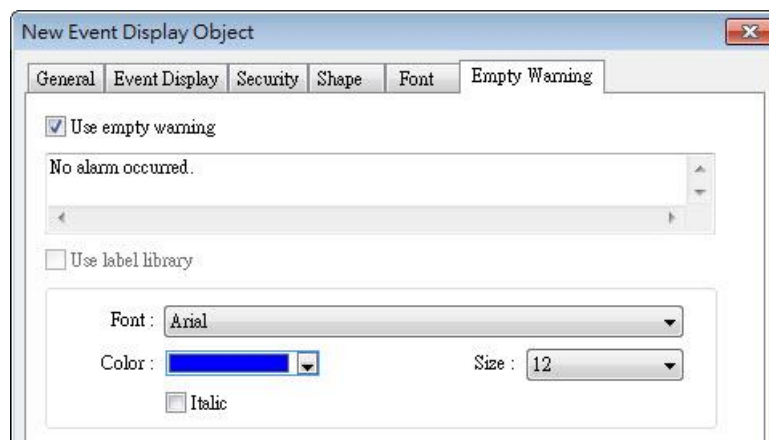

When [Use empty warning] is enabled, the text displayed when no event has occurred can be specified. This feature is not supported on cMT / cMT X Series models.

13.23. Data Transfer

13.23.1. Data Transfer (Per-page)

13.23.1.1. Overview

Data Transfer (Per-page) object can transfer values from the source address to the destination address when the window in which this object is placed opens. The data transfer operation can be activated by manually pressing the object or by detecting the change of state of the designated bit.



- When Data Transfer (Per-page) object in Bit-Trigger mode is placed in the common window, it activates data transfer operation once the specified condition is met, regardless of the current base window.

13.23.1.2. Configuration



Click [Object] » [Data Transfer] » [Data Transfer (Per-page)] icon on the toolbar to open the property dialog box. Set up the properties, press OK button, and a new Data Transfer (Per-page) object will be created.

General Tab

New Data Transfer (Per-page)

General | Security | Shape | Label

Comment : _____

Attribute

Mode : Touch trigger

Activate after button is released

No. of word : 1

Source

Device : Local HMI

Address : LW 0

Destination

Device : Local HMI

Address : LW 0

Notification

Enable Set ON Set OFF

Follow (set ON when data transfer finished)

Device : Local HMI

Address : LB 0

OK Cancel Help

Setting	Description
Source address	Data Transfer object reads the data from [Source Address].
Destination address	Data Transfer object writes the data to [Destination Address].
Attribute	<p>No. of word Enter the number of words to be transferred. Unit: word.</p> <p>Mode Touch trigger Press the object to activate data transfer operation. External trigger The data transfer operation is activated when the state of the designated bit address changes. There is a further selection to make of whether the data transfer operation is activated after OFF to ON, ON to OFF transition, or at both of the changes of state.</p>

Trigger address	Specify a bit address for [External trigger] mode.
Notification	When enabled, the system will set the designated address ON or OFF when it's ready for data transfer. Follow The notification bit will reset to its original state once the system finishes data transfer.

13.23.2. Data Transfer (Global): Time-based

13.23.2.1. Overview

Data Transfer (Global) object in Time-based mode can transfer data from the source address to the destination address based on a time schedule.

13.23.2.2. Configuration



Click [Object] » [Data Transfer] » [Data Transfer (Global)] icon on the toolbar and open the Time-based tab. Click [New] and set up the properties, press OK button, and a new Data Transfer (Global) object will be created. Please note that the data should be imported / exported separately in Time-based mode and Bit Trigger mode of Data Transfer (Global).

cMT / cMT X Series

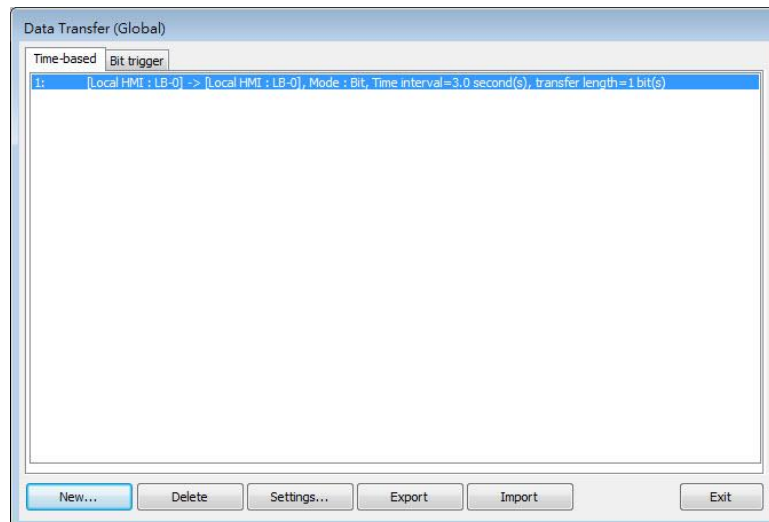

eMT, iE, XE, mTV Series

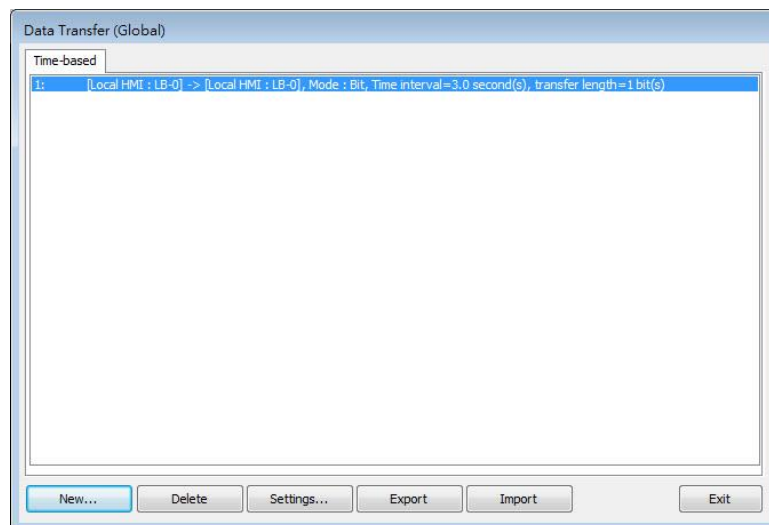

General Tab

Click the [New] button in the Data Transfer management dialog box.

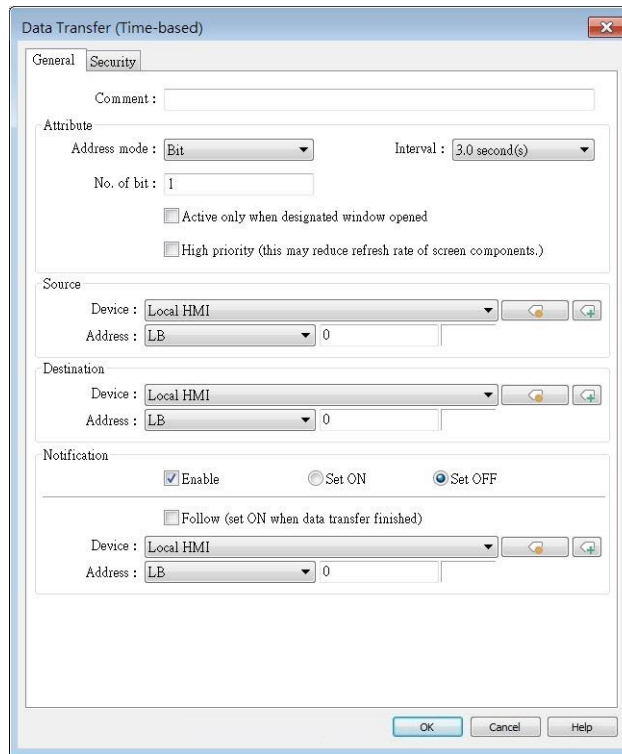

Setting	Description
Attribute	<p>Address mode Select the data type to be transferred from [Bit] or [Word].</p> <p>No. of bit /No. of word When [Bit] is selected in [Address mode], set the number of bits transferred each time when data transfer is triggered. When [Word] is selected in [Address mode], set the number of words transferred each time when data transfer is triggered.</p> <p>Interval Select the time interval of data transfer; for example, when 3 seconds is set, the system will transfer data every 3 seconds. Specifying a shorter time interval or a greater amount of data to transfer may decrease overall system performance; therefore, a longer time interval or a smaller amount of data to transfer is recommended. When a short interval is inevitable, please at least set an interval longer than the time needed for data transfer operation; for example, when the data transfer operation takes 2 seconds, the interval must be longer than 2 seconds.</p>

Activate only when designated window opened

Data Transfer object transfers data only when the designated window is opened.

High priority

Assign a higher priority level for this data transfer. Please note that this could result in a reduced screen refresh rate.

**Source
address**

Data Transfer object reads the data from [Source Address].

**Destination
address**

Data Transfer object writes the data to [Destination Address].

Notification

When enabled, the system will set the designated address ON or OFF when it's ready for data transfer.

Follow

The notification bit will reset to its original state once the system finishes data transfer.

13.23.3. Data Transfer (Global): Bit Trigger

13.23.3.1. Overview

Data Transfer (Global) object in Bit Trigger mode transfers data from the source address to the destination address when HMI detects that the state of the designated bit address changes. This feature is not supported on eMT, iE, XE, mTV models.

13.23.3.2. Operation



Click [Object] » [Data Transfer] » [Data Transfer (Global)] icon on the toolbar and open the Bit Trigger tab. Click [New] and set up the properties, press OK button, and a new Data Transfer (Global) object will be created. Please note that the data should be imported / exported separately in Time-based mode and Bit Trigger mode of Data Transfer (Global).

General Tab

Setting	Description
Attribute	Trigger mode Trigger data transfer when the state of the designated register changes from OFF to ON, ON to OFF, or at both of the changes of state.
	No. of word Set the number of words transferred each time when data transfer is triggered.

	High priority Assign a higher priority level for this data transfer. Please note that this could result in a reduced screen refresh rate.
Source address	Data Transfer object reads the data from [Source Address].
Destination address	Data Transfer object writes the data to [Destination Address].
Trigger address	Set the address used to control data transfer and select the trigger mode.
Notification	When enabled, the system will set the designated address ON or OFF when it's ready for data transfer. Follow The notification bit will reset to its original state once the system finishes data transfer.

13.24. Backup

13.24.1. Overview

Backup (Trigger-based) object and Backup (Global) object can transmit recipe data (RW, RW_A), event log, recipe database, sampling data, and operation log to an external device (SD card, USB disk), in a specified time range or format. For example, when the event log is saved in a SD card, a USB disk can be inserted when HMI power is still ON, and use Backup object to copy the data into USB disk from SD card, and then remove USB disk without turning off HMI power. The data saved in USB disk can be used on PC for analyzing. When the system is backing up, the state of system register [LB-9039] is set ON. With [e-Mail] option, information can be sent to configured email contacts.

Backup (Trigger-based) object is triggered by pressing the object on the screen while Backup (Global) object runs in the background regardless of screens being viewed. Backup (Global) object is available only on cMT / cMT X Series models.

13.24.2. Configuration



On the toolbar click [Object] » [File Operation] to find [Backup (Trigger-based)] and [Backup (Global)] objects.

Open [Backup (Trigger-based)] object property dialog box, set up the properties, press OK button, and a new Backup (Trigger-based) object will be created.

When using a cMT / cMT X Series model, [Backup (Global)] object is available. Open [Backup (Global)] object managing dialog box, click [New] to open the object property dialog box, set up the properties, press OK button, and a new Backup (Global) object will be created.

General Tab

Backup (Trigger-based)

cMT / cMT X Series

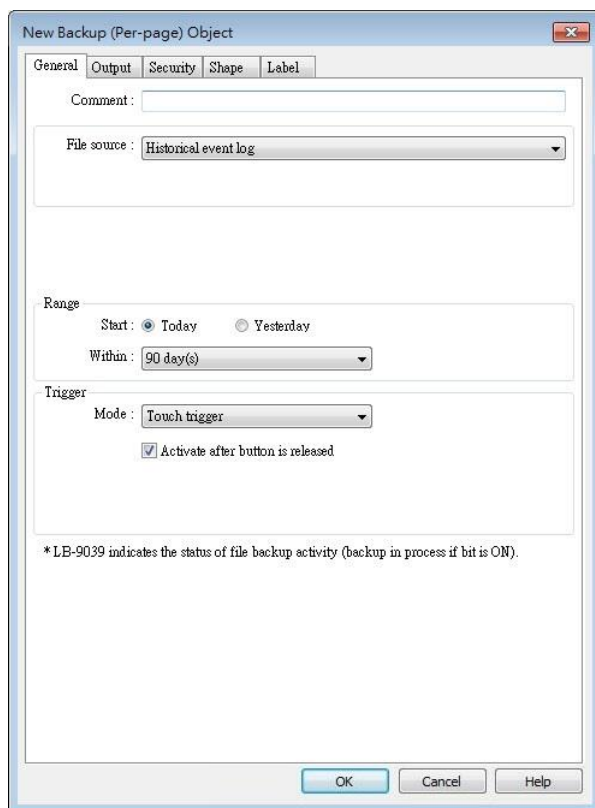

eMT, iE, XE, mTV Series

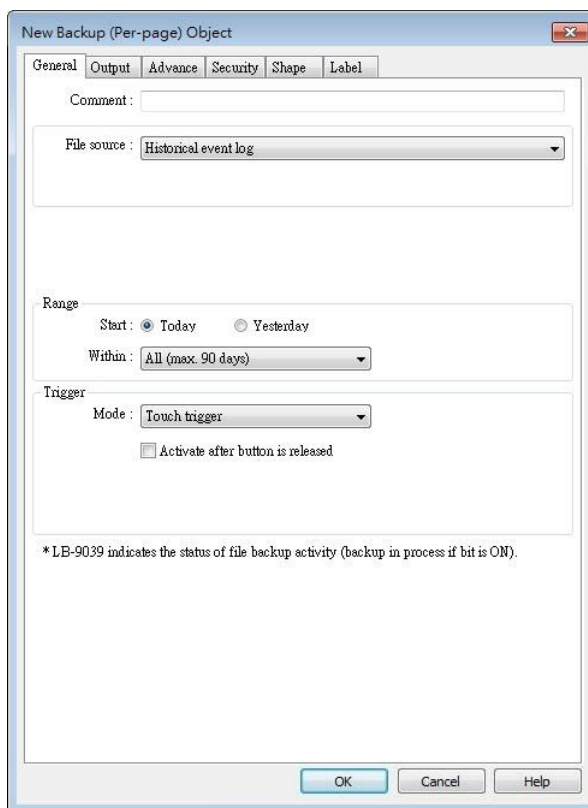

Backup (Global) cMT / cMT X Series

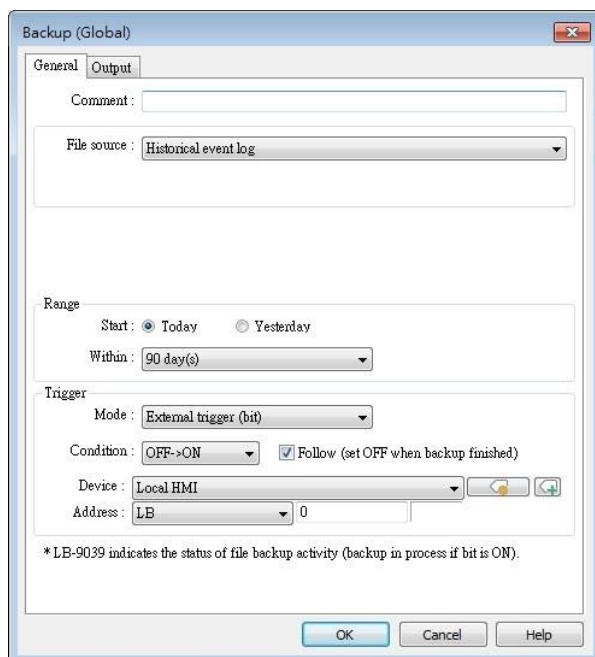

Setting	Description
Source	[RW], [RW_A], [Recipe database], [Historical event log],

[Historical data sampling], [Operation log], [SQL Query]

Select one from the above for the source. When backing up [Historical data sampling], use [Data Sampling object index] to select the one to back up.

Options other than RW, RW_A will be available only when they are used in the project file.

Event category range

This groupbox will be available only when backing up a historical event log in CSV format. Two options can be found in this group box: All and Partial. Selecting partial and entering "3, 5, 8" in the field will backup events in categories 3, 5, and 8. Selecting partial and entering "3-8" will backup events in categories 3 to 8.

Range**Historical data sampling**

Select a number of files. For example, if [Start] is set to [Current], and [Within] is set to [5 file(s)], the latest five files in memory will be backed up.

Historical eventlog

Select a number of days. For example, if [Start] is set to [Yesterday], and [Within] is set to [2 day(s)], the files obtained yesterday and the day before yesterday will be backed up. Select [All] to save all files, and the maximum is 90 days.

Trigger**Mode**

There are three ways to activate Backup function.

Touch trigger

Touch the Backup object to activate backup operation.

External trigger (bit)

Register a bit device to trigger the backup operation.

Select whether the backup operation is activated after Off to ON, ON to OFF transition, or at both of the changes of state.

External trigger (word)

Users can specify the number of days to backup data using [Trigger address]. [Trigger address] usage (suppose LW-n is used):

LW-n: Will start to back up when the value changes from 0 to 1.

LW-n+1: The start date of backup.

LW-n+2: The number of days for backup. (The maximum: 90 days).

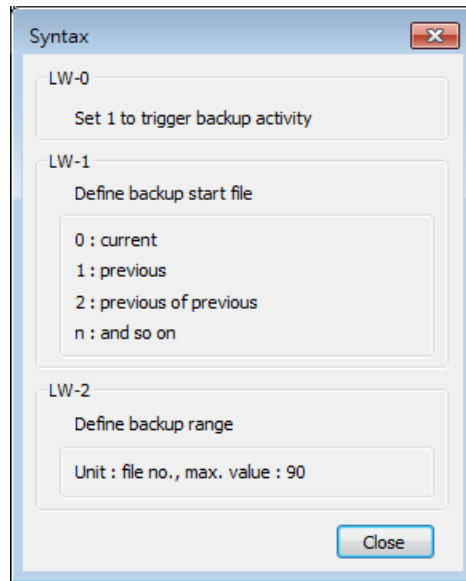

On cMT-SVR, Backup (Trigger-based) object only supports [Touch trigger] mode but not [External trigger (bit)] and [External trigger (word)] modes.

**Trigger
address**

When the state of the designated register is set ON, the backup operation is activated. When the backup operation is done, the state of the designated register is set OFF.

 **Note**

- All history files should have been saved in memory, either HMI memory, USB disk or SD card. Otherwise, the Backup object will not work.
- The maximum number of days for backup is 90 days.
- When saving files to USB disk or SD card, the capacity of a FAT32 folder depends on the length of the file names. Fewer files can be saved when the file names are longer.

 For cMT / cMT X Series, see “7 Event Log” and “8 Data Sampling” that explain the mechanism of synchronizing data to external device.

Output Tab

cMT / cMT X Series

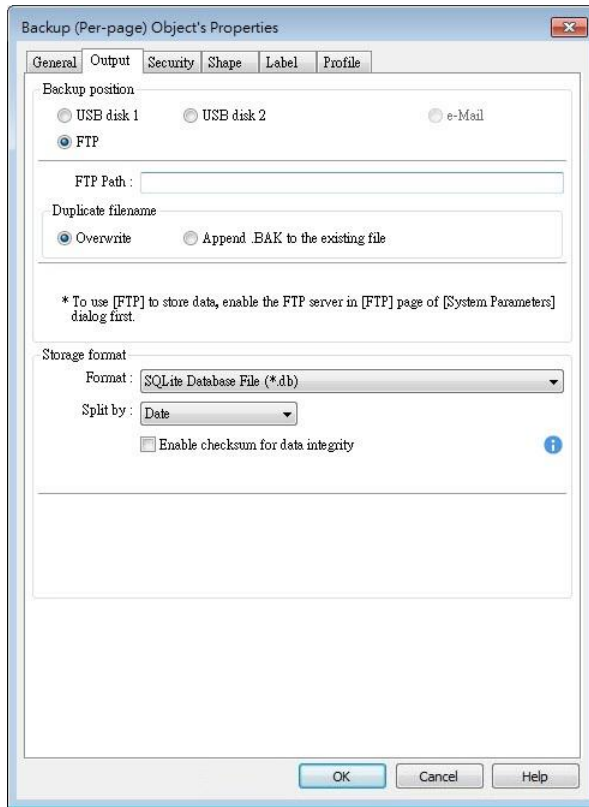

eMT, iE, XE, mTV Series

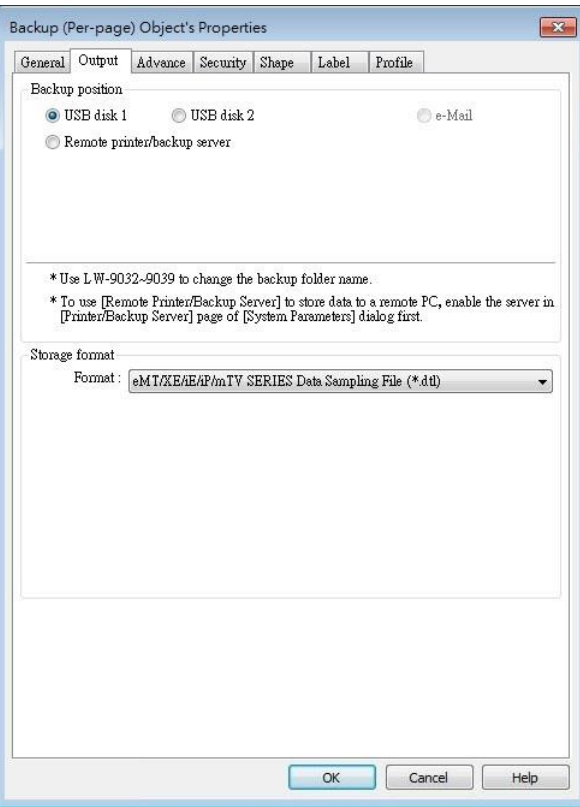

Setting

Description

Backup position

Select the destination where the source files will be saved to.

SD card / USB disk

The external device connected to HMI.

Remote printer/backup server (eMT, iE, XE, mTV Series)

This option is available when [System Parameters] » [Printer/Backup Server] » [Use Remote Printer/Backup Server] is selected.

Please note that [Operation log] backup can only be saved to Remote printer/backup server. To save into a SD card or USB drive, use the control address of Operation Log object.



For more information, see "26 EasyPrinter".

E-mail

To send backup using e-mail, go to [System Parameters] » [e-Mail] tab to configure first, and then open Backup object's e-Mail tab to configure the recipient address, subject, and message.

FTP (cMT, cMT X Series)

To save backup to an FTP server, go to [System Parameters] » [FTP] tab to enable the FTP function first, and then open Backup object's

Output tab to set the FTP path and the way to handle duplicate filenames.

Save format

Select the desired format to back up the file.

eMT, iE, XE, mTV Series:

- HMI Event Log File (.evt) / HMI Data Log File (.dtl)
- Comma Separated Values (.csv)

The [Event] column is included in the backup file to indicate the type of the event.

	A	B	C	D	E
1	Event	Category	Date	Time	Message
2	0	1	2013/7/4	16:12:11	Event A
3	2	1	2013/7/4	16:12:12	Event A
4	0	0	2013/7/4	16:12:33	Event B
5	2	0	2013/7/4	16:12:36	Event B
6	0	0	2013/7/4	16:12:37	Event B
7	1	0	2013/7/4	16:12:37	Event B
8	2	0	2013/7/4	16:12:39	Event B
9	0	0	2013/7/4	16:12:40	Event B

- 0 = Event is triggered
- 1 = Event is acknowledged
- 2 = Event returns to normal

EasyConverter can be used to easily convert HMI Event Log File (.evt) and HMI Data Log File (.dtl) to .xls or .csv format.

- SQLite Database File (.db)

cMT / cMT X Series:

- SQLite Database File (.db) (Only for backup to e-mail)
- Comma Separated Values (.csv)

Split by

No split	Backup all historical data to the same file.
Date	Files are separated according to the date of historical data. When [Customized file handling] is used in Data Sampling, the backup files are separated in the same way they are by the rules of customized file handling.
Number of rows	Files are separated according to the number of rows set.

Add BOM (Byte Order Mark) to file header for EXCEL can interpreting non-ASCII strings correctly.

To back up history logs in .csv format, open the csv file in EXCEL. The BOM (Byte Order Mark) can be added to the file header so that the .csv file containing non-ASCII strings can directly be opened in EXCEL. The title, export time, occurrence count, and elapsed time can

be included or omitted in the backed-up .csv file.

Storage format

Format : Comma Separated Values (*.csv)

Split by : Date

Add BOM (Byte Order Mark) to file header for EXCEL can interpreting non-ASCII strings correctly

Include title Include export time

Include occurrence count Include elapsed time

Enable checksum for data integrity

This option is provided for using Backup object to generate a backup file with checksum. EasyConverter can then be used to examine data integrity.

Advance Tab (eMT, iE, XE, mTV)

Backup Object's Properties

General Advance Security Shape Label Profile

Serial number (range : 00000 ~ 65535)

Enable

Source

PLC name : Local HMI Settings...

Address : LW 0

* For example, when serial number is 123 :

A data sampling file - 20140407.dtl will be backed up to 2014040700123.dtl.

An event log file - 20140407.evt will be backed up to 2014040700123.evt.

Options

Remove old files after backup

Setting	Description
Serial number	<p>If enabled, when backing up history files, a user-defined, 5-digit serial number can be appended to the end of the file name of the history data backup.</p> <p>The serial number is determined by the value in the designated source address. After backup, the value of this LW address will automatically increment by 1.</p> <p>The range of the serial number is 0~65535</p> <p>For example, if the serial number is 123, the appended 5 digits will be 00123.</p> <p>A data sampling file -20140407.dtl will be backed up as 2014040700123.dtl.</p> <p>An event log file -20140407.evt will be backed up as 2014040700123.evt.</p>

Options

Remove old files after backup

If selected, the old history files will be removed after backup.

 **Note**

- cMT / cMT X Series does not support Advance settings.

e-Mail Tab

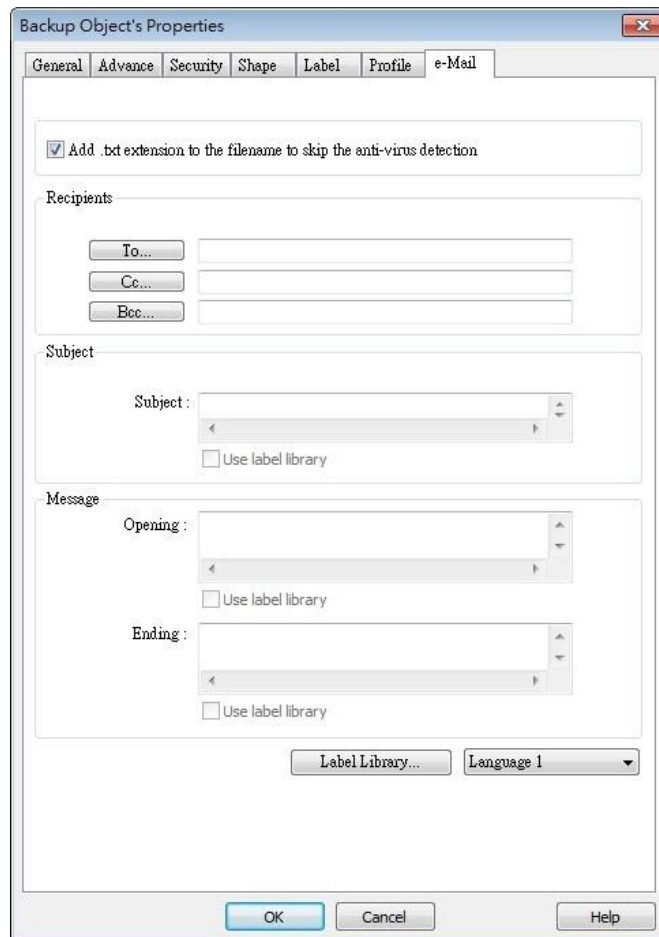

Setting	Description
<p>Add .txt extension to the filename to skip the anti-virus detection</p>	<p>If selected, when sending backup data as an email attachment, the filename extension .txt will be added to the file name. This prevents the mail server or anti-virus software from blocking emails.</p>
<p>Recipients, Subject, Message</p>	<p>Back up the email address of the recipients, the subject of the email, and the message content.</p>

13.25. Media Player

13.25.1. Overview

Media Player object plays video files on HMI. It can, for example, be useful in providing better instructions onsite to facilitate maintenance.

This object does not work remotely on cMT Viewer.

13.25.2. Configuration



Click [Object] » [Media Player] icon on the toolbar to open a Media Player object property dialog box. Set up the properties, press OK button, and a new Media Player object will be created.

General Tab

cMT / cMT X (excluding cMT-SVR)

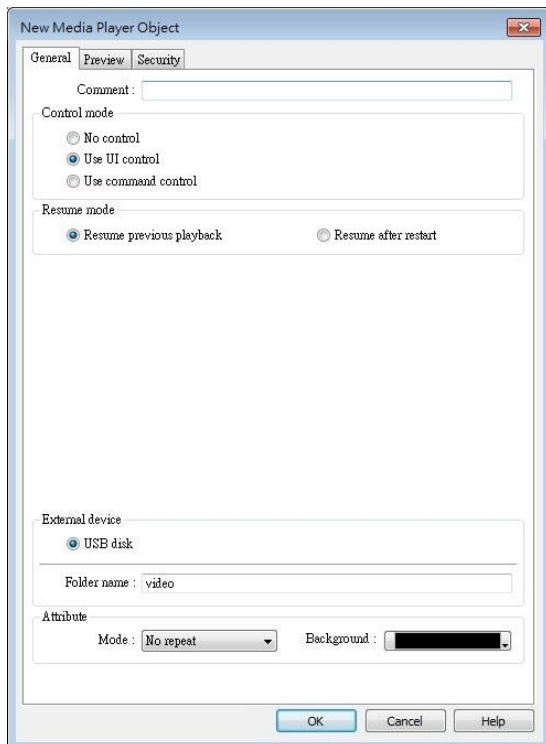

eMT, XE

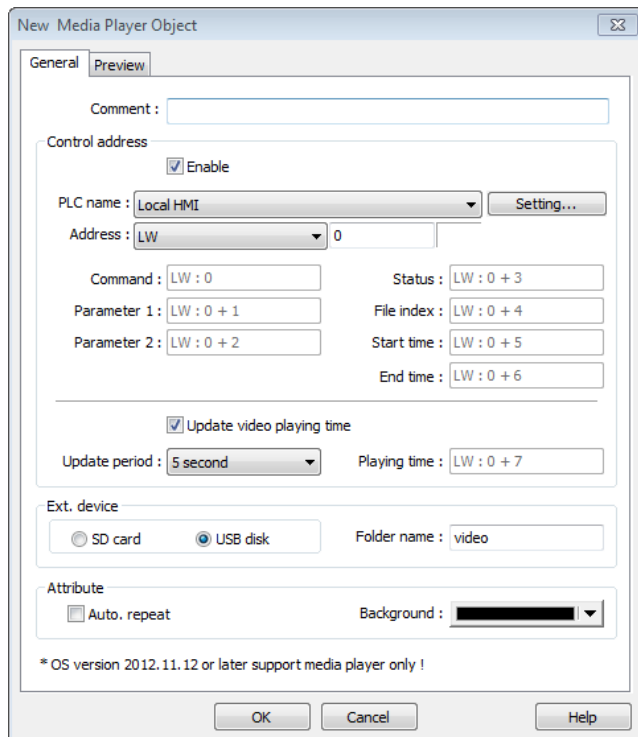

Setting	Description
Control mode	No control: Disable manual control by user. Video playback starts as soon as the window opens.

	<p>Use UI control: Use built-in user interface to control media playback.</p> <p>Use command control: Use control addresses to control media playback.</p>
Resume mode	<p>Defines where to resume video playback when changing back to a window with media player. Options include Resume previous playback and Resume after restart.</p>
Control address	<ul style="list-style-type: none"> ● Selected <p>Designate a word register to control the object operations.</p> <ul style="list-style-type: none"> ● Not selected <p>No manual control. Video will be played automatically when the designated window opens.</p> <p>Command (control address + 0) Enter a value in the Command register to designate which action is executed.</p> <p>Parameter 1 (control address + 1) Enter a value in Parameter 1 associated with each command action.</p> <p>Parameter 2 (control address + 2) Enter a value in Parameter 2 associated with each command action.</p> <p>Status (control address + 3) Indicates the status or errors.</p> <p>File index (control address + 4) The file number in the designated folder. It is recommended to file the video name with a number.</p> <p>Start time (control address + 5) The start time of the video (second). 0, normally.</p> <p>End time (control address + 6) The end time of the video (second). (The time length of the video)</p> <p>Update video playing time If enabled, the elapsed playing time of video will be written into [Playing time] register at a rate set by [Update period] in seconds.</p> <p>Update period Update period of [Playing time], range from 1 to 60 (second).</p> <p>Playing time (control address + 7) The elapsed playing time of video (Second). Normally between start time and end time.</p>
Ext. device	<p>Play video files in SD card / USB disk.</p> <p>Folder name The folder name of video files stored in SD card or USB disk. Files must be stored in root directory. Subdirectories won't be accepted. (For example, "example\ex" is an invalid directory.) [Folder name] cannot be empty, must be alpha-numeric, and all in</p>

	ASCII character.
Attribute	<p>Auto. repeat When finish playing all the video files, replay from the first file. Ex: Video 1 > Video 2 > Video 1 > Video 2</p> <p>Background The background color of the object.</p>

Note

- The data format for control address is 16-bit Unsigned or 16-bit Signed. If using 32-bit Unsigned or 32-bit Signed, only the previous 16 bits will be effective.

Control command

The following are the settings of different commands.

- **Play index file**

[Command] = 1

[Parameter 1] = file index

[Parameter 2] = ignore (set 0)

Note

- Files are stored with file names in ascending order.
- If the file cannot be found, [Status] bit 8 is set ON.
- Please stop the playing video before switching to another.

- **Play previous file**

[Command] = 2

[Parameter 1] = ignore (set 0)

[Parameter 2] = ignore (set 0)

Note

- If [File index] is zero, the same file is replayed.
- If the file cannot be found, [Status] bit 8 is set ON.

- **Play next file**

[Command] = 3

[Parameter 1] = ignore (set 0)

[Parameter 2] = ignore (set 0)

- If there are no more files, the index 0 file is played.
- If the file cannot be found, [Status] bit 8 is set ON.

- **Pause / Play Switch**

[Command] = 4
[Parameter 1] = ignore (set 0)
[Parameter 2] = ignore (set 0)

- **Stop playing and close file**

[Command] = 5
[Parameter 1] = ignore (set 0)
[Parameter 2] = ignore (set 0)

- **Start playing from the designated time**

[Command] = 6
[Parameter 1] = target time (second)
[Parameter 2] = ignore (set 0)

 **Note**

- Parameter 1 (target time) must be less than the ending of time or it plays the last second.

- **Forward**

[Command] = 7
[Parameter 1] = target time (second)
[Parameter 2] = ignore (set 0)

 **Note**

- Going forward to the designated second in [Parameter 1]. If the video is paused, the forwarding action will be started by playing.
- When the designed time is later than the end time, it plays the last second.

- **Backward**

[Command] = 8
[Parameter 1] = target time (second)
[Parameter 2] = ignore (set 0)

 **Note**

- Going Backward to the designated second in [Parameter 1], if the video is paused, the backward action will be started by playing.
- When the designed time is earlier than the beginning time, it plays from beginning.

- **Adjust volume**

[Command] = 9
[Parameter 1] = volume (0 ~ 128)

[Parameter 2] = ignore (set 0)

 **Note**

- Default volume is 128.
- **Set video display size**
 [Command] = 10
 [Parameter 1] = display size (0 ~ 16)
 [Parameter 2] = ignore (set 0)

 **Note**

- [Parameter 1 = 0] : Fit video image to object size.
- [Parameter 1 = 1 ~ 16] : Magnification from 25% ~ 400% in 25% increments where 1 = 25%, 2 = 50%, 3 = 75% and so on.

- **Status (control address + 3)**

When playing a video the system sets [File Open (bit00)] and [File Playing (bit01)] to ON. If the file cannot be found, or an invalid command is entered, the Command Error bit 08 is set ON. If the file format is not supported, or a disk I/O error occurs, during playback, the File Error bit 09 is set ON.

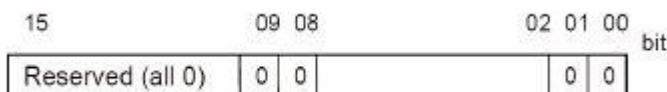

- 00: File Opened / Closed (0 = closed, 1 = opened)
- 01: File Playing (0 = not playing, 1 = playing)
- 08: Command Error (0 = accepted, 1 = incorrect)
- 09: File Error (0 = accepted, 1 = incorrect)

 **Note**

- The figure shows the status value associated with each state:
 Stop = 0, Pause = 1, Playing = 3



- [Command], [Parameter 1], and [Parameter 2] are write addresses. All others are read

only.

Preview Tab

Users can test whether the video format is supported by using the preview function.



Setting	Description
Forward << / Backward >>	Go forward or backward of the video. (in minutes)
Play / Pause	Select to start playing video or pausing.
Stop	Stop playing and close the video file. To test another video, please stop playing the current video first.
Load	Select a video to preview.

Note

- Only one video file can be played at one time.
- If [control address] is not enabled and [Auto. repeat] is not selected, after finish playing the first file, the system will stop playing and close the video file.
- If [control address] is not enabled, the system will find the first file in the designated folder and start to play (in ascending order of the file name).
- If the file can be previewed, the format is supported. If the video image quality is poor, please adjust the resolution.
- The supported formats: mpeg4, xvid, flv...etc.
- The recommended frame rate for videos is 30fps.

13.26. BACnet Schedule

13.26.1. Overview

BACnet Schedule helps visualize and access schedule data (Schedule) in BACnet IP controller with a graphical UI. This feature is only applicable for cMT / cMT X Series HMI.

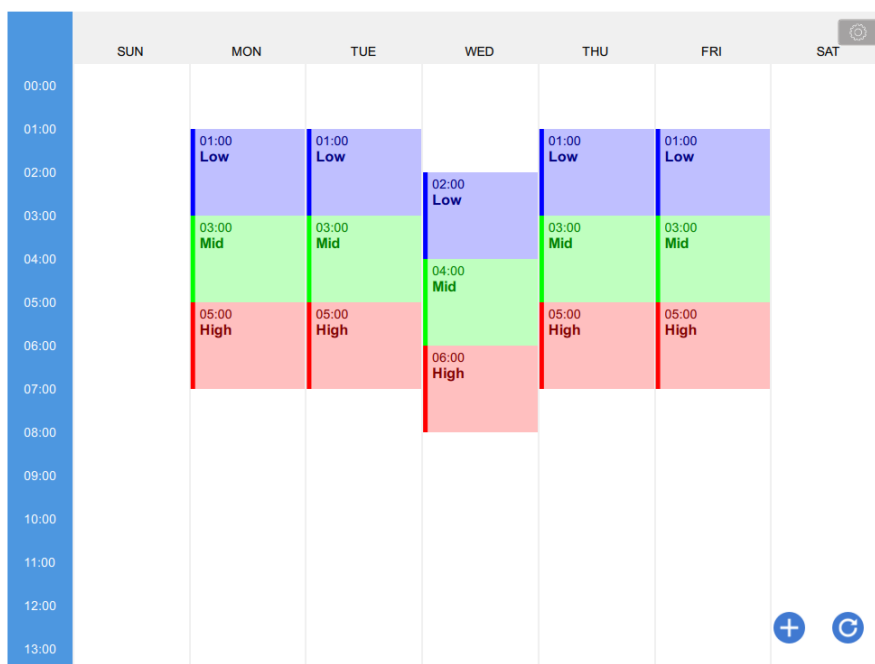

13.26.2. Configuration





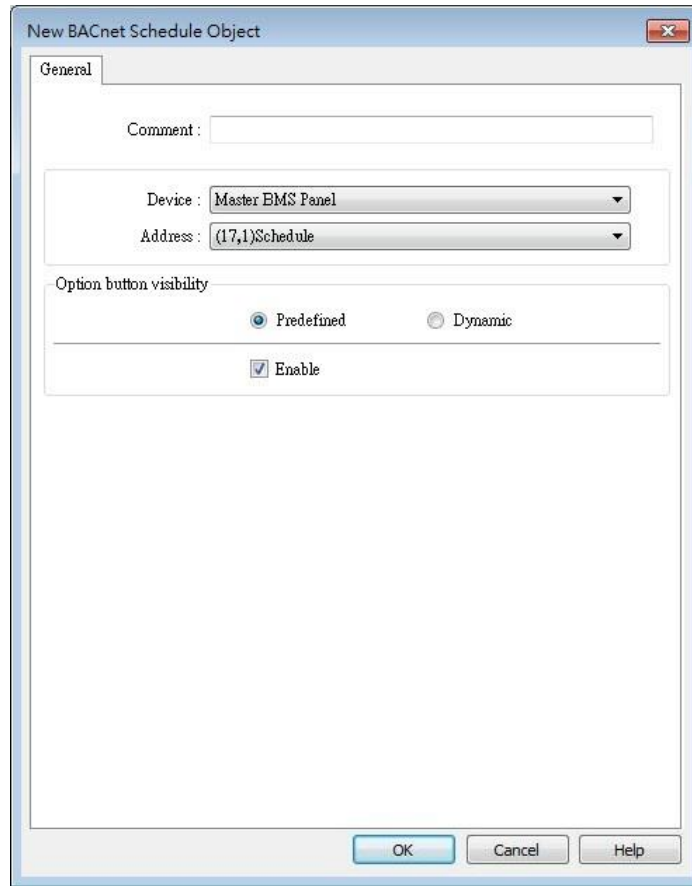

Add BACnet/IP driver into the device list in System Parameter Settings and check whether a Scudule is contained in the scanned BACnet/IP device or the imported tag file.

Click [Object] » [Time Related] »[BACnet Schedule] icon on the toolbar to open the BACnet Schedule property dialog box. Configure the parameters and then click OK, a BACnet Schedule object is created.

General Tab



Setting	Description
Device	Select the BACnet/IP device to be read.
Address	Select the address tag of the Schedule to be read.
Option button visibility (cMT / cMT X Series)	<p>Show or hide the option button .</p> <p>Predefined Select [Enable] to show the option button.</p> <p>Dynamic</p> <div data-bbox="502 1579 1045 1747" style="border: 1px solid gray; padding: 5px;"> <p>Option button visibility</p> <p><input type="radio"/> Predefined <input checked="" type="radio"/> Dynamic</p> <hr/> <p>Device : Local HMI   </p> <p>Address : LB <input type="text" value="0"/></p> </div> <p>Designate a bit address to control option button visibility.</p>

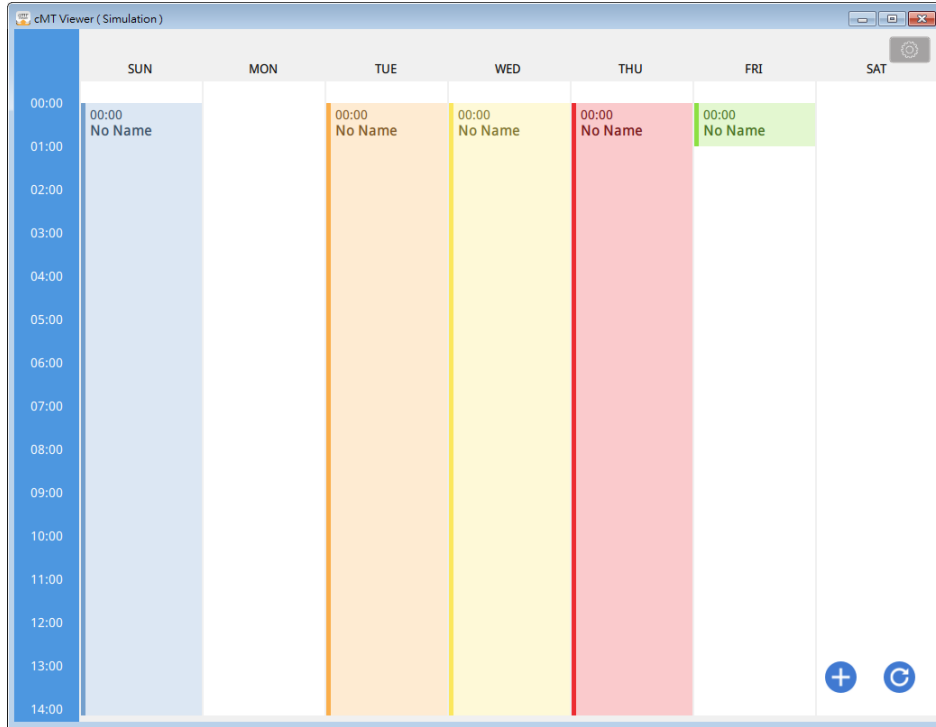

Example 1

After downloading the project to HMI, the HMI will automatically read the schedule settings in the BACnet IP device as shown below.

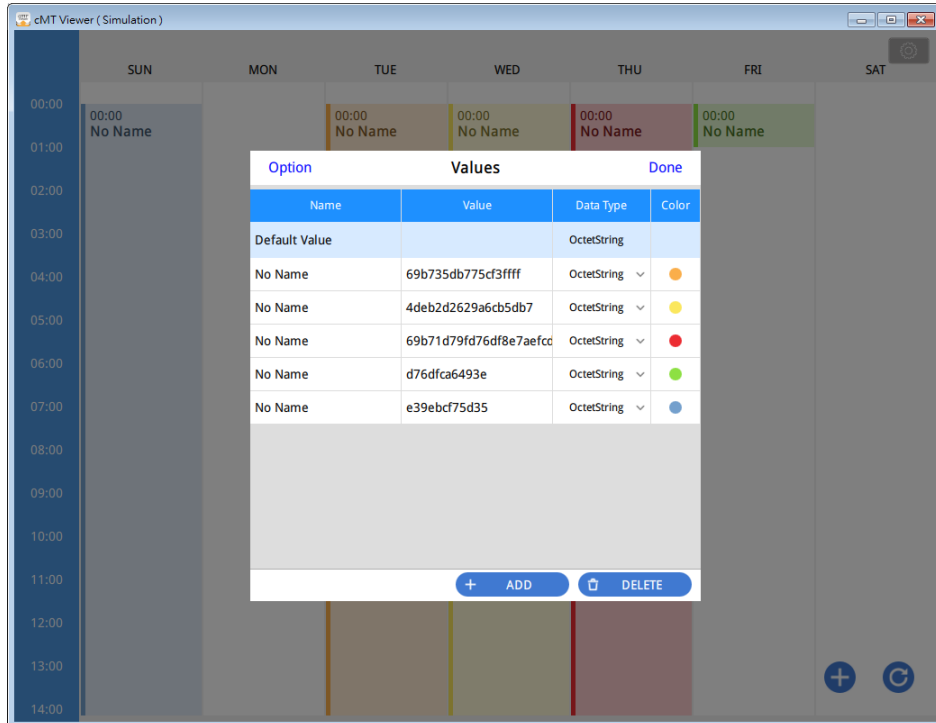

Click  and then select Value Editor to configure the Values table containing these columns: Name, Value, Data Type, and Color, as shown below.



Click  to add a schedule setting. Click  to refresh schedule data by reading from the BACnet device.

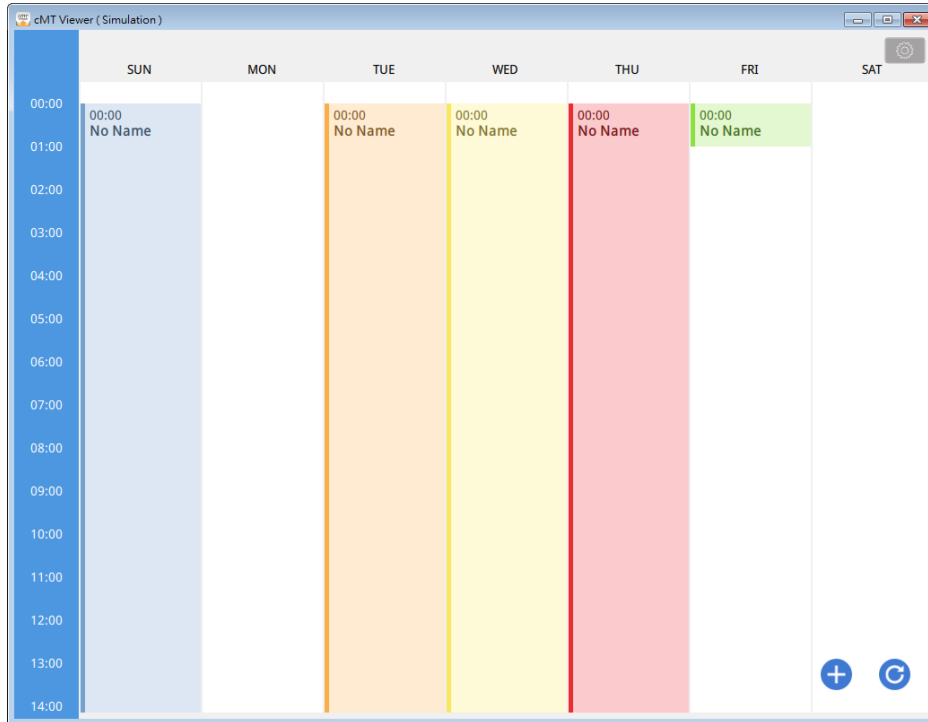

As shown in the following screenshot, in a schedule settings window, the Weekday, start time (From), end time (To), and Value should be configured. Value can be selected from the value table. (Clicking  open Value Editor for editing the value table as well.)

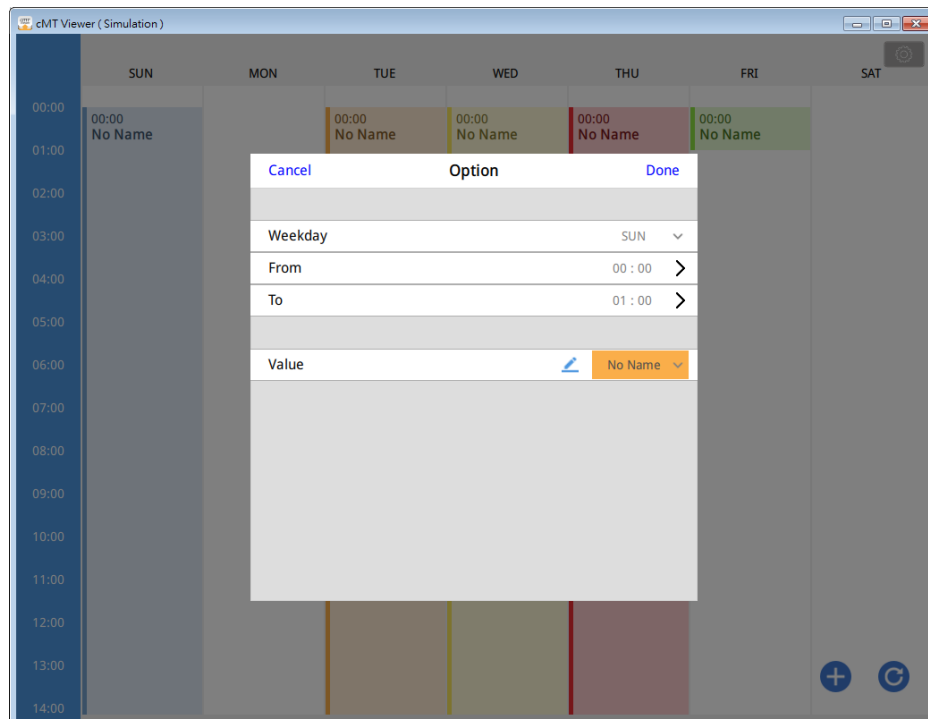

After the time settings are completed, the values will be written to the corresponding schedule tags in BACnet device.

13.27. PLC Control

13.27.1. Overview

PLC Control object can execute commands when it is triggered.

13.27.2. Configuration



Click [Object] » [PLC Control] icon on the toolbar to open the PLC Control Object management dialog box. To add a PLC Control object, click [New], set up the properties, press OK button and a new PLC Control object will be created.

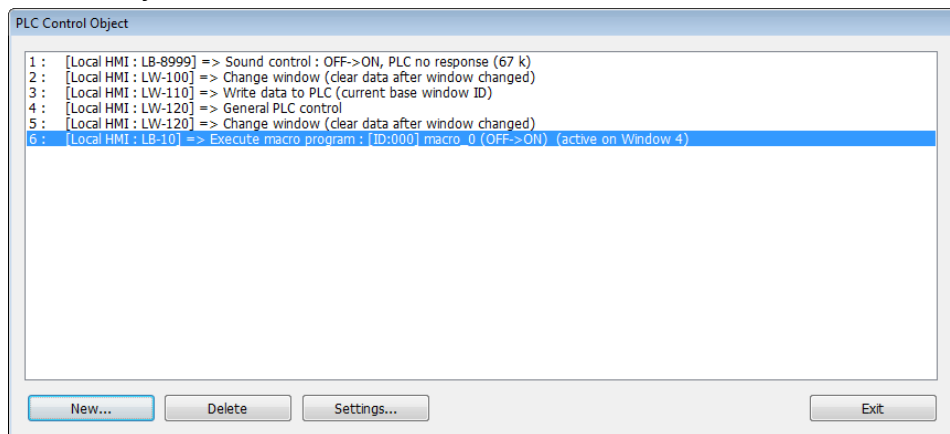

Click [New] and the following dialog box appears. See “13.27.2.1 Type of Control”.

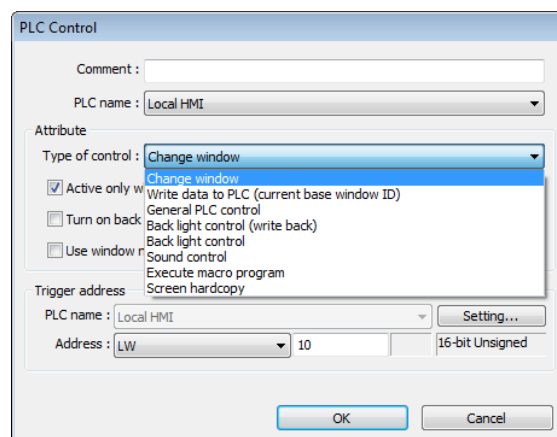

Note

- The [General PLC Control] option is not available for cMT / cMT X Series.
- Triggering [Screen hardcopy] in cMT Viewer will result in files being saved into the USB disk / SD card connected to the cMT / cMT X HMI. Likewise, the [Back light control] option in cMT Viewer will control the backlight of the HMI itself.

- Selecting [Change window] or [General PLC Control] as [Type of control] will require more than one trigger word (consecutive). Using a user-defined tag PLC will require declaring an array datatype.

13.27.2.1. Type of Control

- **Change window**

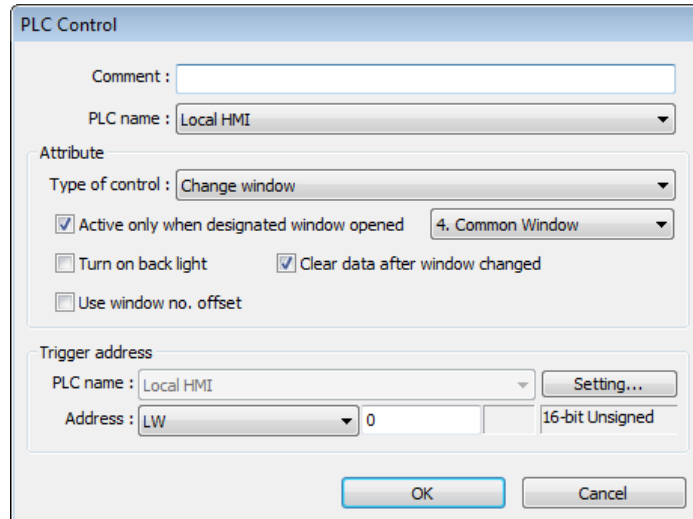

Setting	Description
Active only when designated window opened	Allow this operation only if a particular screen is displayed.
Turn on back light	The backlight is turned ON when the window is changed.
Clear data after window changed	Reset the value at trigger address to zero when the window object is changed. If [Use window no. offset] is selected, this option will only show when a negative offset is used.
Use window no. offset	Select the check box and select a window offset, the new window no. to change to will be the value in [Trigger address] plus the offset. For example, if [Trigger address] is LW-0 and offset is set to -10. When the value in LW-0 is 25, the system will change to window no. 15 (25-10=15). The range of the offset is -1024 to 1024.

 **Note**

- If [LB-9017] is set ON, the write-back function will be disabled, the new window number is not written back into a designated address.

Place a valid window number in the designated trigger address to change the base screen to the new window number. The new window number is written back into the designated

address.

For example, if current window is window no. 10, and [Trigger address] is set to LW-0, When LW-0 is changed to 11, the system will change the current window to window no. 11, and then write 11 to LW-1.

When the window is changed, the new window number is written back into the address that is calculated by [Trigger address] and the data format, as shown in following table.

Data Format	Trigger address	Write address
16-bit BCD	Address	Address + 1
32-bit BCD	Address	Address + 2
16-bit Unsigned	Address	Address + 1
16-bit Signed	Address	Address + 1
32-bit Unsigned	Address	Address + 2
32-bit Signed	Address	Address + 2
64-bit Unsigned	Address	Address + 4
64-bit Signed	Address	Address + 4

- **Write data to PLC (current base window)**

Each time the base window is changed, the new window number will be written into the [Trigger address]. If [Use window no. offset] is selected, the window number of the base window plus the window number offset will be written into the [Trigger address].

- **General PLC Control (eMT, iE, XE, mTV)**

Transfer word data blocks from PLC to HMI, and vice-versa, and the transfer direction is controlled by the value in the [Trigger address].

Value in [Trigger address]	Action
1	Transfer data from PLC register → HMI RW register
2	Transfer data from PLC register → HMI LW register
3	Transfer data from HMI RW register → PLC register
4	Transfer data from HMI LW register → PLC register

Four consecutive word registers are used as described in the following table:

Address	Purpose	Description
[Trigger address]	Determine the direction of data transfer	The valid values are listed in the above table. When a new control code is written into the register, HMI will start to transfer. After data transfer is finished, the value will be set to 0.
[Trigger address] +1	The size of data to transfer.	The unit is word.
[Trigger address] +2	Offset to the start address of PLC register	Assume the value is "n", where n is an arbitrary number, the start address of PLC register is [Trigger address + 4 + n]. Take an OMRON PLC as an example: If [Trigger address] uses DM-100, [Trigger address + 2] will be DM-102. If the value in DM-102 is 5, the start address of data source would be DM-109 (100 + 4 + 5 = 109).
[Trigger address] +3	Offset to the start address of LW or RW memory in HMI	Take OMRON PLC as an example: If set [Trigger address] to DM-100, [Trigger address + 3] will be DM-103. If the value in DM-103 is 100, the start address of memory in HMI is RW-100 or LW-100.

Example 1

To use PLC Control object to transfer 16 words data in OMRON PLC, starting from address DM-100, to the HMI address, starting from RW-200. The setting is shown below:

1. Firstly, create a PLC Control object, set [Type of control] to [General PLC control], and set [Trigger address] to DM-10, that is, to use the four sequential registers start from DM-10 to control data transfer.
2. Confirm the data size and the offset addresses.
Set DM-11 to 16, since the number of words to transfer is 16 words.
Set DM-12 to 86, which indicates the address of data source is DM-100 (100=10+4+86).

Set DM-13 to 200, which indicates the destination address is RW-200.

3. Set DM-10 according to the direction of data transfer.

If set DM-10 to 1, the data will be transferred from PLC to HMI RW register,

If set DM-10 to 3, the data will be transferred from HMI RW register to PLC.

- **Back light control (write back)**

When [Trigger address] is turned ON, HMI backlight will be turned ON/OFF and [Trigger address] will be turned OFF. Any touch on the screen will turn the backlight on.

- **Back light control**

When [Trigger address] is turned ON, HMI backlight will turn ON/OFF and the state of [Trigger address] will not be changed.

- **Sound control**

When the state of the designated [Trigger address] changes, the HMI will play the sound selected from the sound library. There is a further selection determines whether the sound is played after Off to ON, ON to OFF transition, or at both of the changes of state.

- **Execute macro program**

Select a pre-defined Macro from the drop-down list. When the state of the designated [Trigger address] changes, the selected Macro is executed. There is a further selection determines whether the Macro is executed after Off to ON, ON to OFF transition, or at both of the changes of state. If select [Always active when ON], the macro will be executed repeatedly. (The shortest time interval between runs is 0.5 second.)

- **Screen hardcopy**

The screenshot shows the 'PLC Control' dialog box with the 'Screen hardcopy' section selected. The configuration is as follows:

- Comment:** (Empty text field)
- Device:** Local HMI
- Attribute:**
 - Type:** Screen hardcopy
 - Active only when designated window opened
 - Rotate image 90 degrees
- Trigger:**
 - Device:** Local HMI
 - Address:** LB 0
- Screen hardcopy:**
 - Trigger mode:** OFF->ON
- Source window:**
 - Current base window
 - Window no. from register
 - Designate window no.
 - Device:** Local HMI
 - Address:** LW 0
 - Output to:** USB disk 1
 - Customized filename handling
 - Crop window

Buttons for 'Settings...' and 'OK'/'Cancel' are visible at the bottom.

When the state of the designated [Trigger address] changes, print the selected screen. If select [SD card] or [USB disk] as [Printer], a “hardcopy” folder will be generated in the selected external device for saving the printed screen in JPG format. The name of the JPG files starts from yyyyymmdd_0000.

To print the screen using a printer, go to System Parameter Settings » Model tab and set the printer.

To print the screen using a remote printer, go to System Parameter Settings » Printer/Backup Server tab and configure the parameters.

There are three options to specify the source window for hardcopy:

Current base window

Print the base window currently opened.

Window no. from register

Print the window designated by the value in a designated word address.

Designate window no.

Directly select a window to be printed.

Customized File Handling

This feature can be used to customize naming of the folders and the JPG files.

Setting	Description
Folder name	<p>The folder name can be an alphanumeric name, and certain half-width symbols are allowed: !@#\$%^&()_+{}`-=';,. The folder name can also be specified by a naming syntax.</p> <p>Dynamic format</p> <p>The folder names can be set by a designated word address, or by a naming syntax indicating the current system time. The syntax can be specified by selecting time buttons or entering the syntax in Format field. The length limit is from 1 to 25.</p> <p>Note: Up to 10 layers of folders can be created. The exceeding layers will be ignored.</p>
File name	<p>The way to specify a file name is similar to specifying a folder name.</p> <p>Note: If the file name already exists, the system will add “_0001” to the file name as a serial number. The numbers of the later files add up until “_9999”. The files after “_9999” will be ignored.</p> <p>For example, if the three file names exist: “A.jpg”, “A_0001.jpg”, “A_0003.jpg”. When trigger screen</p>

hardcopy with the same file name, the coming files will be named in this order: "A_0002.jpg", "A_0004.jpg", "A_0005.jpg", and so on.

Crop window

With this option selected, taking a cropped screenshot is possible.

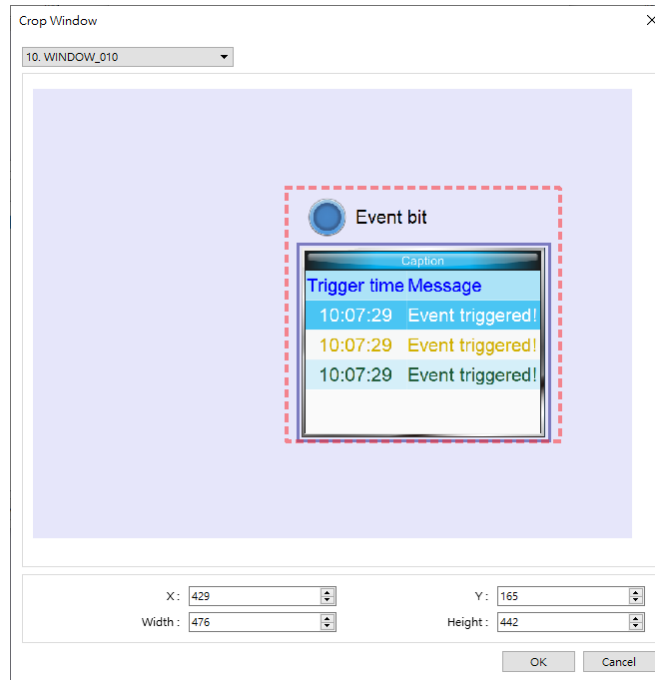

Note

- A background printing procedure is performed when the printed window is not the current base window.
- If the hard-copied window is a background window, its [Direct Window] and [Indirect Window] objects will not be printed.
- When using a dynamic format name, the system will use a “_” sign as a substitute for invalid symbols.
- When using a dynamic format name, if screen hardcopy is triggered without specifying the format first, the system will save the file in the default directory, which is:
hardcopy\yyymmdd_0000.JPG
- On cMT / cMT X models, a triggered bit address is reset to its original state automatically, whereas on eMT/iP/iE/mTV models, the state of a triggered bit address is retained.

13.28. Scheduler

13.28.1. Overview

Scheduler object turns bits ON/OFF, or writes values to word registers at designated start times. It works on a weekly basis.

13.28.2. Configuration



Click [Object] » [Time-related] » [Scheduler] icon on the toolbar to open the Scheduler management dialog box, click [New] to open the Scheduler property setting dialog box.

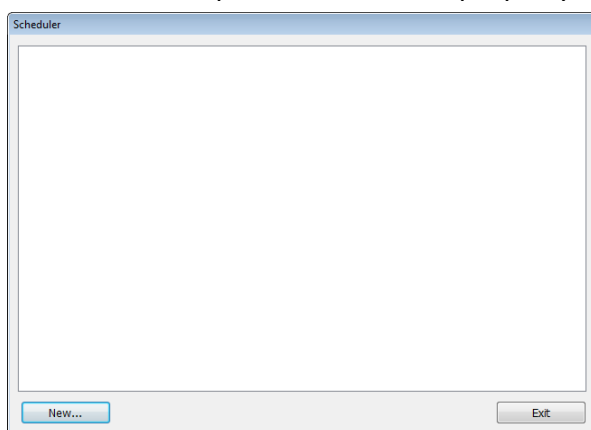

The following two demonstrations explain the usage of Scheduler.

Example 1

A motor is scheduled to power - ON at 9:00 and power – OFF at 18:00, Monday to Friday. We are using LB-100 to control the motor state. LB-100 will be set ON at 9:00 and OFF at 18:00.

1. Click the Scheduler icon on the toolbar to open the Scheduler management dialog box, click [New].
2. In [General] tab, select [Bit ON] in [Action mode] and set [Action address] to LB-100.

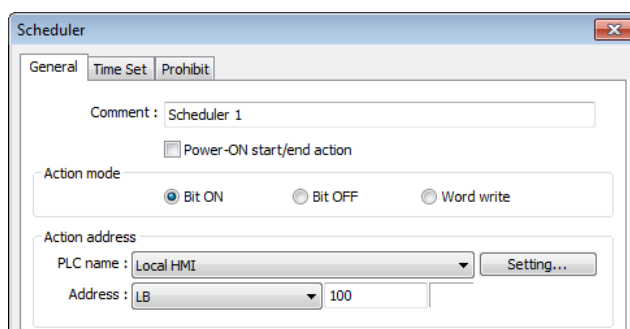

3. In [Time Set] tab, select [Constant].

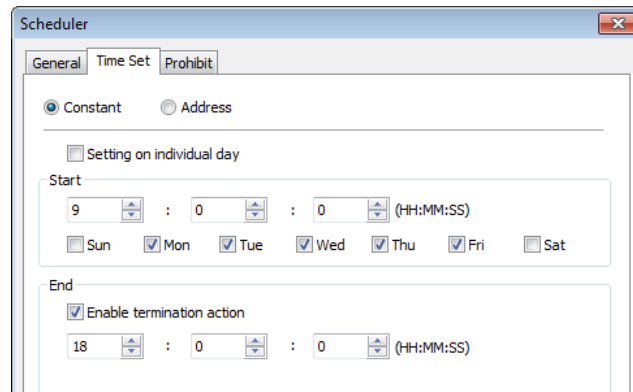

4. Enter [Start] time as 9:00:00 and select Monday to Friday. Do not select [Setting on individual day].
5. Enter [End] time as 18:00:00 and select [Enable termination action] check box.
6. Click [OK], a new Scheduler object will be created on the [Scheduler] list.

Example 2

A thermal heater is scheduled to heat up to 90°C at 08:00 and cool down to 30°C at 17:00, Monday to Friday. LW-100 is used to store the set point value.

1. Click the Scheduler icon on the toolbar to open the Scheduler management dialog box, click [New].
2. In [General] tab, select [Word write] in [Action mode] and set [Action address] to LW-100.
3. Select [Constant] for [Word write value settings] and enter 90 in [Start value].

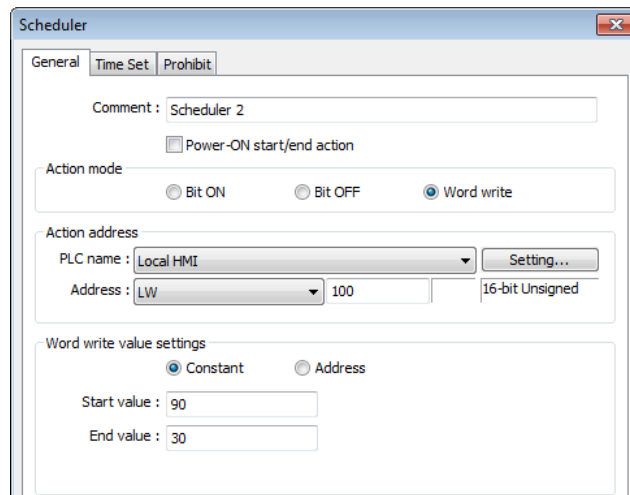

4. In [Time set] tab select [Constant].
5. Enter [Start] time as 8:00:00 and select Monday to Friday. Do not select [Setting on individual day].
6. Enter [End] time as 17:00:00 and select [Enable termination action] check box.
7. Return to [General] tab and enter 30 in [End value].
8. Click [OK], a new schedule object will be created on the [Scheduler] list.

General Tab

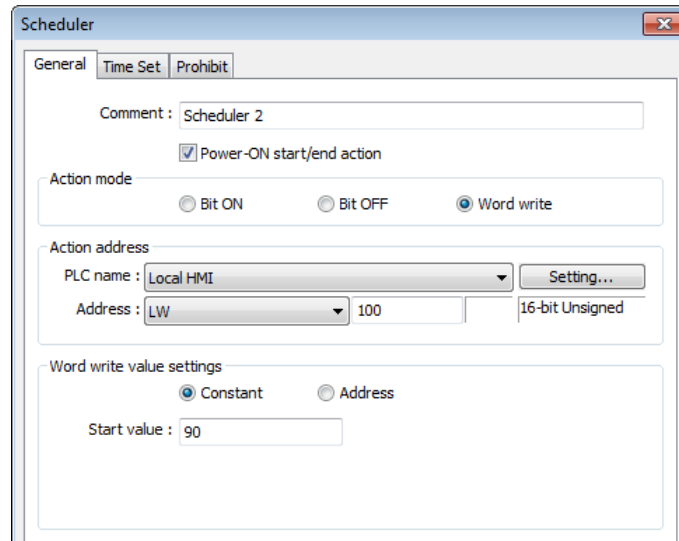

Setting	Description
<p>Power ON start/end action</p>	<p>Execute the defined action when the HMI is powered ON.</p> <ul style="list-style-type: none"> ● Enabled <p>When HMI is powered ON within the scheduled time range, the start action will be performed automatically. When HMI is powered ON outside the scheduled time range, the termination action will be executed.</p> <p>Inside scheduled range</p> <p>Outside scheduled range</p> <ul style="list-style-type: none"> ● Disabled <p>When the HMI is powered ON at a time later than the start time, the start action will not be performed, but the termination action will be performed. When the termination action is not defined, the scheduled range is not recognized and no action is performed.</p>

Action mode

Choose the action to do at the given time.

Bit ON

At the start time, set the designated bit ON. At the end time, set the designated bit OFF.

Example: Start time : 09:00:00 End time : 17:00:00

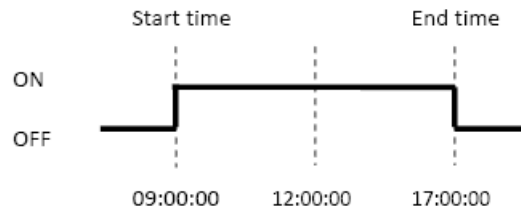

Bit OFF

At the start time, set the designated bit OFF. At the end time, set the designated bit ON.

Example: Start time : 09:00:00 End time : 17:00:00

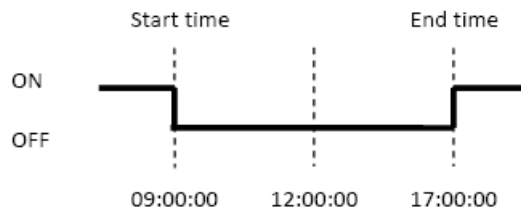

Word write

The [Write start value] entered here is transferred to the designated [Action address] word register at the start time. At end time, the [Write end value] entered here is written to the [Action address]. The valued can be entered manually or be set by using [Address] mode. In [Address] mode, the value in the specified address is the start value where the value in [Address + 1] is the end value.

Example: Device address: LW-100

Start time: 09:00:00 End time: 17:00:00

Write start value: 10 Write end value: 0

Use register: If control address is LW-n, then enter 10 in LW-n and enter 0 in LW-(n+1).

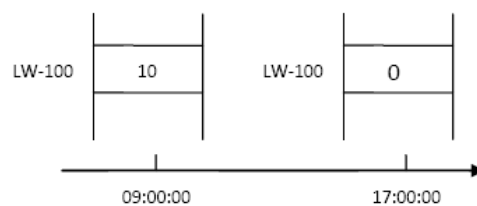

 **Note**

- Only if an [End time] is set in the [Time set] tab will the [Write end value] box appear.

Time Set

Specify start time and end time. [Constant] allows specifying a date or period and time. [Address] allows controlling the time by the designated address.

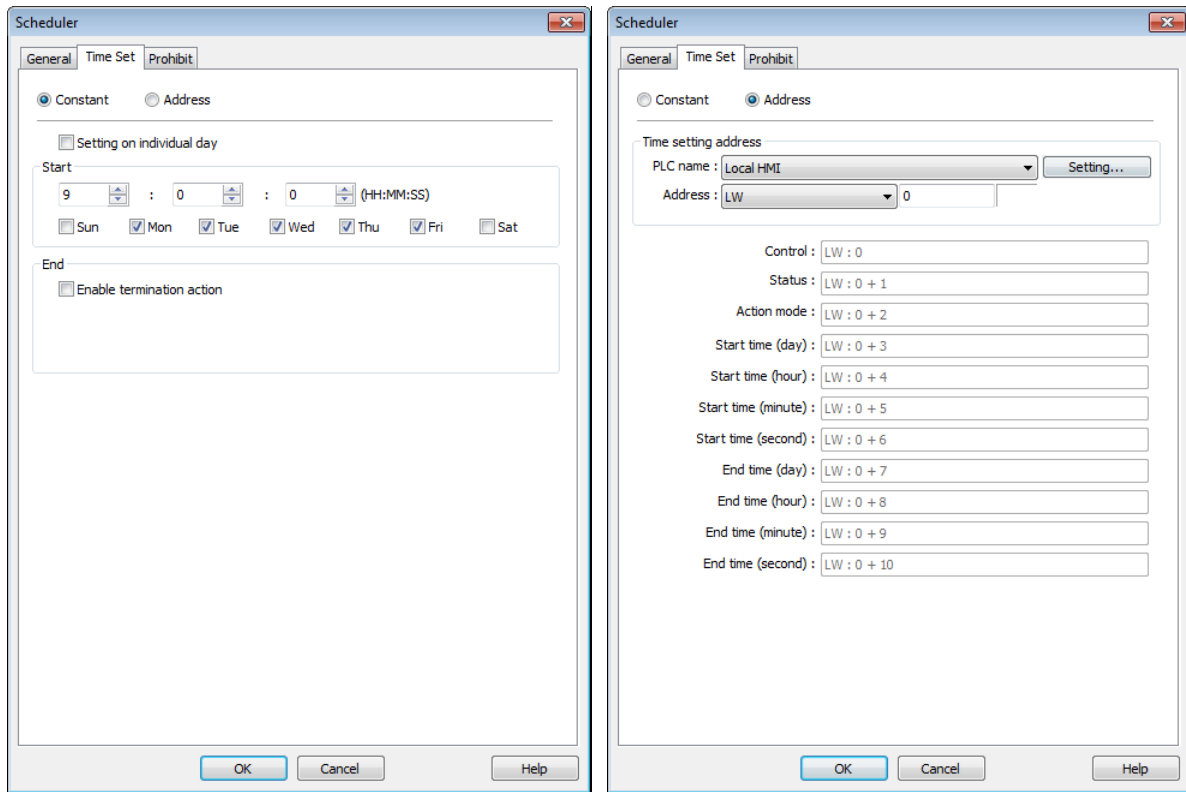

● **Constant**

Setting on individual day

If [Setting on individual day] is selected

The same start time and end time can be assigned to different days of the week.

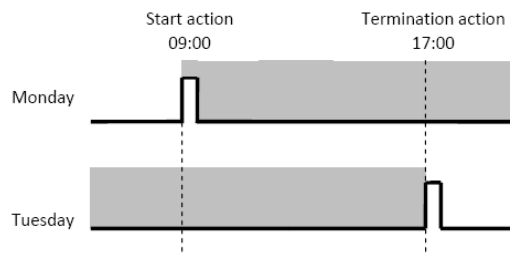
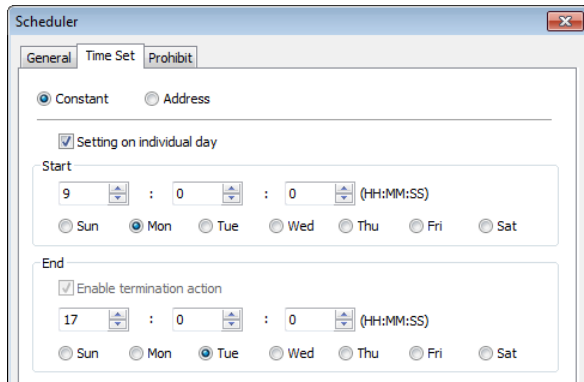

 **Note**

- Start and end time must be entered.
- Start and end time must be on a different time, or same time but different day.

If [Setting on individual day] is not selected

Start time and end time entered must start and end within 24-hours.

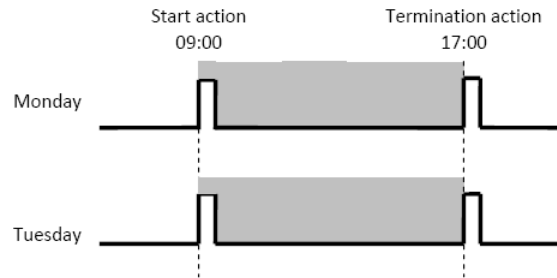
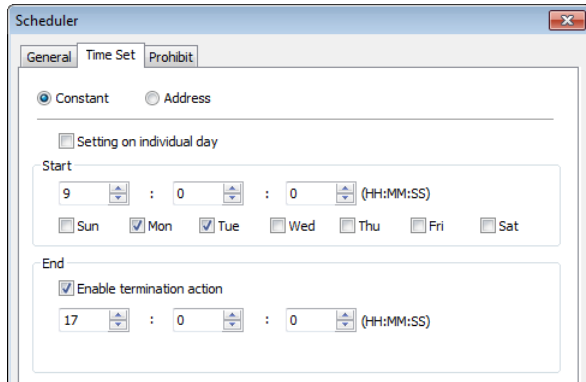

 **Note**

- Start time and end time must be on a different time, different day.
- If an end time is earlier than a start time, the end action will occur in the next day.

Start date: Monday
 Start time: 22:00
 End time: 01:00

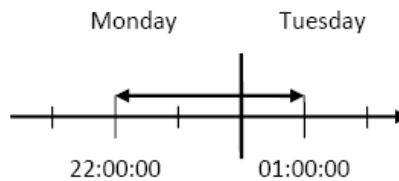

● **Address**

The scheduler object retrieves the start/end time and day of week information from word registers, enabling all parameters to be set and changed under PLC or user control. Designated as the top address in a block of 11 sequential registers which are used to store time setting data.

The format of the 11 word registers should normally be 16-unsigned integer. If a 32-bit word address is chosen, only bits 0-15 are effective, and bits 16-31 should be written as zero.

The following describes each register.

Control (Time setting address + 0)

When [Control] bit is ON, the HMI will read and update [Action mode], [Start time], and [End time] values.



Bit 0: no action 1: read times/action mode

Action mode (Time setting address + 2)

Enable/disable [Enable termination action] and [Setting on individual day]. Whatever the [Enable termination action] bit is, all the time data, from [Control] to [End time (second)], will be read.



Bit 00 Enable termination action (0: Disabled 1: Enabled)

Bit 01 Setting on individual day (0: Disabled 1: Enabled)

 **Note**

- If [Enable termination action] is OFF, all 11 registers are still read but end time is ignored.
- If [Setting on individual day] is ON, make sure that all start end times are entered. If more than one start / end day bit is ON, and error will occur.

Start/End Day (Start Day: Time setting address + 3, End Day: Time setting address + 7)

Designates which day of week is used to trigger the start or end action.

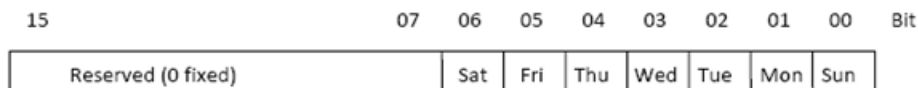

Bit 00 Sunday (0: not used 1: used)

Bit 01 Monday (0: not used 1: used)

Bit 02 Tuesday (0: not used 1: used)

Bit 03 Wednesday (0: not used 1: used)

Bit 04 Thursday (0: not used 1: used)

Bit 05 Friday (0: not used 1: used)

Bit 06 Saturday (0: not used 1: used)

Start/End Time (Start Time: Time setting address + 4 to + 6, End Time: Time setting address + 8 to + 10)

Hour: 0 – 23 Minute: 0 – 59 Second: 0 - 59

Values outside these ranges will cause error.

 **Note**

- 16-bit unsigned integer format must be used; BCD format is not supported here.
- In [Address] mode, [Control] bit should be set after HMI reboots to update scheduler time.
- When using RW address, [Control] bit should be set after HMI reboots to update scheduler time. Placing a Set Bit object with [Set ON when window opens] selected in the common window is recommended, this can retain last settings after HMI reboots.

- End time depends on [Action mode] (address + 2). [Enable termination action] (Bit 00) and [Setting individual day] (Bit 01) are related:

Setting individual day	Enabled	Disabled	
Enable termination action	Enabled	Enabled	Disabled

Prohibit tab

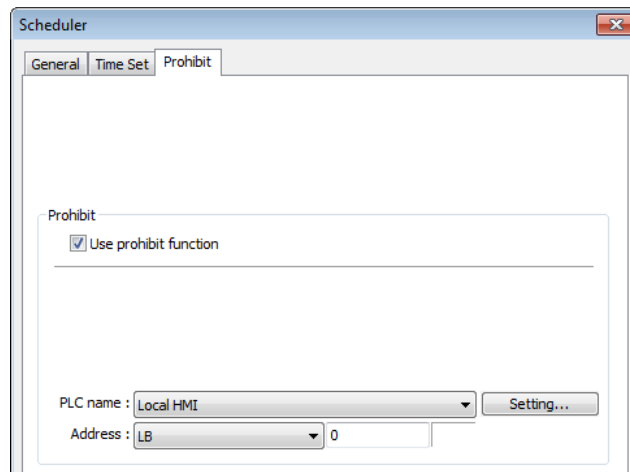

Before the scheduled action is performed, the HMI will read the specified bit state. If it is ON, the scheduled start/end action will be skipped. Otherwise, it will be performed normally.

Note

- The maximum number of Scheduler objects in a project is 64.
- A time schedule applies one action only when the start time is reached.

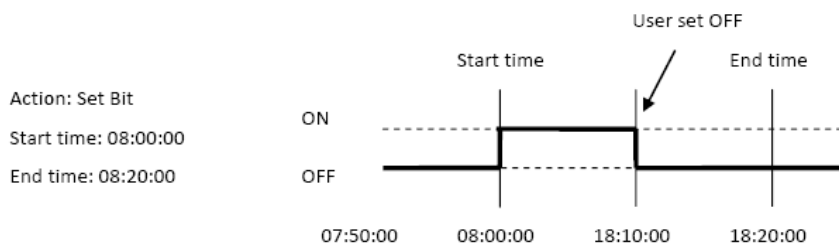

- [Write start/end value] and [Prohibit] bit is read only once before start action. After that, even to change the state of [Prohibit] bit or [Write start/end value], the end action and the value written will not be affected. Also, to read data of [Write start/end value] and [Prohibit] bit, there is a delay of start action due to the communication.
- Each time RTC data is changed, scheduler list entries that possess both start and end times will be checked for in-range or out-range conditions. For in-range, the start action will occur. If the end action is not set, the new range is not recognized, the action will not occur.
- If several Scheduler objects are set to the same start time or end time, the action is performed in ascending order of the schedule number.

- In [Time Set] » [Address] mode, the system will read [Control] word regularly. The length of the period depends on the system.
- In [Time Set] » [Address] mode, when start time and end time is out- range, error occurs in the set action time. (Note: BCD is not an acceptable format)
- In [Time Set] » [Address] mode, the action will not start up until the first time the time data is successfully updated.

13.29. Option List

13.29.1. Overview

Option List object displays a list of items that the user can view and select. Once the user selects an item, the corresponding data will be written to a word register.

There are two forms of this object – [List box] and [Drop-down list]. The [List box] lists all items and highlights the selected one. The [Drop-down list] normally displays only the selected item. Once the object is pressed, the system will display a list (which is similar to list box) as shown in the following figure.

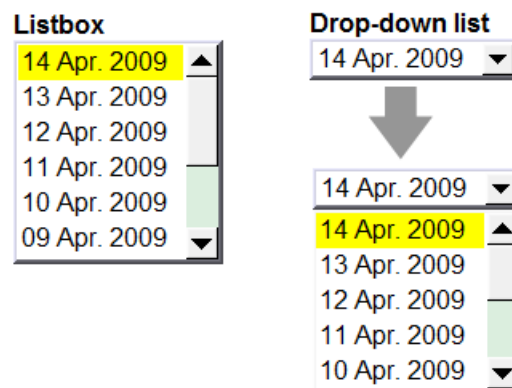

13.29.2. Configuration



Click [Object] » [Option List] icon on the toolbar to open an Option List object property dialog box. Set up the properties, press OK button, and a new Option List object will be created.

Option List Tab

eMT, iE, XE, mTV Series

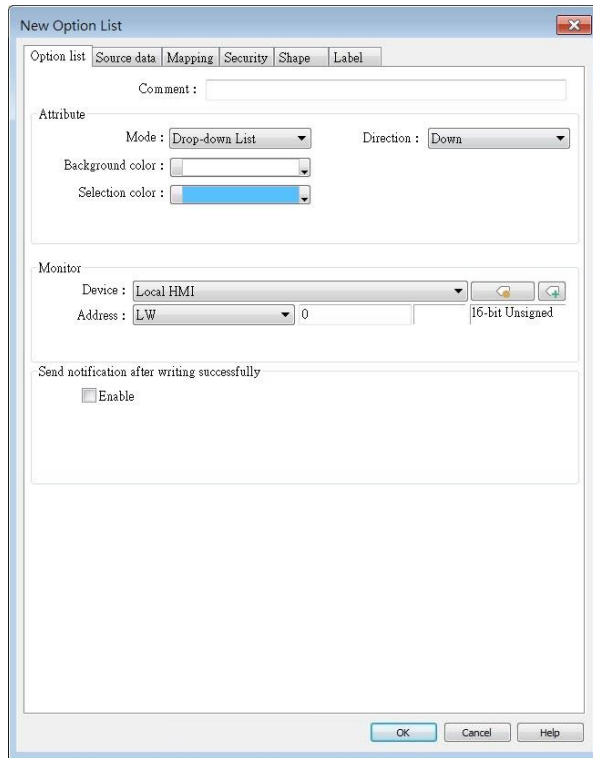

cMT / cMT X Series

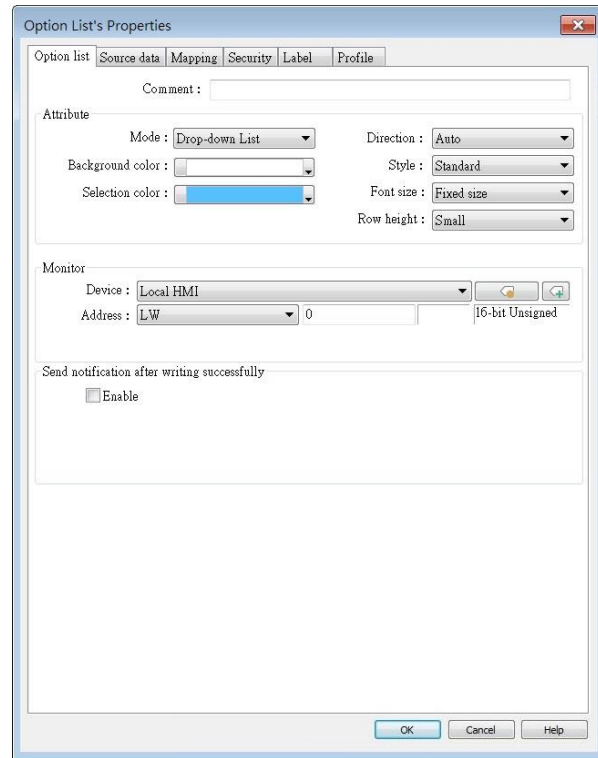

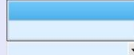
Setting	Description
Attribute	<p>Mode: The list style, either [List box] or [Drop-down list].</p> <p>Background color: Set the background color.</p> <p>Selection color: Set the background color for the selected item.</p> <p>Direction: With the [Auto] option selected, the Option List expands based on its vertical alignment with the window's centerline as the reference. If the Option List is positioned above the centerline, its menu content expands downwards; conversely, if it's positioned below the centerline, the menu content expands upwards.</p> <div data-bbox="496 1570 1257 1794" style="border: 1px solid #ccc; padding: 5px; margin: 10px 0;"> <p>Expands downwards above the centerline.</p>  <hr style="border: 1px solid red;"/>  <p>Expands upwards below the centerline.</p> </div> <p>With the [Down] option selected, the Option List will consistently expand downwards. Conversely, with the [Up] option selected, the Option List will consistently expand upwards.</p> <p>Please note that if the object is positioned near the window's edge</p>

and the option to expand towards the edge is selected, the menu content display will be compressed.

Style: This option is available only when the selected mode is [Drop-down list]. Available styles are: [Standard] and [Classic]. The appearance of the objects will be shown in cMT / cMT X Style when [Standard] is selected, and shown in iE/eMT/XE style when [Classic] is selected. When the project is converted from iE/eMT/XE to cMT / cMT X, the default style will be [Classic].

Font size: When [Same size as label] is selected, the font size set in Label tab will be used for the drop-down list. When [Fixed size] is selected, the system default font size will be used for the drop-down list.

Row height: Set the row height for the drop-down list.

Monitor address	The corresponding value of the selected item will be written to [Monitor address].
Write when button is released	If this check box is selected, the selected item value will be written to [Monitor address] after the button is released.
Send notification after writing successfully	Set On/Off the designated bit address after successfully writing data to PLC.

Note

- The [write when button is released] option is not available on cMT / cMT X Series models.
- For safety, the options in the Option List displayed on the HMI have a minimum protective height of 7mm to prevent accidental touches.

13.29.2.1. Source of item data

- **Predefine**

The list is manually defined in [Mapping] tab.

The number of items can be adjusted by [Item no.], and each item represents one state. Each item has a corresponding value which will be written to [Monitor address].

- **Dates of historical data**

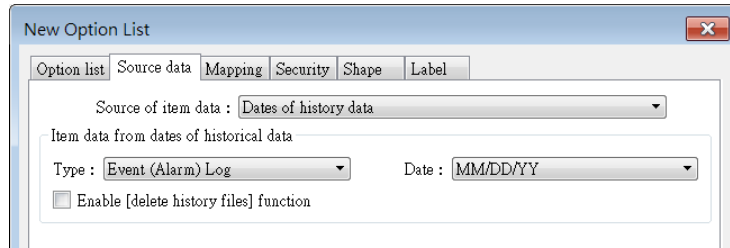

Option List object can be used with historical data display objects, such as Trend Display object, History Data Display object and Event Display object to control which history file should be shown. The figure below is an example of Option List used with Trend Display.

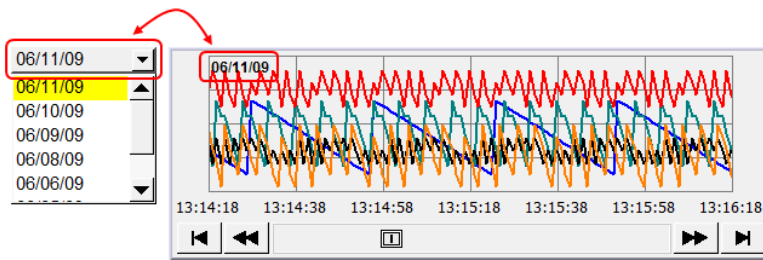

Setting	Description
Type	Two options are available: [Event (Alarm) log] and [Data sampling].
Date	Set the date format. YYYY means a four digits year (EX: 2012), YY means a two digits year (EX: 12), MM means month and DD means day.
Data Sampling	Select which Data Sampling object is displayed when [Type] is [Data Sampling], and it should be the same as the [Data sampling object index] configured in [Trend Display] or [History Data Display].
Enable [delete history data] function	If selected, a control address can be set. Writing "1" to this address will delete the history data of the specified date.

Note

- In [Dates of historical data] mode, since the system automatically reads the historical data and finds the date information, it is not necessary to configure in the [Mapping] tab.
- The error message displayed in Option List can be modified in [Mapping] tab.

Item	Value	Item data
▶ 0 (error)		Error!!

● **Item address**

The list will be read from the given [Item address] and controlled by [Control address]. The following options will be available:

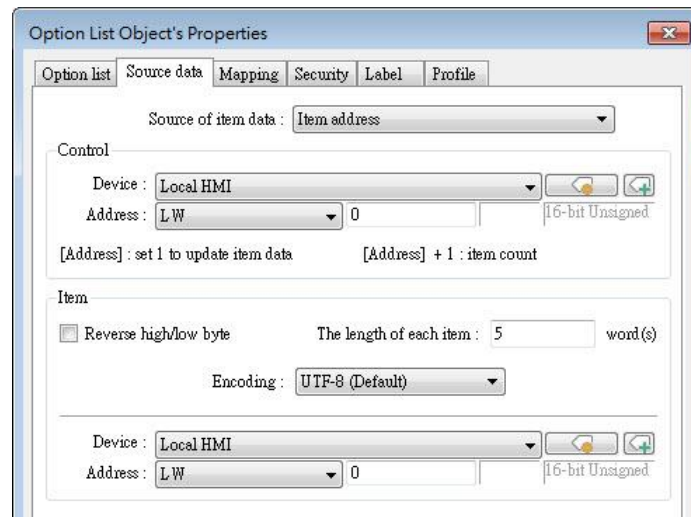

Setting	Description
Control	[Address]: If the value at this address is changed to 1, the option list would be replaced by items defined at [Item address]. After updating, the value will be restored to 0. [Address + 1]: Define the number of items in [Item address].
Item	Assign the item address UNICODE The item will use UNICODE characters, such as Chinese characters. The length of each item Define the number of letters for each item, the unit is Word.

Note

- The UNICODE characters used here should be used by Text object, so that EasyBuilder Pro will compile the needed fonts and download these fonts to HMI, then the UNICODE letters can be correctly displayed.
- [The number of items] multiplied by [The Length of each item] must be less than 4096 words.
- In [Item address] mode, the system automatically disables the settings in [Mapping] tab.
- After changing windows, the item address content will be removed. To retain it, use "Set when window opens" setting of Set Word object for automatic content update.

● User account

If [Enhanced Security] mode is enabled, [User account] would appear in the [Source of item data] and it lists the names of users.

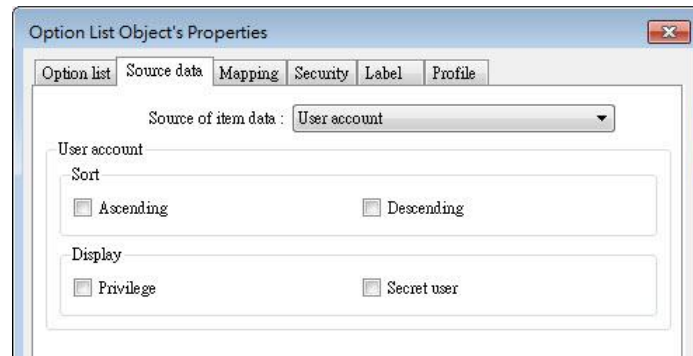

Setting	Description
Sort	Select the sorting method from [Ascending] of [Descending].
Display	If [Privilege] is selected, the privileges for each user will be displayed in option list. If [Secret user] is selected, even though it is defined to be hidden in [System parameter settings] » [Security] » [Enhanced Security], the users will still be displayed in [Option List].

Note

- The address that controls user index is [Control Address +2 (LW-n+2)] which is set in [System Parameters] » [Security] » [Enhanced Security].
- The [Privilege] option is not available on cMT / cMT X Series models.

Mapping Tab

This table displays all available states/items, their item data and values. To change the number of available items, please go to [Option list tab] » [Attribute] » [Item no.].

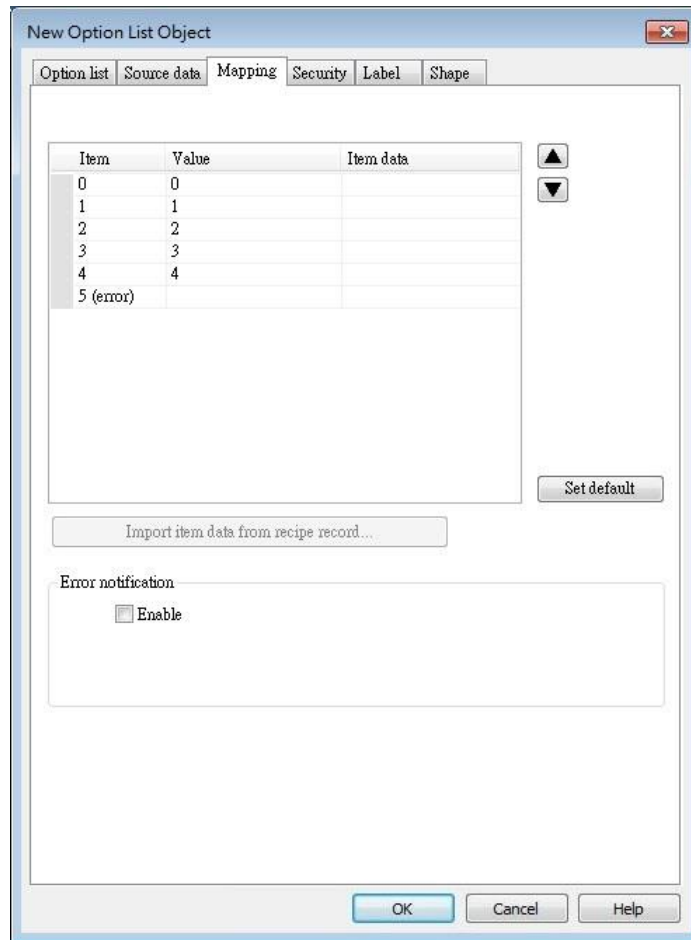

Setting	Description
Item	The system lists all available items. Each item represents a state that will be displayed in the list. This field is read-only.
Value	Here user can assign value for each item, basing on the following two criteria: For reading: If the value in [Monitor address] is changed, the object selects the first-matched item. If no item is matched, the status goes to error state and signals the notification bit register (if requested). For writing: The system writes this value to [Monitor address] when user selects an item.
Item data	Text displayed for each item. The Option List object displays the text of all items in the list for users to review and select.
Import item data from recipe record	This feature is enabled when select [Recipe-Selection] as [Monitor address]. Click [Import item data from recipe record] to open the [Records of Recipe Database] setting dialog box. Select [Item data source], the data belonging to the selected column will all be imported to Option List object.

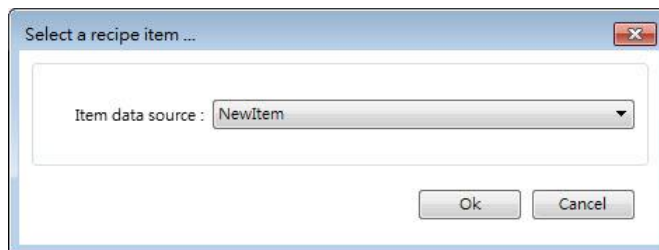

Before importing, the number of items in Option List changes according to the number of items defined in Records of Recipe Database.

After importing, modifying Records of Recipe Database will not change the content of Option List.

Error state	<p>On error state, the list box removes the highlight to represent no item is selected and the drop-down list displays the data of error state. Only the drop-down list uses error state, list box is not able to use error state.</p> <p>For example, item number 8 is the error state when specifying 8 in [Item no.]. (The first item number is 0)</p>
Set default	<p>Reset all values or states to default. That is, set 0 for item 0, 1 for item 1, and so on.</p>
Error notification	<p>The system will set ON/OFF to the specified bit register when error is detected. The signal of the bit register could be used to trigger a procedure for correcting the error by using objects such as Event Log, Alarm Bar, or pop-up window.</p>

13.30. Timer

13.30.1. Overview

Timer object can be used to count the time in a specified mode. Timer object uses the following 6 variables:

Timer Variable	Type	Description
Input bit (IN)	Bit	The main switch of Timer.
Measurement bit (TI)	Bit	Turns ON when the Timer begins counting time.
Output bit (Q)	Bit	Activated when the Timer finishes counting time.
Preset time (PT)	Word	Presets a time before the Timer begins counting time.
Elapsed time (ET)	Word	Displays the elapsed time.
Reset bit (R)	Bit	Resets the elapsed time (ET) to 0.

Timer (Per-page): The Timer can be placed in a project window and be activated only in that window.

Timer (Global): Regardless of which window is displayed on HMI, the Timer starts counting time when the Input bit is in ON state.

13.30.2. Configuration



Click [Object] » [Time-related] » [Timer] icon on the toolbar to open the property dialog box as shown in the following figure.

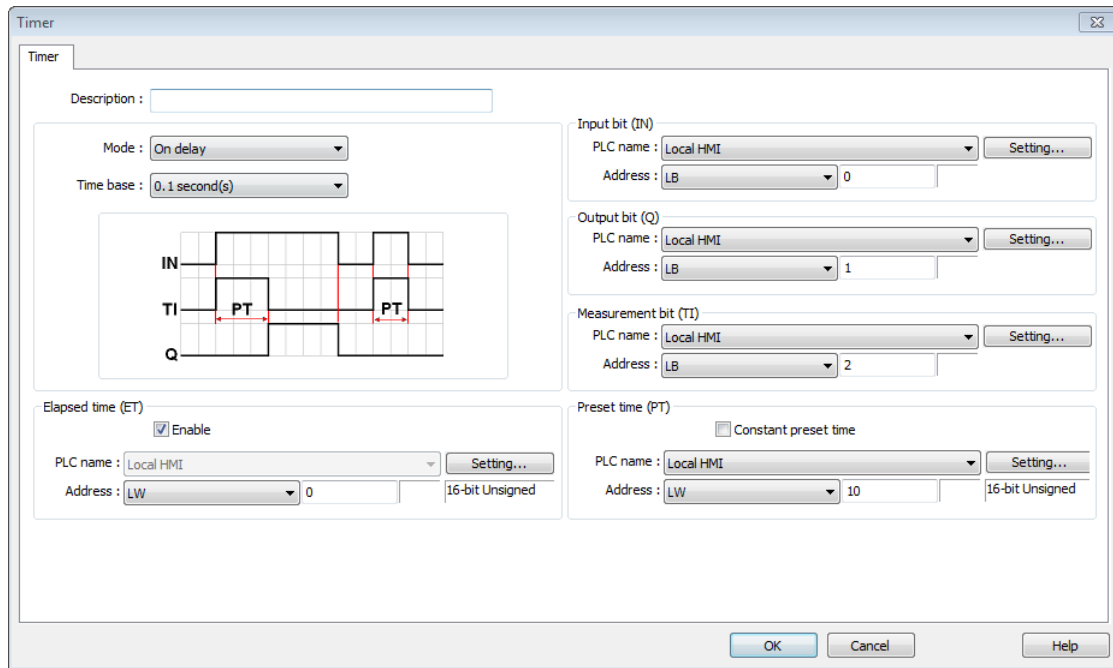

Note

- [Constant preset time] is only available for cMT / cMT X series.
- In a cMT / cMT X project, after the [Timer (Global)] icon is clicked, a Timer management window opens in which timers can be added by clicking [New].

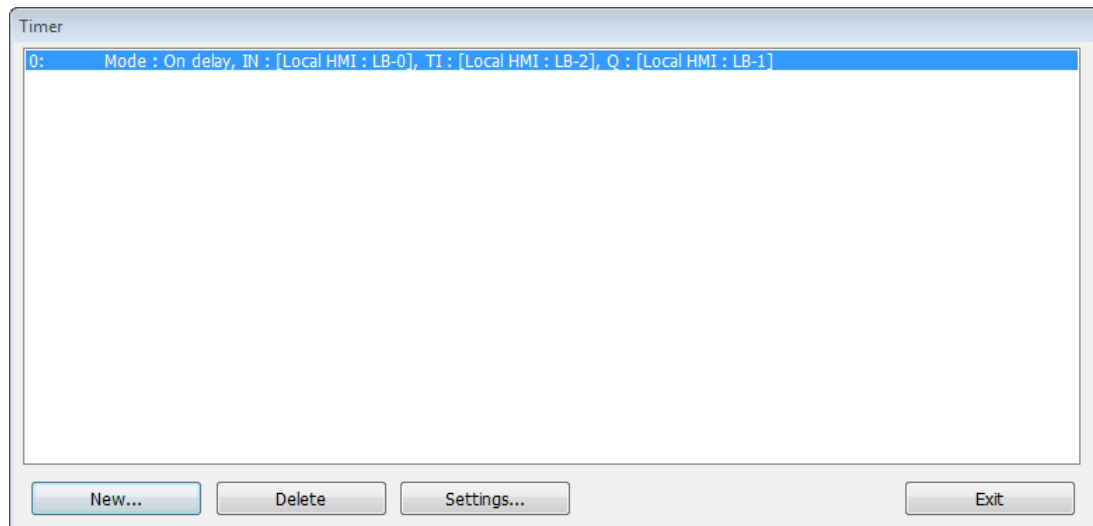

● On delay

Mode	Register
	<p>Input bit (IN): The main switch of Timer.</p> <p>Measurement bit (TI): Turns ON when the Timer begins counting time.</p> <p>Output bit (Q): Turns ON when the Timer finishes counting time.</p> <p>Preset time (PT): Presets a time before the Timer begins counting time.</p> <p>Elapsed time (ET): Displays the elapsed time.</p>
Description	
<p>Period 1: When the IN turns ON, TI turns ON and the ET starts counting. The Q remains OFF.</p> <p>Period 2: When the ET equals to the PT, the TI turns OFF and the Q turns ON.</p> <p>Period 3: When the IN turns OFF, the Q turns OFF and the ET is reset to 0.</p> <p>Period 4: When the IN turns ON, the TI turns ON and the ET starts counting. The Q remains OFF.</p> <p>Period 5: Turns IN OFF before the ET reaches the PT, the TI turns OFF, and the ET is reset to 0. Since the ET doesn't reach the PT, the Q remains OFF.</p>	

● Off delay

Mode	Register
	<p>Input bit (IN): The main switch of Timer.</p> <p>Measurement bit (TI): Turns ON when the Timer begins counting time.</p> <p>Output bit (Q): Turns OFF when the Timer finishes counting time.</p> <p>Preset time (PT): Presets a time before the Timer begins counting time.</p> <p>Elapsed time (ET): Displays the elapsed time.</p>
Description	
<p>Period 1: When the IN turns ON, the TI remains OFF and the Q turns ON, the ET is reset to 0.</p> <p>Period 2: When the IN turns OFF, the TI turns ON and the Q remains ON, the ET starts counting.</p> <p>Period 3: When the ET equals to the PT, the Q and TI turn OFF.</p> <p>Period 4: When the IN turns ON, the TI remains OFF and the Q turns ON, the ET is reset to 0.</p> <p>Period 5: When the IN turns OFF, the TI turns ON and the Q remains ON, the ET starts counting.</p> <p>Period 6: Turns the IN to ON before the ET reaches the PT, the TI turns OFF, the Q remains ON, and the ET is reset to 0.</p>	

● Pulse

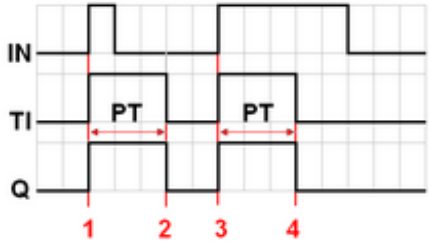
Mode	Register
 <p>The diagram shows four periods of operation. In each period, the Input bit (IN) transitions from OFF to ON. At this point, the Measurement bit (TI) and Output bit (Q) both turn ON. A horizontal double-headed arrow labeled 'PT' indicates the duration of the pulse. When the elapsed time reaches the preset time (PT), TI and Q turn OFF. When IN turns OFF, TI and Q remain OFF until IN turns ON again.</p>	<p>Input bit (IN): The main switch of Timer.</p> <p>Measurement bit (TI): Turns ON when the Timer begins counting time.</p> <p>Output bit (Q): Turns ON when the Timer begins counting time and turns OFF when the Timer finishes counting time.</p> <p>Preset time (PT): Presets a time before the Timer begins counting time.</p> <p>Elapsed time (ET): Displays the elapsed time.</p>
Description	
<p>Period 1: When the IN turns ON, the TI and Q turn ON simultaneously, and the ET starts counting.</p> <p>Period 2: When the ET equals to PT, the TI and Q turn OFF simultaneously. Since IN is turned OFF when counting time, the ET is reset to 0.</p> <p>Period 3: When the IN turns ON, the TI and Q turn ON simultaneously, and the ET starts counting.</p> <p>Period 4: When the ET equals the PT, the TI and Q turn OFF simultaneously.</p>	

● Accumulated ON delay

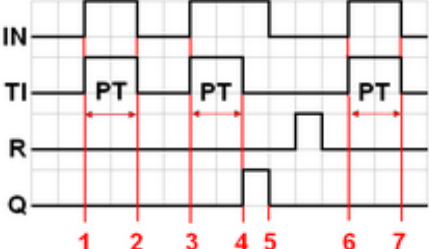
Mode	Register
 <p>The diagram shows seven periods. IN turns ON at period 1, 3, and 6. In period 1, TI turns ON and ET starts counting. In period 2, IN turns OFF. If ET < PT, TI turns OFF and ET is retentive. In period 3, IN turns ON, TI turns ON, and ET starts counting from its previous value. In period 4, ET reaches PT, TI turns OFF, and Q turns ON. In period 5, IN turns OFF, Q turns OFF, and R turns ON. In period 6, R turns OFF, and in period 7, IN turns ON, TI turns ON, and ET starts counting from 0.</p>	<p>Input bit (IN): The main switch of Timer.</p> <p>Measurement bit (TI): Turns ON when the Timer begins counting time.</p> <p>Output bit (Q): Turns ON when the Timer finishes counting time.</p> <p>Preset time (PT): Presets a time before the Timer begins counting time.</p> <p>Elapsed time (ET): Displays the elapsed time.</p> <p>Reset bit (R): Resets ET to 0</p>
Description	
<p>Period 1: When the IN turns ON, the TI turns ON and the elapsed time ET starts counting, the Q remains OFF.</p> <p>Period 2: When the IN turns OFF, if the ET doesn't reach the PT, the TI turns OFF, and at the same time the Q remains OFF. The ET is in the retentive state.</p> <p>Period 3: When the IN turns ON, the TI turns ON. The timer measurement starts again and the ET starts counting from the kept value. The Q remains OFF.</p> <p>Period 4: When the ET reaches the PT, the TI turns OFF and the Q turns ON.</p> <p>Period 5: When the IN turns OFF, the Q turns OFF. Turning ON the reset bit R will reset the ET to 0, and then the reset bit turns OFF.</p>	

● **Accumulated OFF delay**

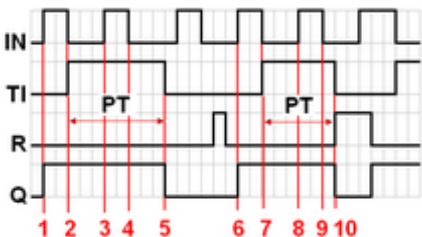
Mode	Register
	<p>Input bit (IN): The main switch of Timer.</p> <p>Measurement bit (TI): Turns ON when the Timer begins counting time.</p> <p>Output bit (Q): Turns OFF when the Timer finishes counting time.</p> <p>Preset time (PT): Presets a time before the Timer begins counting.</p> <p>Elapsed time (ET): Displays the elapsed time.</p> <p>Reset bit (R): Resets ET to 0</p>
Description	
<p>Period 1: When the IN turns ON, the TI remains OFF and the Q turns ON.</p> <p>Period 2: When the IN turns OFF, the TI turns ON and the Q remains ON. The ET starts counting.</p> <p>Period 3: When the IN turns ON, the TI and Q remain ON, and the ET is in the retentive state.</p> <p>Period 4: When the IN turns OFF again, the ET starts counting from the kept value.</p> <p>Period 5: When the ET equals to the PT, the TI and Q turn OFF simultaneously. Turning ON the reset bit R will reset the ET to 0, and then the reset bit turns OFF.</p>	

13.31. Video In

13.31.1. Overview

HMI provides the video In feature that enables users to monitor sites with cameras. The images/video can also be stored in external devices for further analysis. Sampling applications include site monitoring, or vehicle/building surveillance...etc.

The following tables show the video input and image capturing behaviors for different models.

Model		iP	iE	eMT	mTV	XE	cMT-SVR	cMT-FHD cMT-FHDX cMT-HDM	Other cMT/cMTX
Supported device type	IP Camera	N/A	N/A	Y	N/A	Y	N/A	Y	Y
	USB Camera	N/A	N/A	Y	Y	Y	N/A	Y	Y
	Video Input	N/A	N/A	eMT3121A eMT3151A	N/A	N/A	N/A	N/A	N/A

Model	Non-cMT Series – Image Capture	cMT / cMT X Series – Image Capture/ Video Recording
Image Capturing	IP Camera	Image Capture: one image is captured at the trigger moment. Video Recording: video is recorded, for a pre-determined duration, around the trigger moment.
	USB Camera	
	Video Input	Several images are captured around the trigger moment.

13.31.2. Configuration



Click the Video In icon on the toolbar to open the property dialog box. Set up the properties, press OK button, and a new Video In object will be created.

General Tab

eMT, iE, XE, mTV Series

Video Input

New Video In (USB Camera)

General

Comment: _____

USB Camera IP Camera Video Input

Encode format: NTSC

Capture

Enable

Device: Local HMI

Address: LB 0

Storage medium

USB disk SD card

Record time

Before: 1 seconds After: 1 seconds

Control

Enable

Display adjustment

Device: Local HMI

Address: LW 0 16-bit Unsigned

Start/stop input: LW-0

Contrast adjustment: LW-2

Bright adjustment: LW-3

OK Cancel Help

USB Camera

New Video In (USB Camera)

General

Comment: _____

USB Camera IP Camera Video Input

* [USB Camera] can only be used in landscape (horizontal) mode.

* Set LB-12356 to enable web streaming, and then use web browser to view live video from USB camera. Note that [Video input (USB camera)] cannot be used at the same time.

Capture

Enable

Device: Local HMI

Address: LB 0

Storage medium

SD card

Control

Enable

Device: Local HMI

Address: LW 0 16-bit Unsigned

Start/stop input: LW-0

Pause: LW-1

* [USB Camera] with [Pause Control] requires OS version 20170214 or later.

OK Cancel Help

IP Camera

New Video In (USB Camera)

General

Comment: _____

USB Camera IP Camera Video Input

RTSP:// _____

Streaming over TCP

Capture

Enable

Device: Local HMI

Address: LB 0

Storage medium

USB disk SD card

Control

Enable

Dynamic RTSP URL

Device: Local HMI

Address: LW 0 16-bit Unsigned

Start/stop input: LW-0

Pause: LW-1

RTSP: LW-2 (64 words)

* URL will be reloaded from RTSP address after object restarts.

* [IP Camera] requires OS version 20160411 or later.

OK Cancel Help

cMT, cMT X Series

USB Camera

IP Camera

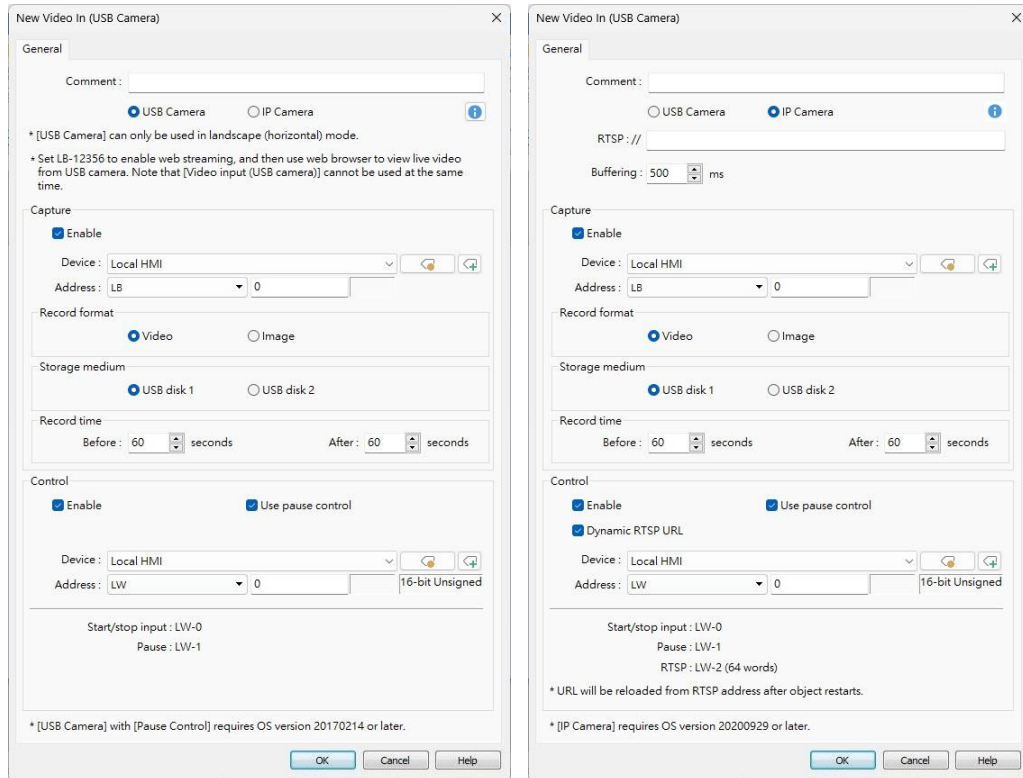

Setting	Description
Input channel	Select the Video Input channel from channel 1 or channel 2. (Analog video systems)
Encode format	Select the format from NTSC or PAL. (Analog video systems)
RTSP	Enter the IP camera's RTSP address. When account and password are required for accessing the IP Camera, an RTSP address with credentials embedded can be used. For example: admin:admin@192.168.1.119:554/cam/realmonitor?channel=1&subtype=0
Streaming over TCP	Select this check box to stream video over TCP.
Buffering	This setting allows adjustment of the buffering time between 200 milliseconds and 5 seconds to provide more stable video playback when the network is unstable.
Capture address	Select [Use capture function] check box and configure the settings. A non-cMT model can capture images while a cMT / cMT X model not only can capture images but also can record an avi video from n seconds before to n seconds after the triggering time of the

designated address.

Capture address

Designate the address that triggers image capturing.

Storage medium

Designate the storage device.

Information about storage type and input type:

Input Type	Storage Type
Analog Input	SD card or USB disk.
USB Camera	SD card only. Exception: cMT3092X
IP Camera	SD card or USB disk.

Record time (cMT / cMT X Series)

The camera records the video from and to the specified recording time (n seconds before and after the triggering time of the designated address). The video is then saved to the specified storage device. Please note that after the video is recorded, the HMI may take a while to compress the video. The time needed for compressing the video may differ between models depending on CPU performance. A red dot appears in the object indicating that recording or compressing is in progress. The HMI will not record the next video during compression.

Record time (eMT Series)

Set a period of time to capture the images.

System	Method
Analog video system	<ul style="list-style-type: none"> ● The longest period can be set from 10 seconds before triggering [Capture address] to 10 seconds after triggering. ● The time interval of image capturing is once every second. ● The captured .jpg file will be named in the following format: Before or after [Capture address] is triggered: YYYYMMDDhhmmss.jpg The moment that [Capture address] is triggered: YYYYMMDDhhmmss@.jpg <p>For example, set [Record time] "Before" and "After" to "5" seconds. When the state of [Capture address] changes from OFF to ON, the system will start capturing one image per second, from 5 seconds</p>

	before the triggering time to 5 seconds after the triggering time, which is 11 images in total including the one captured at the triggering moment.
USB Camera	Only the image of the triggering moment is captured. The name format: YYYYMMDDhhmmss.png.
IP Camera	Only the image of the triggering moment is captured. The naming format: YYYYMMDDhhmmss.png.

Control address

If enabled, enter certain value to the control address and the following addresses can control Video Input object. For example, if the designated control address is LW-n (n is any address), enter certain value to the designated addresses will execute commands as the following table.

Analog Video Systems

Address	Value	Command
LW-n	0	Stop displaying image
	1	Open channel 1 and display the image on HMI
	2	Open channel 2 and display the image on HMI
	3	Open channel 1 but don't display the image on HMI (Capture function operable)
	4	Open channel 2 but don't display the image on HMI (Capture function operable)
LW-n+1	1	Pause / resume the video
LW-n+2	1~100	Adjust the contrast ratio (Analog video systems only)
LW-n+3	1~100	Adjust the brightness (Analog video systems only)

USB Camera / IP Camera

Address	Value	Command
LW-n	0	Stop displaying image
	1	Start displaying image
LW-n+1	1	Pause / resume the video
LW-n+2	string	RTSP address for IP camera (64 words)

- After changing the value in [Control address (LW-n)], the

system will keep the new value.

- After changing the value in [Control address + 1 (LW-n+1)], the system will execute the command and then reset the value to 0.
- If [Use control function] check box is not selected, the system will play the image of the selected channel.
- If [Display adjustment] check box is selected, the contrast ratio and brightness can be adjusted. (Analog video systems)



Note

- Only one channel can be opened at a time, regardless of the type of camera used.

About analog video systems:

- Real-time images can still be captured when Video In is paused.
- Recommended analog video systems and resolutions:

	1:1	50%
NTSC	720 x 480	360 x 240
PAL	720 x 576	360 x 288

About cMT / cMT X Series Video Recording

- Compressing the recorded video may take a period of time depending on the video length.
- When HMI is compressing a video, it will not record new video even if the designated address is triggered.

About USB Camera:

- USB camera cannot be viewed on cMT Viewer.
- When the USB Camera is disconnected during video playing, video will not resume when camera is connected again. If [Control address] is used in the project, please use the control address to stop and restart video. If [Control address] is not used, switch to another screen and then return, or restart HMI in order to resume the video.
- The maximum size of Video In object of eMT3070A is 340*240, as for eMT3105P, eMT3120A, eMT3150A, XE, and mTV Series, the maximum size of Video in object is 640*480.
- When using a USB Camera, the display resolution of the run-time video is determined by the resolution supported by the USB Camera that is closest to the size of the object. The resolution supported by the USB Camera may not be identical to the size of the object. Therefore, it is good practice to adjust the size of object according to the actual resolution of the video.
- When using a USB Camera, the right and bottom edge of the Video In object will keep a distance of 50 pixels away from the window edge to prevent the run-time video from exceeding the window.
- When using a USB Camera, the background color of Video In object is black. If the resolution of the run-time video is smaller than the object, the empty area is colored black. Therefore, it is good practice to adjust the size of object according to the actual

resolution of the video. The tested and available USB Cameras are: Logitech C170, Logitech C310, Logitech C910, LifeCam VX-2000.

About IP Camera:

- Viewing IP camera on cMT Viewer may be possible on a Windows PC, provided that appropriate third-party codecs are used.
- As compatibility may vary, testing with an actual device is recommended.
- A RTSP address is required for using IP camera. The RTSP address can be found in the configuration tool of the IP camera, or possibly from an online repository.
- When the IP Camera is disconnected during video streaming, video will not resume when the camera is connected again. If [Control address] is used in the project, please use the control address to stop and restart video. If [Control address] is not used, switch to another screen and then return, or restart HMI in order to resume the video.
- When using an IP camera, the display resolution of the run-time video will be same as that of the object drawn in the EasyBuilder Pro project. If the actual video resolution is different from the size of the object, the resolution will be adjusted to fit the object, which may cause distortion of video image. Therefore, it is good practice to adjust the size of object according to the actual resolution of the video.
- Use the IP cameras that comply with ONVIF standard, and use RTSP for video streaming.
- To ensure the quality and smoothness of the video, and not to affect HMI's general performance, adjust the settings of IP camera when video lags or high CPU loading is observed. As the project complexity and hardware specs vary from one case to another, please fine-tune the video parameters accordingly.
- Recommended video specification:

Resolution	960x544 (max.)
Format	H.264, MJPEG
Refresh Rate	15 fps
Transmission Speed	800kbps (max.)

13.32. System Message

13.32.1. Overview

If objects use [Display confirmation request] or [local HMI supports monitor function only] is turned on/off, the corresponding messages configured here will be displayed in pop-up message boxes.

13.32.2. Configuration



Click the System Message icon on the toolbar to open the setting dialog box.

System Message

System Message

Confirmation required

Dialog size : Small Middle Large

Message : Use label library

OK : Use label library

Cancel : Use label library

Font :

Deny write-command

Message : Use label library

Font :

Allow write-command

Message : Use label library

Font :

Setting	Description
Dialog Size	Select the size for pop-up window and texts.
Confirmation required	If an object uses [Display confirmation request], this message would pop up when the object is used. [Message] shown on

confirmation dialog box, and the text label of the 2 buttons, [OK] and [Cancel], can be set. Please use the same font for the labels of [Message], [OK] and [Cancel]. Additionally, only when selecting [Label Library] for [Message], the use of Label Library for [OK] and [Cancel] buttons can be enabled.

Deny write-command

Displays when system tag LB-9196 (local HMI supports monitor function only) is turned ON.

Allow write-command

Displays when system tag LB-9196 (local HMI supports monitor function only) is turned OFF.

13.33. Recipe View

13.33.1. Overview

Recipe View object can be used to display a specific recipe. All items and values of the recipe can be viewed by using this object.

13.33.2. Configuration



Click the Recipe View icon on the toolbar to open a Recipe View object property dialog box. Set up the properties, press OK button, and a new Recipe View object will be created.

General Tab

cMT / cMT X Series

New Recipe View Object

General Security Shape Font

Comment :

Filter enabled
 Allow in-cell editing

Recipe table

Recipe name : 123

Item name	Display
1 NewItem	<input checked="" type="checkbox"/>

Default sort method

Enable

Sort by : NewItem

Ascending Descending

Style : Crystal Style color : [Blue]

Caption

Use caption

Font size : 16 Color :

Name	Color
Caption	Caption

OK Cancel Help

eMT, iE, XE, mTV Series

Recipe View Object's Properties

General Security Shape Font Profile

Comment :

Refresh data automatically

Recipe table

Recipe name : recipe

Default sort method

Enable

Sort by : A

Ascending Descending

Title

Transparent

Color : [Blue]

Profile

Transparent

Frame : [Blue] Background : [White]

Grid

Enable

Color : [Black]

Selection control

Color : [Blue]

OK Cancel Help

The name of each part of the Recipe View object is shown in the following figure.

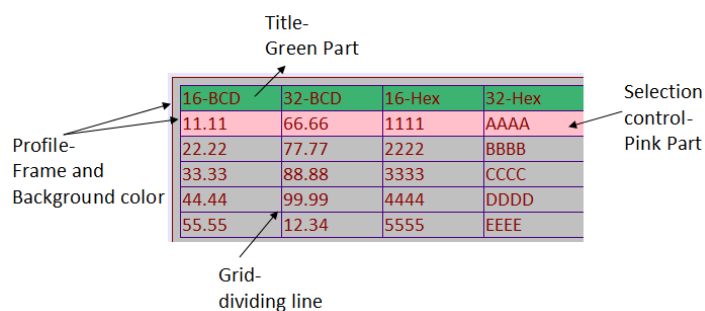

Setting	Description
Filter enabled	When selected, entering keywords in Recipe View to search for specific text is possible.
Allow in-cell editing	When selected, editing Recipe Database directly in Recipe View is possible.
Refresh data automatically	When selected, the system will automatically refresh Recipe View when recipe is changed; otherwise, Recipe View will be refreshed after window change.
Recipe table	<p>Recipe name Choose the recipe name or look for other recipes from the drop-down list.</p> <p>Display Choose an item to be displayed by selecting its checkbox.</p>
Default sort method	Configure how the items are sorted. [Ascending] and [Descending] can be selected.
Style (cMT / cMT X Series only)	Available styles are: Default, Crystal, and Flat.
Caption (cMT / cMT X Series only)	With [Use caption] enabled, the text, font size, color, and name of the caption can be specified. (Use caption is only available when the selected style is Crystal or Flat.)
Title	The item name assigned in [Data/History] » [Recipe Database].
	<p>Transparent If selected, the title row has no shading; the color selection is not available.</p>
Profile	The frame and background color of the object can be set.
	<p>Transparent Select to hide the background, the color selection is not available.</p>
Grid	The dividing lines between columns and rows.
	<p>Enable Select to show the grid.</p> <p>Auto fit short column (cMT / cMT X Series Default style) The column width automatically adjusts to the size of the content.</p>

Selection Control

Shading color of the selected row.

Note

- There are 4 system registers that can be used to view/update/add/delete recipe database:

Selection

Current selection of record in Recipe View object, and it is numbered from zero. If the first record is chosen, the value of Selection will be 0. When the value of Selection is changed, the corresponding values will be updated, such as "No", "Timer_1", "Timer_2", as shown in the following figure.

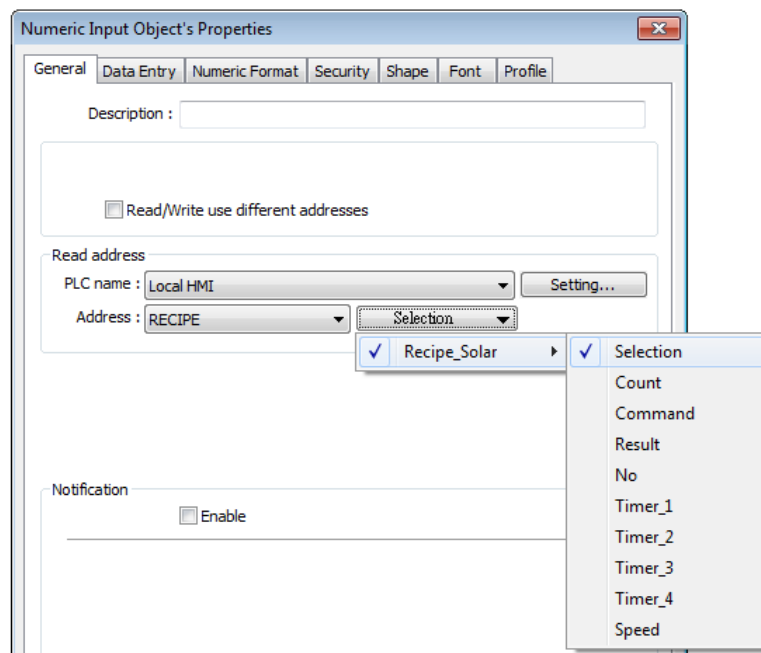

Count

Show the number of records in current recipe.

Command

Enter certain value will send command to the selected record.

Enter "1": Add a new recipe record.

Enter "2": Update the selected recipe record.

Enter "3": Delete the selected recipe record.

Enter "4": Delete all recipe records.

Enter "5": Write the selected recipe record to PLC.

Enter "6": Update the recipe record selected from PLC.

Result

View the result of executing commands.

Displays "1": Command successfully executed.

Displays "2": The selected record does not exist.

Displays "4": Unknown command.

Displays "8": Records reach limit (10000 records), no new records can be added.

Display "16": Another command is being executed.

Display "32": Transfer command failed.

 Please go to [Data/History] » [Recipe Database] tab to create the recipe data before using Recipe View object. See "24 Recipe Editor".

Example 1

In this example, a recipe database is created to be displayed by Recipe View object. When you select a recipe record on Recipe View object, the value of [Selection] and the corresponding values will change accordingly. When finish designing, you can modify the recipe database by entering a value in [Command].

Simple Recipe View & Recipe Database

No	Name	Timer_1	Timer_2	Timer_3	Timer_4	Speed
0	Mercury	10	1	11	12	28.500
1	Venus	20	1	21	22	33.500
2	Mars	30	2	32	35	41.500
3	Jupiter	50	3	53	56	50.500
4	Saturn	80	5	85	90	60.500

System Registers:
 Selection: Count: Command: Result:

Selected records: (modify here)

No. Name:

Timer_1: Timer_2: Timer_3: Timer_4: Speed:

Edited by Mac

1. Create a recipe as shown in the following figure.

The screenshot shows the 'Recipe Database' dialog box with the 'Definition' tab selected. It contains a 'Recipes List' table with the following data:

Item name	Data type	Size	Display width	Decimal Pt.	Alignment
No	16-bit Unsigned	1	5	0	Left
Name	ASCII	10	8	0	Left
Name_1	32-bit Signed	2	8	0	Left
Name_2	32-bit Signed	2	8	0	Left
Name_3	32-bit Signed	2	8	0	Left
Name_4	32-bit Signed	2	8	0	Left
Speed	32-bit Float	2	8	3	Left

Buttons: Import..., Export..., New, Delete, Settings...

Prohibit recipe database update from remote HMI (or set LB-12363 on)

* At most 100 items in one recipe are recommended. More items might reduce the performance of HMI.

Buttons: OK, Cancel, Help

2. In Data tab create a number of records as shown in the following figure.

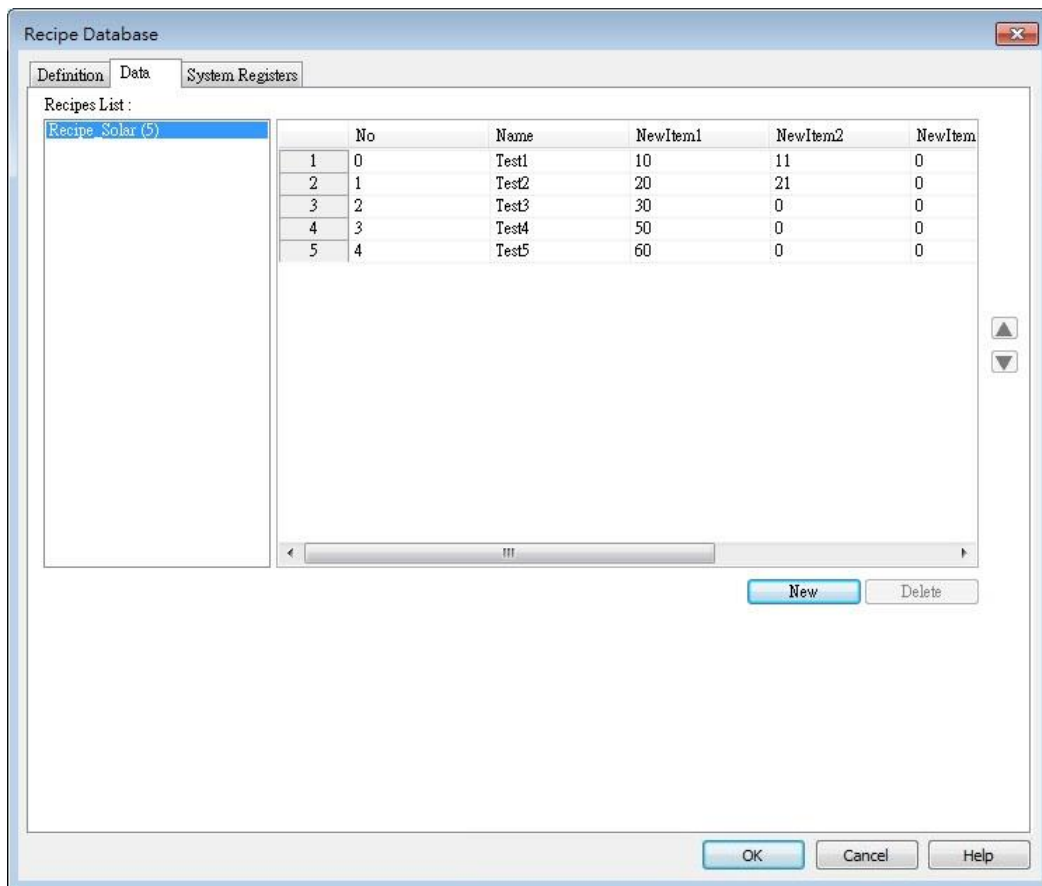

3. Create a Recipe View object and use the recipe database created in the preceding steps.
 4. Create 4 Numeric objects using registers "Selection", "Count", "Command", and "Result".
 5. Create corresponding input objects for "No", "Name", "Timer_1", ..., "Timer_4", "Speed". For example, "Name" is an ASCII item with size "10". Create an ASCII object and set device type to "RECIPE" » "Name".

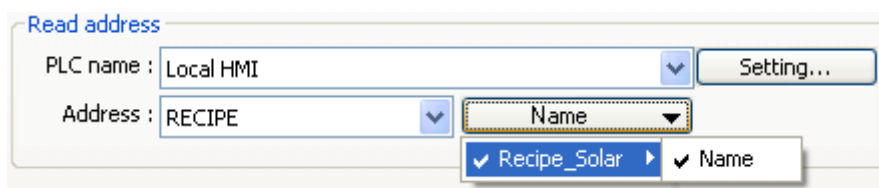

6. The project is then completed.
 7. As shown above, "Mars" is selected and the corresponding items are also updated. There are 5 records so the "Count" displays "5". Try selecting different rows of the Recipe View object. Fields "Name", "Timer_1", ...will change accordingly.
 8. Try the following operations:
- Add:
To add current data as a new record, enter "1" in "Command".
 - Update:
To update recipe database, enter "2" in "Command".

- Delete:
To delete the selected record, enter “3” in “Command”.
- Sort the items.
- Click the title to change the order.

Example 2

In this example, [RECIPE_Bit] can be used to read / write individual bits of Recipe data. Although BOOL type items cannot be added to Recipe Database, individual bit access of 16bit / 32bit data is possible.

As shown in the following figure, select [RECIPE_Bit] for the read address of Bit object and point to the target item, and then the available Bit selections will be displayed. In this manner, Recipe Database can be used to record, read, and write bit data.

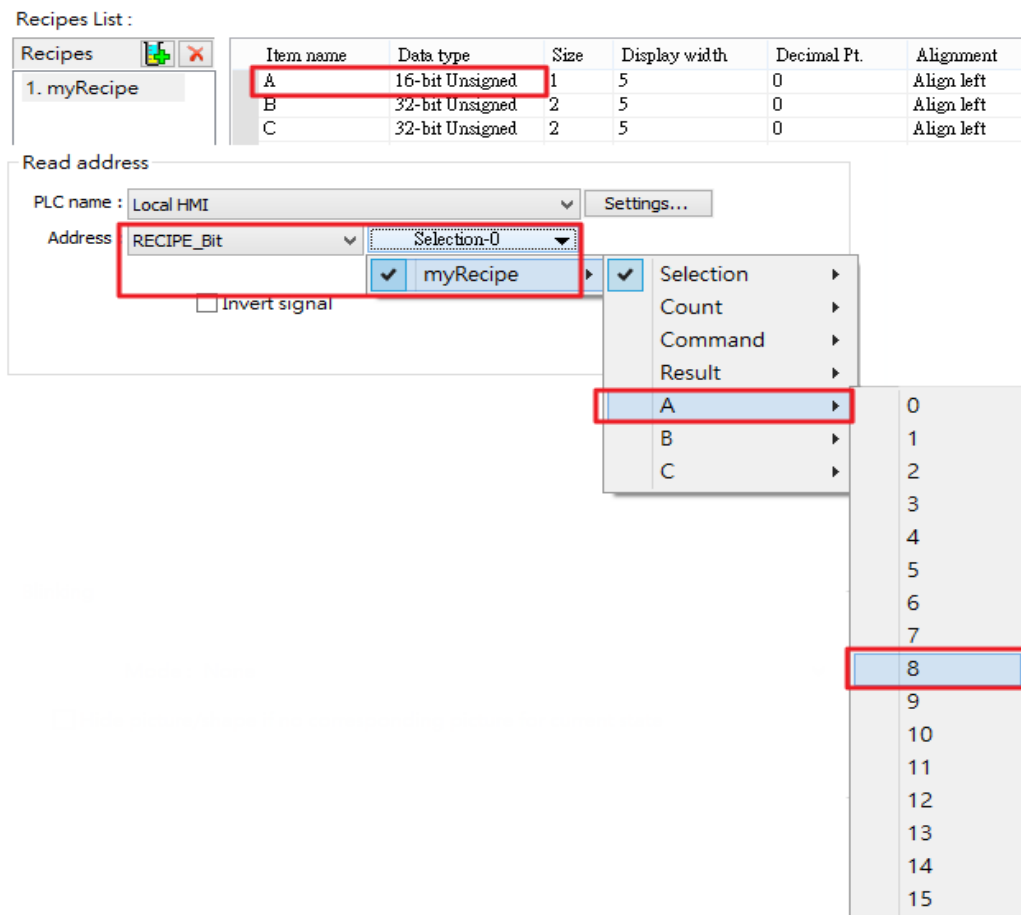

13.34. Flow Block

13.34.1. Overview

Flow Block object displays the flow status of the blocks in the pipe or the status of the transportation lines. Unlike Moving Shape object which requires a precise measurement between two points when drawing a straight line provided by users, the blocks flow at a fixed interval in a horizontal or vertical straight line. For cMT / cMT X Series models, drawing non-horizontal and non-vertical lines is possible.

The features of Flow Block:

- Each section of the Flow Block must be a horizontal or vertical straight line and the blocks flow at a fixed interval within it. For cMT / cMT X Series models, drawing non-horizontal and non-vertical lines is possible (angle limit: 5 degrees).
- Dynamic speed and direction adjustment (Speed and direction can be controlled by a designated register).
- Security mechanism (Interlock), which hides Flow Block when the status of designated bit is invalid.

13.34.2. Configuration



Click on the Flow Block icon on the toolbar or select [Objects] » [Animation] » [Flow Block] to create object.

General Tab

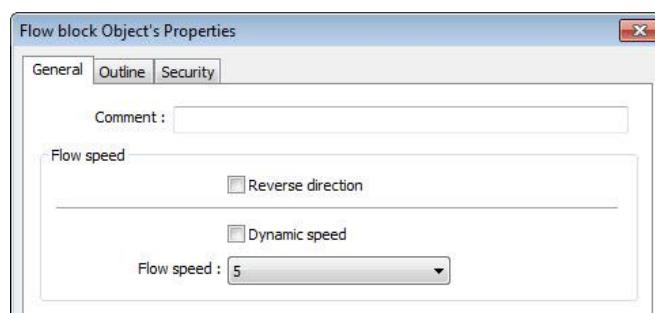

Setting	Description
Reverse direction	The blocks flow in the direction the object is drawn (the blue arrow). If select this check box, the blocks flow in the opposite direction.

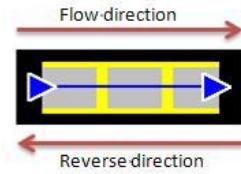



Dynamic speed	<p>Read address</p> <p>The direction and speed at which the blocks flow can be controlled by a designated register. The valid range is -25 to 25. When a negative value is entered, the blocks flow in a reversed direction.</p> <p>Setting</p> <p>Displays the address and format of the designated register. [System register], [Index register], and [Tag Library] can be set here.</p>
Flow speed	<p>25 flow speed levels, the valid range is 0 to 25 when [Dynamic speed] is not selected. A larger value indicates a faster speed.</p>

Outline Tab

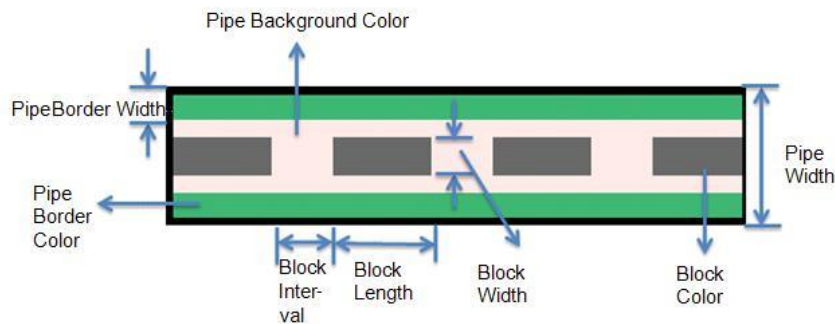
For setting the outline property of Flow Block. The following illustration shows each item.

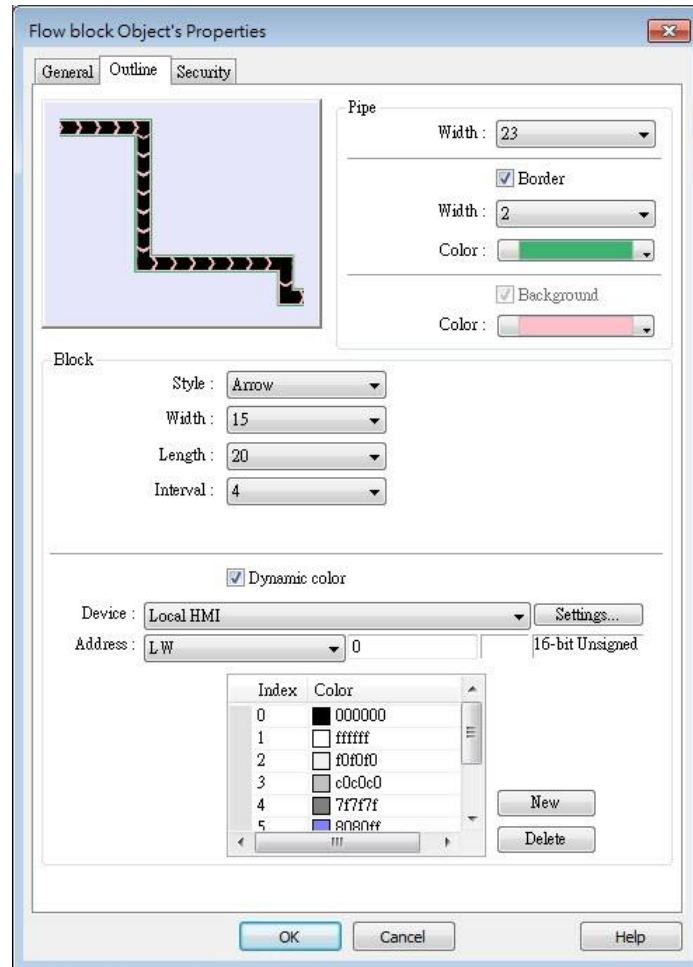



Setting	Description
Pipe	Sets the properties of the pipe within which the blocks flow. The background color, border width and color can be set. When the [Border] check box is selected, the background color must be set.
Block	Sets the properties of blocks. Style, width, length, interval and color can be set. Available styles are Rectangle and Arrow. The direction in which the arrows point to indicates the direction of the flow block. Rectangle:  Arrow: 
Dynamic color	Allows dynamic color change with 256 customized colors, numbered from 0 to 255 allowed. The color is selected by entering a value in the designated register. Entering a value greater than the largest color number changes the Flow Block to the last color in the list.

 **Note**

- If both [Reverse direction] and [Dynamic speed] check boxes are selected in [General] tab,

when entering a negative value in the designated register of dynamic speed, the blocks flow in the direction the object is drawn.

- When both [Arrow] and [Dynamic speed] are selected, the arrow will only show when a value is given to the designated address.
- To avoid the pipe lines from overlapping when drawing a turn, there is a minimum width planned at each turn. As shown in Fig. 34.1, the sign on the cross cursor defines the minimum width. Fig. 34.2 demonstrates that each turn is drawn in the minimum width.

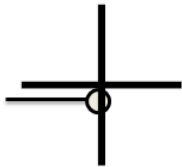

(Fig. 34.1)



(Fig. 34.2)

The valid range of the length, width, and height of the Flow Block can be adjusted according to the size of the object drawn and the size of the window.

As shown in the following figure, when the size of the Flow Block is larger, the valid range is restricted to prevent the flow block from exceeding the window size. When the size of the object is smaller, the adjustment range will be larger.

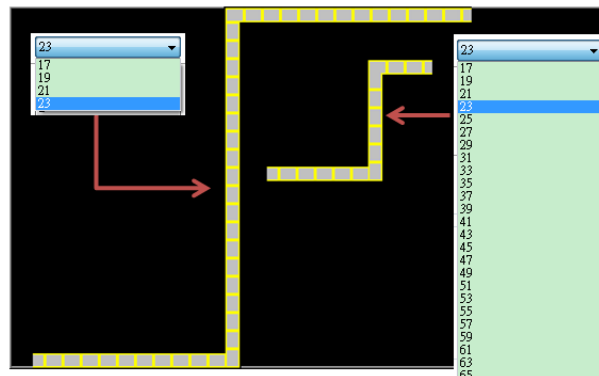

To prevent the flow block from overlapping itself, when the distance between two lines is shorter (Section A), the valid range is restricted. When the distance is longer (Section B), the adjustment range will be larger.

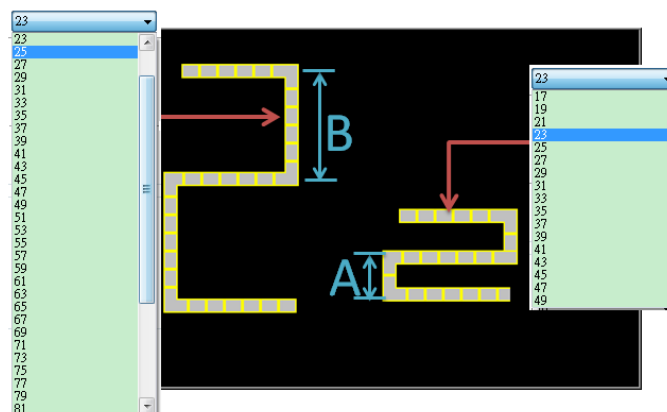

Example 1

The demonstration below shows how to use [Dynamic speed] to control the direction and speed of Flow Block by a designated word register.

1. Create a Flow Block object and select [Dynamic speed] check box. Set [Address] to LW-0, and set the format to 16-bit Signed.

The screenshot shows the 'Flow block Object's Properties' dialog box with the following settings:

- General** tab selected.
- Flow speed** section:
 - Reverse direction
 - Dynamic speed
- Read address** section:
 - PLC name: Local HMI
 - Address: LW 0
 - Format: 16-bit Signed

2. Create a Numeric object, set [Address] to LW-0. The high limit is 25, and the low limit is -25. The format is 16-bit Signed.

The screenshot shows the Numeric object configuration dialog box with the following settings:

- Direct
- Dynamic limits
- PLC low: -25
- PLC high: 25
- Input low: -25
- Input high: 25

3. Execute simulation or download the project to HMI. When entering a positive value in LW-0, the blocks flow in the direction the section is drawn. A larger value indicates a faster speed. When a negative value is entered, the blocks flow in a reversed direction, and the smaller value indicates a faster speed. When 0 is entered, it stops flowing.

13.35. Operation Log

13.35.1. Operation Log Settings

13.35.1.1. Overview

Operation Log records user’s operation steps and displays the record in real-time. When an error occurs, use operation log to analyze the problem. The backup tables can be used to review the process in order to resolve the errors. Operation log, if configured properly, may also be used to satisfy the requirement for audit trail and electronic signature.

Date	Time	Class	Window	Object Name	Comment
03/05/13	18:17:47	full privilege	10	TS 0	A1 Power
03/05/13	18:17:46	full privilege	10	TS 0	A1 Power

13.35.1.2. Configuration



Select the objects to be recorded. Click [Data/History] » [Operation Log Setting], and then select [Enable operation log function] check box.

cMT, cMT X Series

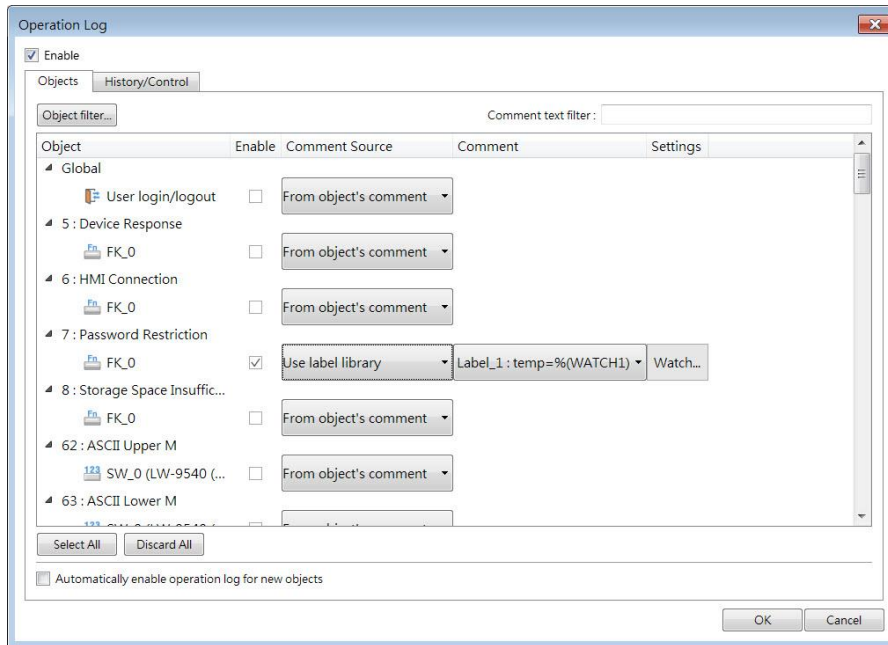

eMT, iE, XE, mTV Series

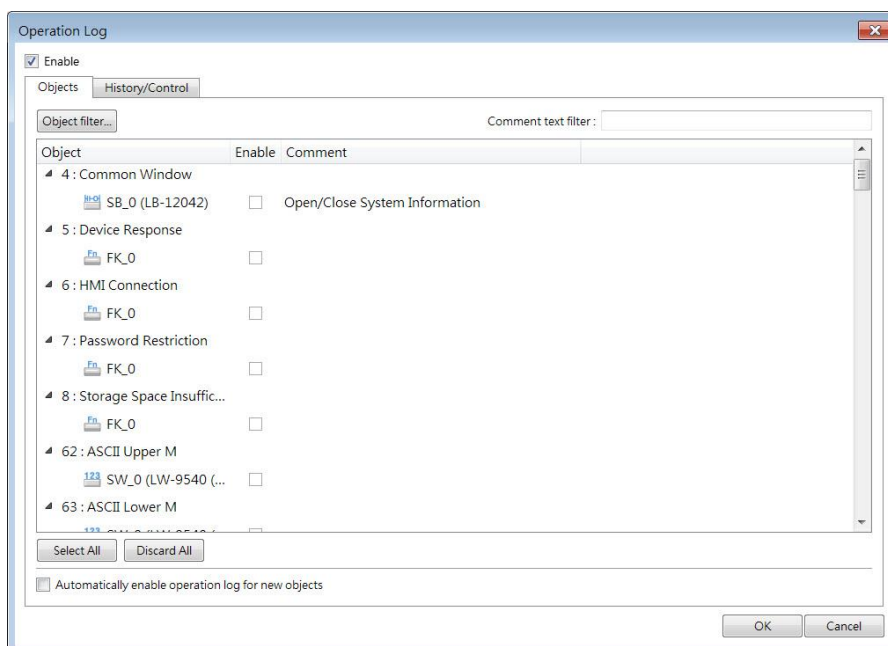

Objects

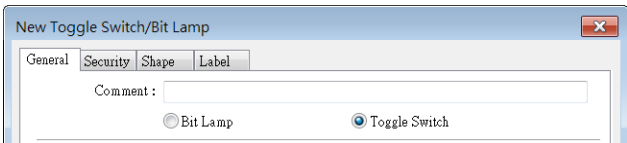
Setting	Description
Object	<p>With Operation Log function enabled, user login/logout activities and the objects that can be recorded are listed in the setting dialog box sorted by window numbers.</p> <p>[Filter]: By clicking [Object filter...], all recordable objects are listed. Users can use the filter to more easily locate the desired objects.</p>
Enable	The selected objects are recorded by Operation Log.
Comment Source	<p>From object's comment</p> <p>The content in the [Comment] field of the Operation Log is sourced from the object's comment setting.</p>  <p>Customize</p> <p>Users can customize the content in the [Comment] field of the Operation Log by clicking [Watch...].</p> <p>Use label library</p> <p>The [Comment] field supports the utilization of a label library, enabling the content to be recorded with translated text in different languages.</p>
Settings	<p>When the comment source is set to [Customize] or [Use label library], users can configure the watch addresses by clicking [Watch...]. When a label library is used as the comment source, the watch address syntax should be defined within the label content. Up to four addresses can be simultaneously watched.</p>

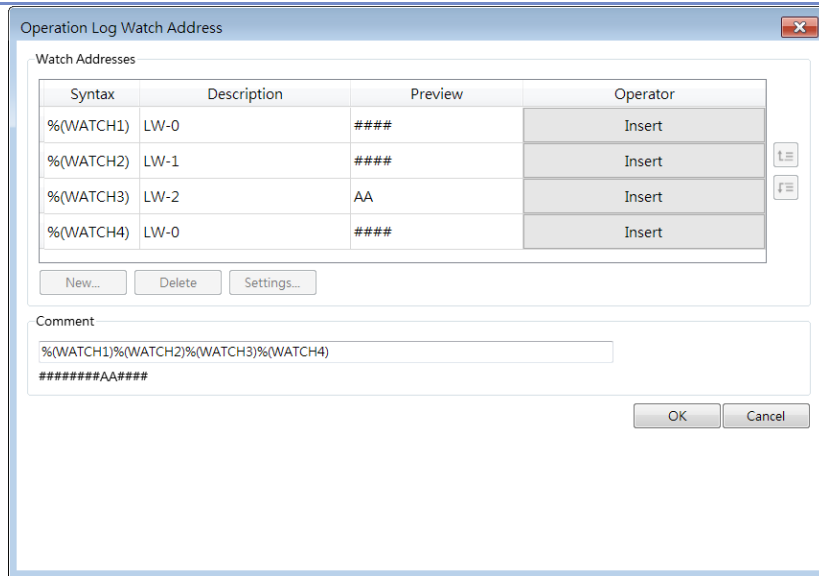

Select all Selects all the listed objects. If [Object filter] is used, clicking [Select all] only selects the objects in the list.

Discard all Discards all the selected objects. If [Object filter] is used, clicking [Discard all] only discards the objects in the list.

Automatically enable operation log for new objects With this option selected, new objects created will automatically be enabled for Operation Log.

History/Control

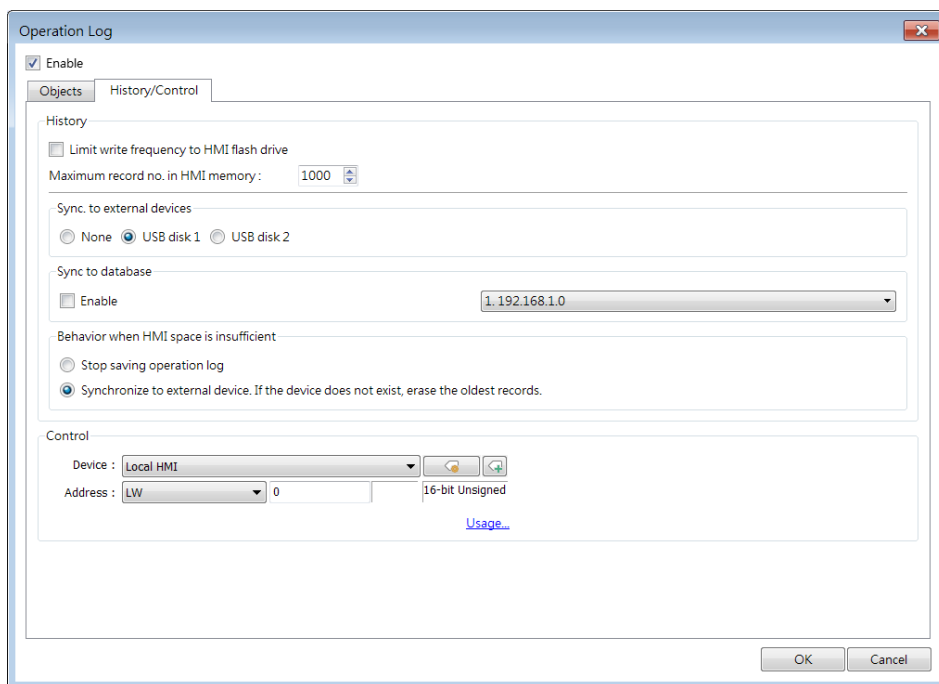

Setting	Description
Storage settings	<p>Sets the way the records are stored.</p> <p>Limit write frequency to HMI flash drive When enabled, the system will store operation logs on the HMI at intervals of 10 seconds. To prevent the loss of operation log data between two storage actions caused by power-off, EasyBuilder Pro provides the system register LB-9034. By sending an ON signal to this register, the system will initiate a data storage process.</p> <p>Maximum record no. in HMI memory Sets the maximum number of records that can be stored in HMI memory.</p> <p>Sync. to external devices / database Stores backup data to SD card or USB disk. Backup data can be synchronized to database (cMT / cMT X Series).</p> <p>Behavior when HMI space is insufficient When HMI memory space is insufficient, two options are provided: [Stop saving operation log]: Stops saving new records in order to keep the earlier records. [Synchronize to external device]: Stores the Operation Log to the external device. When the device does not exist, the HMI clears the oldest records in its memory.</p>
Control address	<p>Entering different values in the control address sends corresponding commands to Operation Log and returns the result of executing the command.</p> <p>If control address is LW-n (where n is an arbitrary number), the address that returns the result of executing the command is LW-n+1.</p> <p>Control address (LW-n):</p> <ul style="list-style-type: none"> (1): Clear all records. (2): Copy the records to the USB disk. (3): Copy the records to the SD card. (4): Copy the records to the USB disk and clear the records in HMI memory. (5): Copy the records to the SD card and clear the records in HMI memory. (6): Enable Operation Log. (7): Disable Operation Log. (8): Use history data stored in USB disk after changing HMI.

-
- (9): Use history data stored in SD card after changing HMI.
 - (10): Copy the records to the database server. (cMT / cMT X Series)
 - (11): Copy the records to the database server and clear the records in HMI memory. (cMT / cMT X Series)
 - (12): Use existing historical data in database after changing to another HMI. (cMT / cMT X Series)

Execution result (LW-n+1):

- (0): Processing.
 - (1): Execution succeeded.
 - (2): The device does not exist.
 - (3): The record does not exist.
 - (4): Unknown error.
-

Note

- Operation Log can only record the operation of the objects that are manually triggered. Objects that cannot be manually triggered are not recorded, such as Time Based Data Transfer object.
- When running off-line or on-line simulation, Operation Log is stored under EasyBuilder installation directory: HMI_memory\operationlog\operationlog.db
- Triggering Macro with a Set Bit object generates two records, the triggering of bit and the triggering of Macro.

13.35.2. Operation Log View

13.35.2.1. Overview

Operation Log View can be used to review the Operation Log.

13.35.2.2. Configuration



Before using Operation Log View, please follow the steps described in the preceding part to finish Operation Log Settings. Click [Data/History], and then click [Operation Log View].

General Tab

cMT, cMT X Series

eMT, iE, XE, mTV Series

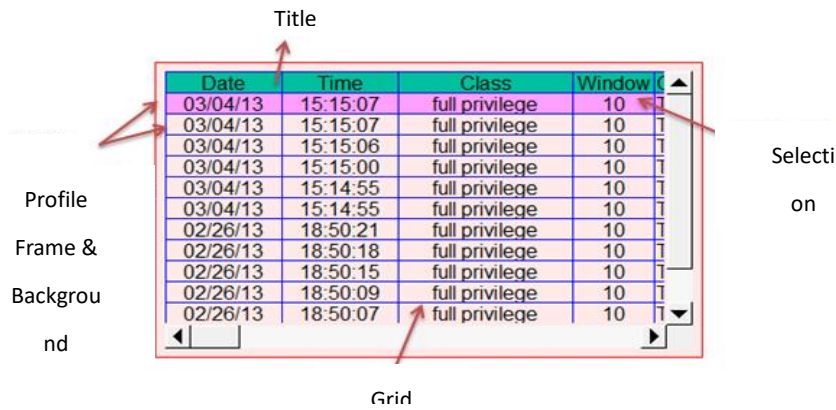
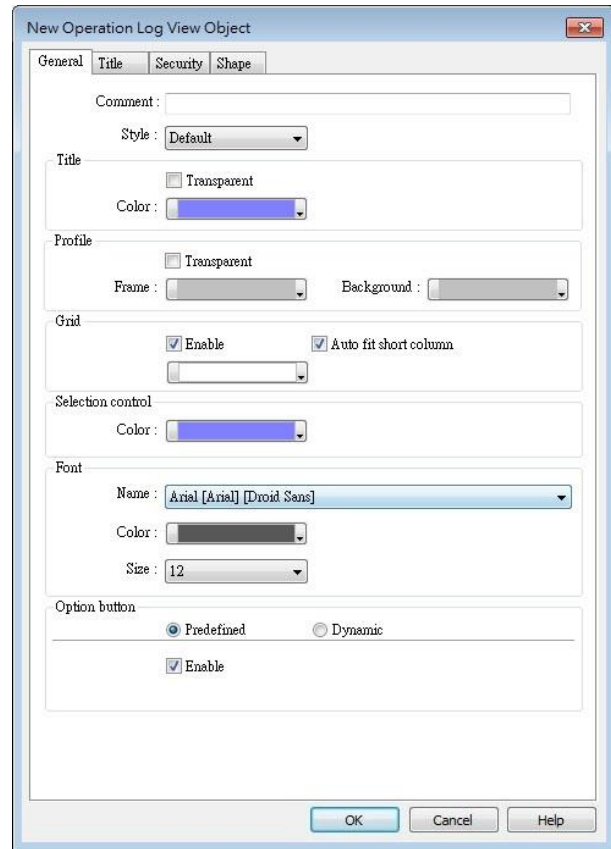
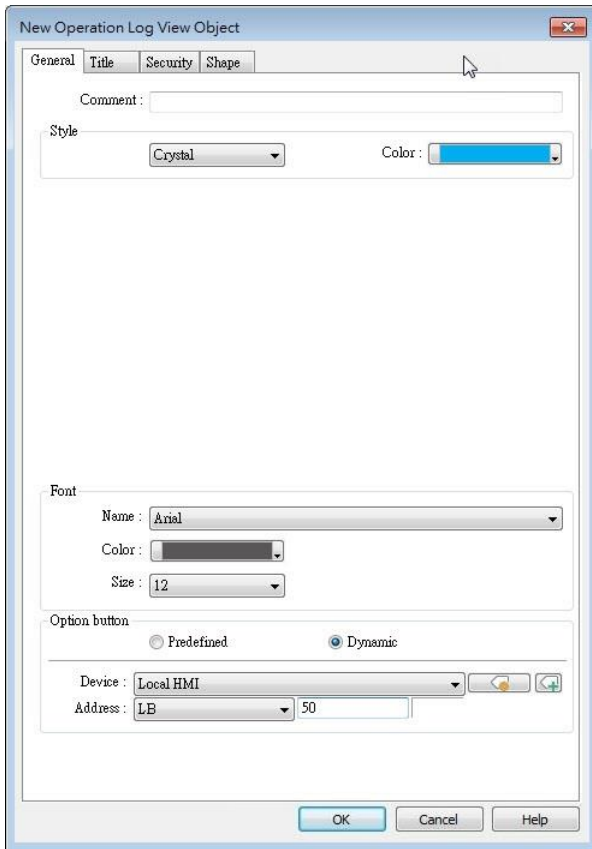

Setting	Description
Style	The style of Operation Log View object can be selected from Default, Crystal, and Flat.
Title/Profile/Grid/Selection control	These attributes can be configured when the chosen style is Default.
Font	Sets the color, font, and font size of the text displayed in Operation Log View object.

Option button visibility (cMT / cMT X Series)

Show or hide the option button .

Predefined

Select [Enable] to show the option button.

Dynamic

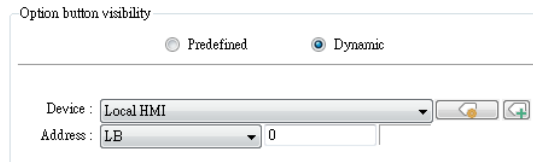

Designate a bit address to control option button visibility.

Title Tab

cMT, cMT X Series

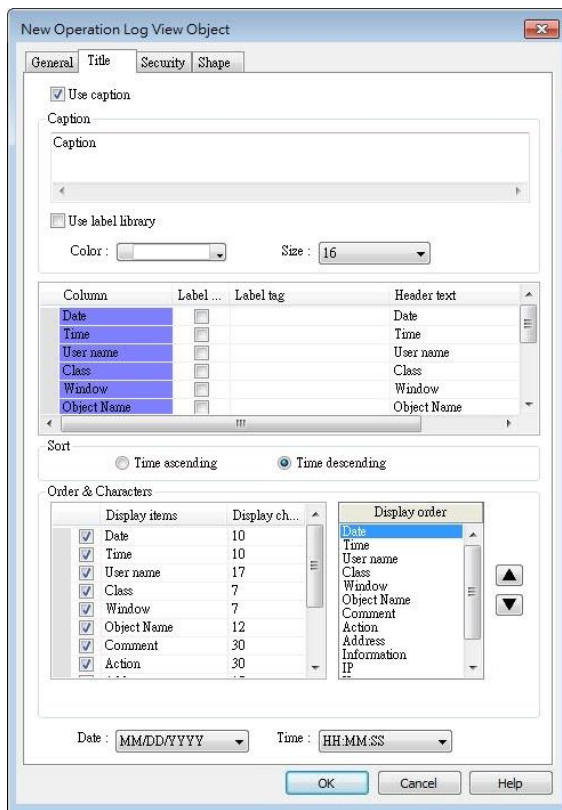

eMT, iE, XE, mTV Series

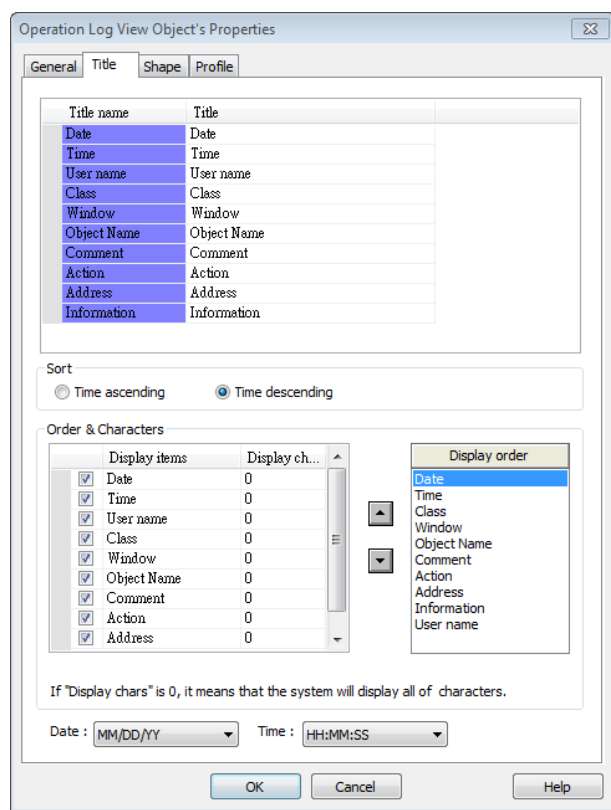

Setting

Description

Use Caption

Sets the caption displayed in Operation Log View object.

Title

Sets the title name of the columns displayed in Operation Log View object.

Sort

Sorts the records in time ascending or descending order.

Display order

Sets the order of the displayed item. If [Display chars.] is 0, all characters are displayed.

Date / Time

Sets the format of date and time displayed in Operation Log View

object.

13.35.3. Operation Log Printing

13.35.3.1. Overview

Operation Log Printing can generate an Operation Log sheet by printing out using a printer or by saving as JPEG/PNG/PDF file into an external device. Before using this function, please go to Operation Log Settings to finish the settings.

Operation Logs printed using cMT Viewer will be saved to the USB disk / SD card connected to the cMT / cMT X HMI.

13.35.3.2. Configuration



Select “Enable [Operation Log] printing” check box and click [Settings] button to open the Operation Log Printing dialog box.

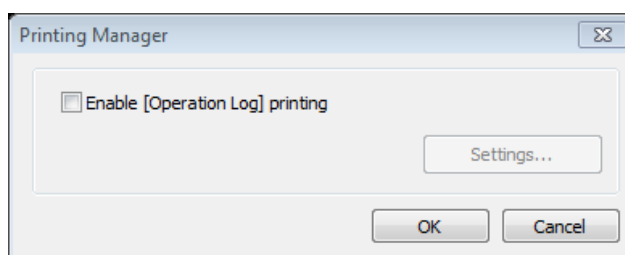

General Tab

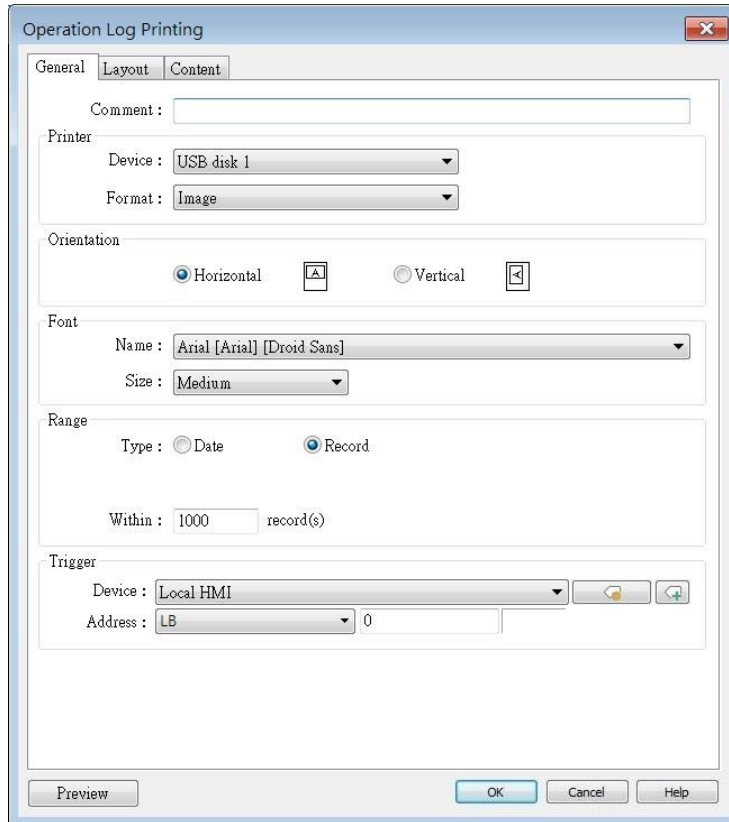

Setting	Description						
Printer	Select the device to save the Operation Log sheet. If a printer is selected, the paper size should be A4. If an external device is selected, the Operation Log sheet is saved as a JPEG / PNG file. The system generates a folder named "operationlogsheet", and the files saved in the folder are named " <i>print date_sequence number</i> ". For example, the first JPEG file saved on 2013/05/08 is named 130508_0000 and so on. Format Available formats include: [Image] and [PDF]. With [Image] selected, cMT/cMT X HMIs will generate PNG files, while other models will generate JPEG files. The [PDF] option is only supported on cMT/cMT X HMIs.						
Orientation	Sets the layout of the Operation Log sheet to be horizontal or vertical.						
Font	Sets the font and the font size to of the Operation Log sheet. The following table lists the corresponding size. <table border="1" data-bbox="496 1944 1121 2022"> <thead> <tr> <th>Size</th> <th>Title</th> <th>Content</th> </tr> </thead> <tbody> <tr> <td>Large</td> <td>20 pt.</td> <td>16 pt.</td> </tr> </tbody> </table>	Size	Title	Content	Large	20 pt.	16 pt.
Size	Title	Content					
Large	20 pt.	16 pt.					

	Middle	16 pt.	12 pt.
	Small	12 pt.	8 pt.

Range Sets the range of the Operation Log to be included in the sheet.

Date

Sets the range by date, counted from the start day through the number of days entered. The maximum available range is 180 days.

Record

Sets the range by the number of records. The maximum available range is 10000 records.

Trigger address Sets the register to control Operation Log Printing. When the register is set ON, it starts printing. When the printing is done, the register is set OFF automatically.

Preview Preview the result before generating the Operation Log sheet.

Layout Tab

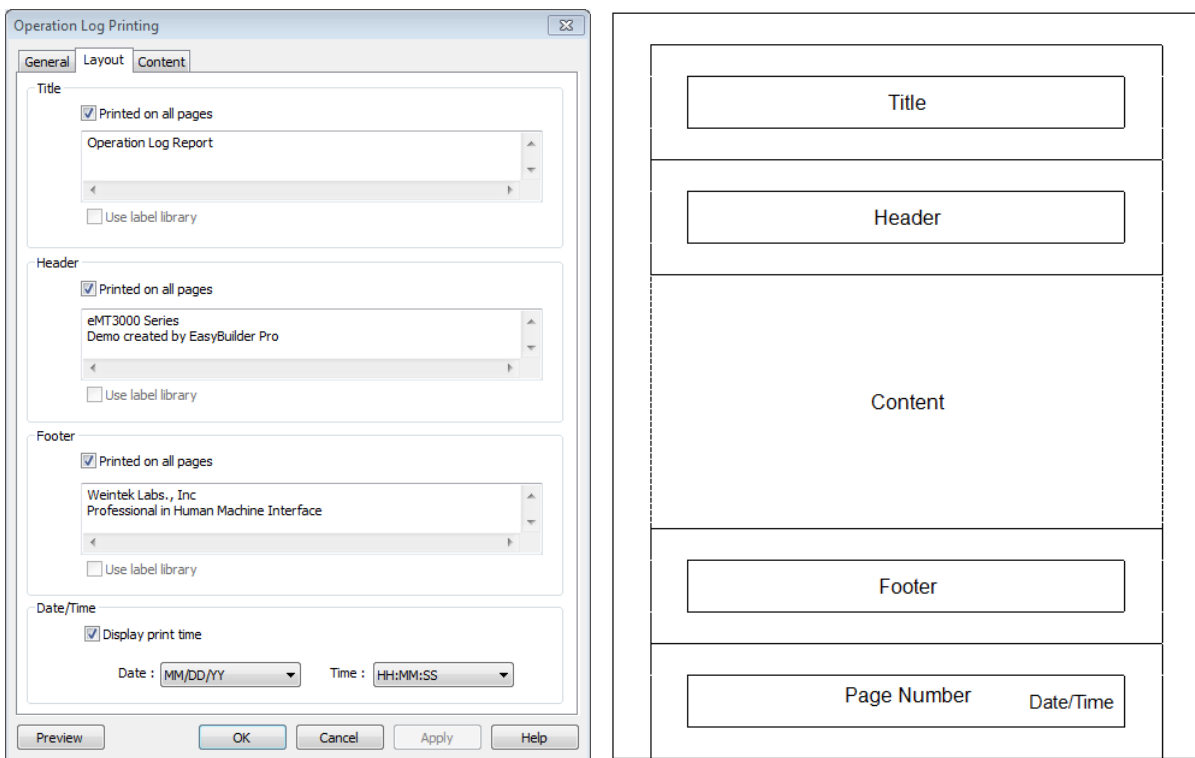

The layout of each part is shown in the above figure.

Setting	Description
Title	Sets the content of the title. The title is limited to one line. Printed on all pages If selected, the title is shown on each page; otherwise, the title is shown on the first page.
Header	Sets the content of the header. The header can have 5 lines in

maximum.

Printed on all pages

If selected, the header is shown on each page; otherwise, the header is shown on the first page.

Footer

Sets the content of the footer. The footer can have 5 lines in maximum.

Printed on all pages

If selected, the footer is shown on each page; otherwise, the footer is shown on the last page.

Date/Time

If selected, the date/time the in the sheet is shown on the lower-right corner of each page; otherwise, the date/time is not shown.

Page number

Shown on each page.

Content Tab

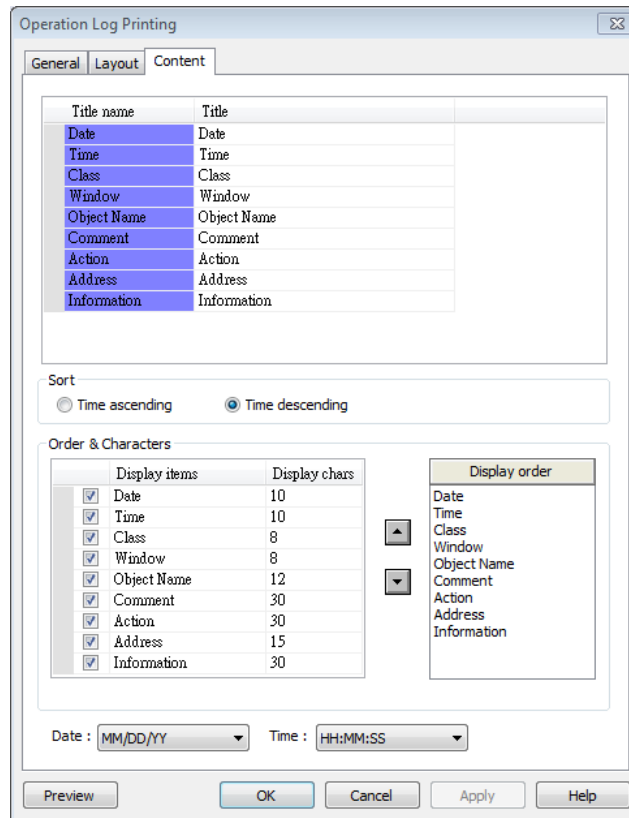

Setting

Description

Title

Sets the title displayed.

Sort

Time ascending

The latest record is placed at the bottom.

Time descending

The latest record is placed at the top.

Date/Time	Sets the format of date and time displayed.
------------------	---

13.35.3.3. Demonstration

Example 1

The following demonstration explains how to create an Operation Log project.

1. Create a Toggle Switch object and a Numeric object on window number 10.
2. Go to Operation Log Settings; enable the Toggle Switch object and Numeric object on window number 10.

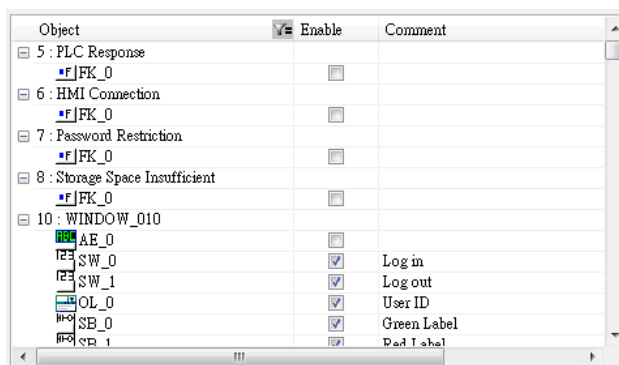

3. Create an Operation Log View object and finish relevant settings.
4. Run off-line simulation, trigger Toggle Switch and Numeric object. Operation Log is displayed by Operation Log View object.

Date	Time	Object ID	Action	Address	Information
04/05/17	13:48:22	TS 0	Toggle	Local HMI : LB-0	bit set OFF->ON
04/05/17	13:48:19	NE 0	Set word	Local HMI : LW-0	write 0->0

Example 2

Upload Operation Log to PC by using Utility Manager or use Backup object to send the file by email.

- Upload by Utility Manager
1. Open Utility Manager, click [Upload].
 2. Select [Operation log], enter file name and HMI IP, and then click [Upload].

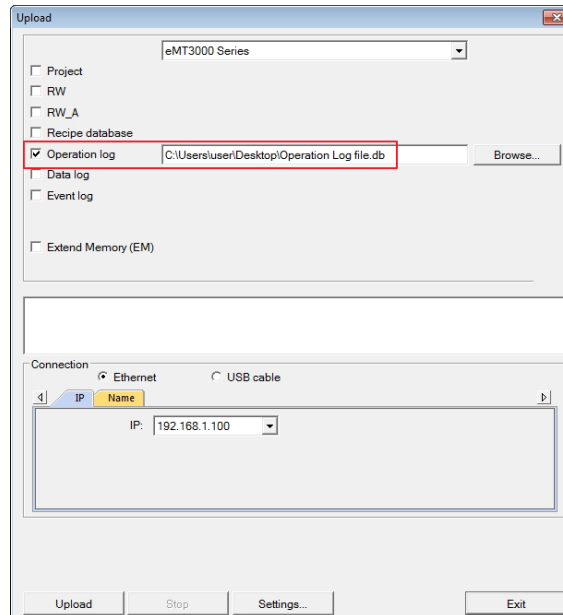

- Send the sheet by e-mail
- 1. Open [System Parameter Settings] » [e-Mail] tab. Set e-mail server and the address of recipient and sender.
- 2. Create a Backup object, under [Source] select [Operation log], and under [Backup position] select [e-Mail].

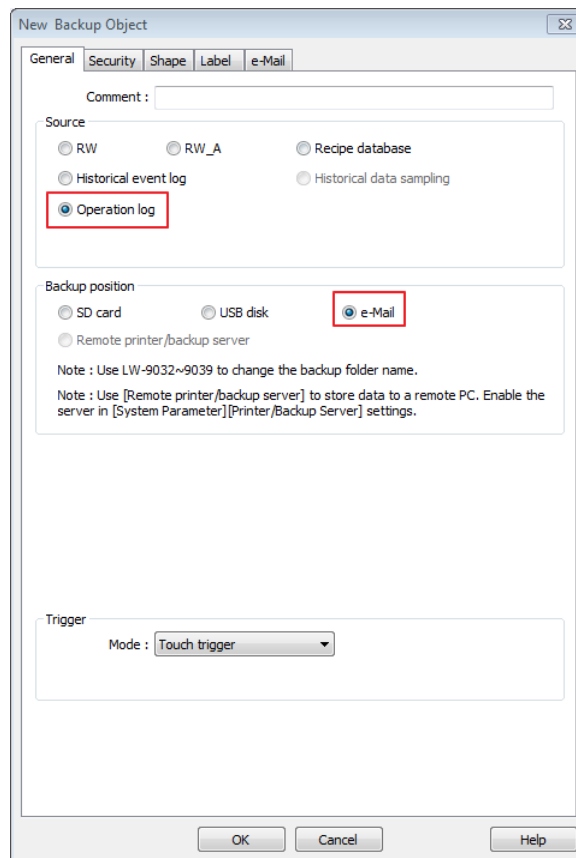

For more information about e-Mail settings, see “5 System Parameter Settings”.

13.36. Combo Button

13.36.1. Overview

Combo Button can execute multiple commands. The former way was to overlay multiple objects in the same position, and the commands are executed in the order of the layer of the objects. This takes time to test the order when planning the project. Combo Button allows users to easily set multiple commands with one object, and freely adjust the order of executing commands.

The following are the features of Combo Button:

- Executes multiple commands.
- Allows adjusting the order of executing multiple commands.
- Displays the state in Bit or Word Lamp.

13.36.2. Configuration



Click on the Combo Button icon on the toolbar or select [Objects] » [Combo Button] to create object. Configure object properties, click OK, a new Combo Button object will be created.

13.36.2.1. eMT, iE, XE, mTV

General Tab

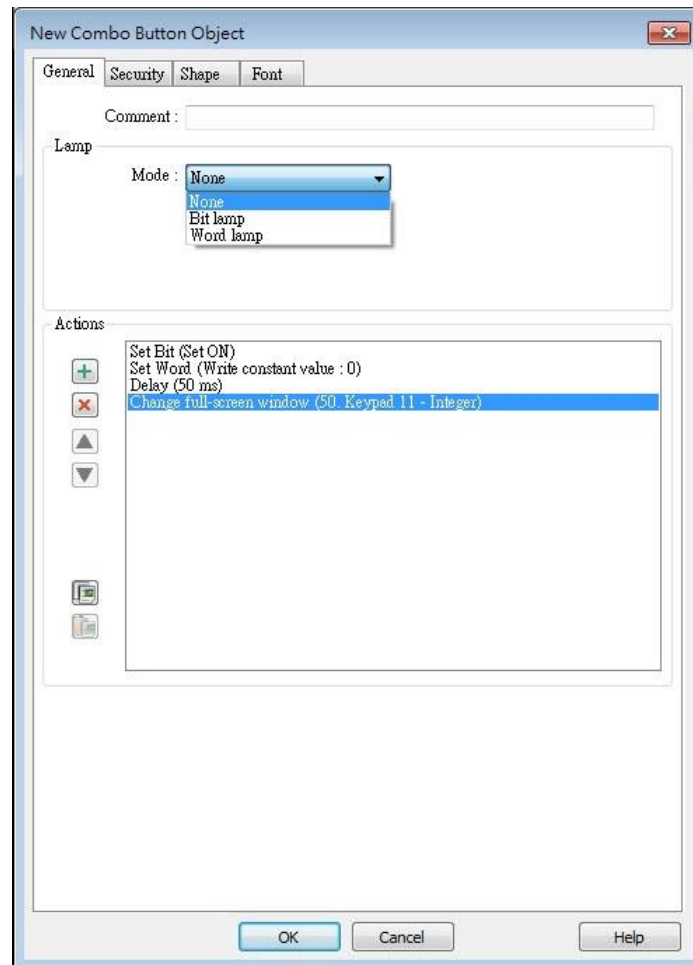

Setting	Description
Lamp	<p>The mode to display the state of a designated bit or word register.</p> <p>None: Not using lamps to show states.</p> <p>Bit Lamp</p> <p>Displays the state of a designated bit address.</p> <p>[Invert Signal] Reverses the display of ON / OFF states. For example, if [Invert signal] check box is selected, when the designated bit is OFF, the object displays ON state.</p> <p>Word Lamp</p> <p>Displays the state according to the value of a designated word register.</p> <p>[No. of state]: The number of states used by the object. The state is numbered from 0, so the number of states minus 1 will be the state number. If the value in the word register is \geq [No. of states] defined</p>

in Attribute, the highest state will be displayed.

If the number of states is set to 8, the valid states will be 0, 1, 2, ..., 7. In this case if the word value is 8 or higher, the system will display the state 7 shape.

[Change state by ranges]: Displays the state according to the range. When two ranges overlap, the state is determined by the priority. The priority is Default when the value is not within any range.

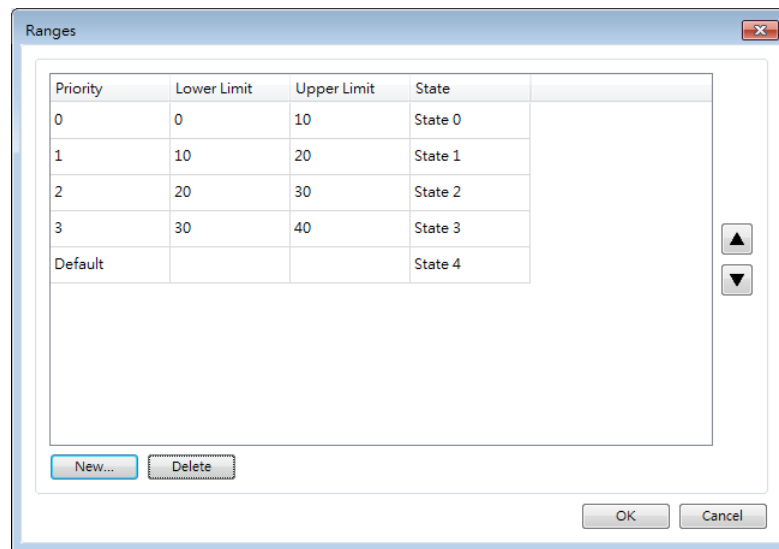

Actions

A combo button can execute up to 20 actions.

Key	Description
	Add actions.
	Delete the selected action.
	Change the order of the actions.
	Copy the selected action.
	Paste the copied action.

Add

Delay

Delays the action for a few milliseconds. A combo button can set one [Delay] action only.

Set Bit

Sets the designated bit ON or OFF.

Set style	Description
Set ON	Set ON the designated bit of the device.
Set OFF	Set OFF the designated bit of the device.
Toggle	Alternates the bit state each time pressed.

Set Word

Sets the value in the designated register.

Set style	Description
Write Constant Value	Writes a constant value to the designated register.
JOG+	Increases value in register by a set amount in [Inc. value] each time when the button is pressed, to the [Upper limit].
JOG-	Decreases value in register by a set amount in [Dec. value] each time when the button is pressed, to the [Bottom limit].
Dynamic limits	Sets the Upper / Bottom limit by a designated register. When Dynamic Address is LW-n, where n is an arbitrary number, set upper limit when using [JOG+], and bottom limit when using [JOG-].

Change Window

Switch to the designated window.

13.36.2.2. cMT / cMT X Series

General Tab

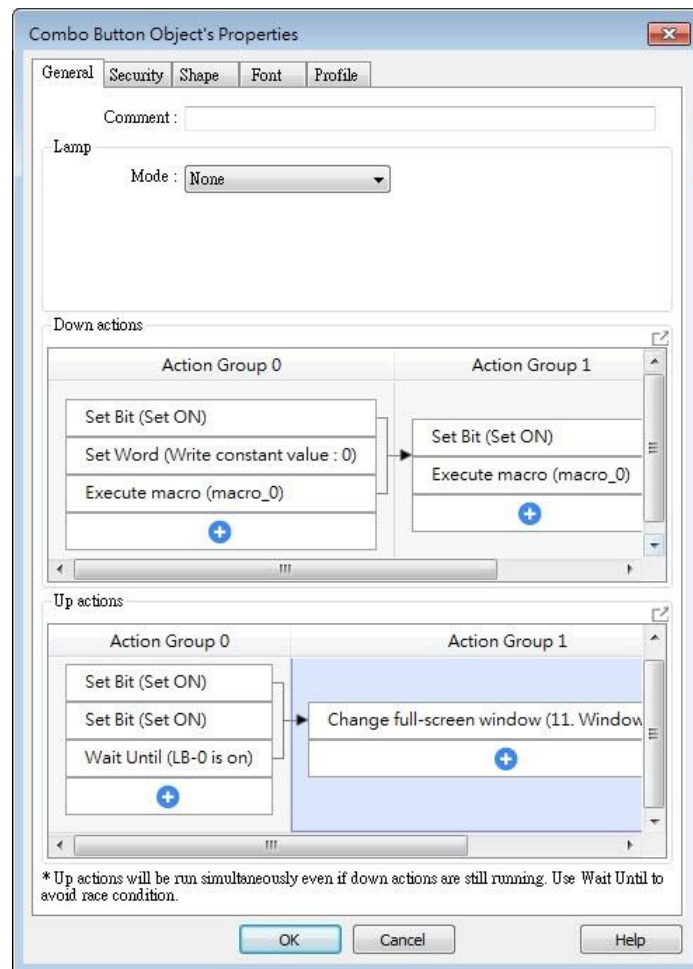

Bit/Word Lamp actions are explained in 13.36.2.1 eMT, iE, XE, mTV.

For cMT Series, actions can be classified into action groups, which are put in sequence. Actions within a group are executed at the same time, and after the actions in the current group have been all triggered, the actions in the next group will then be triggered. Please see Ch13.53 Action Trigger for more information on the notes about action groups.

Setting	Description
Down actions	Execute action when the button is pressed.
Up actions	Execute action after the button is pressed and released.
Delay	Delay action for the specified time (ms).
Set Bit	Sets the designated bit address ON or OFF. Set ON Sets ON the designated bit. Set OFF Sets OFF the designated bit.

	<p>Toggle Alternates the bit state.</p> <p>Momentary Momentary is a two-step action where pressing the button (Down action) will set the bit ON and then releasing the button (Up action) will set the bit OFF. Corresponding Down and Up actions will be created.</p>
<p>Set Word</p>	<p>Changes the value in the designated word address.</p> <p>Write constant value Writes the constant value to the designated register.</p> <p>Increment value (JOG+) Increases value in register by a set amount in [Inc. value], up to the [Upper limit].</p> <p>Decrement Value (JOG-) Decreases value in register by a set amount in [Dec. value], down to the [Bottom limit].</p> <p>Dynamic Limits (JOG+, JOG-) Sets the [Upper limit](JOG+) and [Bottom limit](JOG-) by a designated register.</p> <p>Write constant string Writes the constant string to the designated register.</p>
<p>Change window</p>	<p>Switches to the designated window.</p> <p>Change full-screen window: Changes to another base window.</p> <p>Change common window: Changes common window.</p> <p>Return to previous window: Changes from current screen to the previous one displayed. For example, when window no. 10 is changed to window no. 20, this function can be used to return to window no. 10. This function is only available for base window.</p> <p>Animation Setting: The effects are: Fade, Fly, Float, Wipe, Split, Circle, Clock, Zoom, Turn, Push. Different effects may be used for Start (window appears) and End (window disappears). [Duration] specifies how many milliseconds (ms) a transition effect takes to complete. [Direction] The direction of the transition.</p>
<p>Execute Macro</p>	<p>Executes one of the Macros from the drop down list that has already been configured by users. In an action group, [Execute Macro] is seen as completed as soon as it is triggered. Ever if a</p>

	particular macro takes longer to complete, the system will not wait for the macro to complete running before moving on to the next action group.
Popup Window	Opens a designated window.
Close Window	Closes currently opened window.
Popup Calculator Window	Opens a calculator with an unchangeable appearance, allowing operators to do simple calculation and enter the result to a destination object by pressing the Enter key.
Keyboard Input	<p>Configures the button as a keypad key, and the character it enters, via [Numeric] or [ASCII] objects.</p> <p>Enter: Same as the keyboard's "Enter" function.</p> <p>Backspace: Same as the keyboard's "Backspace" function.</p> <p>Clear: Clear the value in the word register.</p> <p>Esc: Same as the [Close window] function; it is used to close the keyboard window.</p> <p>Delete: Same as the keyboard's "Delete" function, deletes the number or character on the right side of the text cursor.</p> <p>Left: Same as the keyboard's "←" key moves the text cursor to the left side of the previous number or character.</p> <p>Right: Same as the keyboard's "→" key moves the text cursor to the left side of the next number or character.</p> <p>Inc: Increment by 1.</p> <p>Dec: Decrement by 1.</p> <p>ASCII/UNICODE: Specify the character to be entered by this key.</p>
Screen Hardcopy	<p>Captures the current screen and saves it to an SD card or USB disk. For headless HMI models (cMT-SVR / cMT-SVRX) connected to specific interfaces, the available options for screen hardcopy are as follows:</p> <p>cMT-iV6: The captured screen can be saved to the SD card on cMT-iV6.</p> <p>cMT Viewer on PC: The "Screen Hardcopy" action is not supported, please use the right-click "Screenshot" function instead.</p> <p>cMT Viewer: The "Screen Hardcopy" action is not supported.</p>
Acknowledge all events (Alarms)	Acknowledges all events once.

Import Data	<p>Imports e-mail contacts or user accounts, or is used as USB Security Key login.</p> <p>Data Position: [SD card] or [USB disk].</p> <p>Account import mode: If [Overwrite] is selected, the existing accounts will be overwritten by new accounts. If [Append] is selected, accounts are appended.</p> <p>Delete file after importing user accounts: The system will delete the account data saved in the external device after importing; this can prevent the account data from leaking out.</p>
Wait Until	<p>The next group will be executed only when the condition set for a designated bit or word address is met.</p>
Data Transfer (Global)	<p>Sends the value in the designated address to another address.</p>
File Transfer	<p>Transfer files by FTP. HMI will connect to the FTP server in passive mode.</p> <p>General Tab: Download: Transfer file from FTP server to local HMI. Upload: Transfer file from local HMI to FTP server.</p> <p>Server address: [Direct]: Designate server address related settings in EBPro. [Dynamic]: Designate an address for changing the server address related settings dynamically on HMI. Suppose the dynamic address is set to LW-n, then: LW-n: Host usage (0: IP, 1 Domain name) LW-n+1: IP (4 words) LW-n+5: Port LW-n+6: Authentication (0: None, 1: Account) LW-n+7: Username (16 words) LW-n+23: Password (16 words) LW-n+39: Domain name (64 words)</p> <p>Delete the source file after successful transfer Following successful transfer, the source file will be deleted. When transferring in [Download (FTP -> HMI)] mode, please make sure that the account has the write permission on the FTP server.</p> <p>File Tab: Set file position and full path of FTP server / Local HMI. When a</p>

folder path is specified, all the files in that folder will be transferred, not including files in subfolders. When a file with identical file name already exists, it will be overwritten regardless.

Status Tab:

Designate an address for showing file transfer result and FTP server response. Please use the following link for more information on FTP server return codes.

https://en.wikipedia.org/wiki/List_of_FTP_server_return_codes

Control Token

The action to acquire or unacquire a Control Token.

Control Token: Select a Control Token.

Action: Set this action to acquire or unacquire a Control Token.

Max. waiting time: Continues or stops running the next action group if the Control Token is still not acquired even after the set [Max. waiting time].

Backup

Backup historical data or recipe data to an external storage device, or transfer data via email or FTP server.

Safely

**Remove USB
disk/SD card**

Safely remove the external storage device to ensure data integrity.



Note

- One Combo Button can only do one of these window actions, and only once: [Change Window], [Popup Window], and [Close Window].
- At most 20 groups can be created in a Combo Button, and at most 20 actions can be added into a group.
- File Transfer Error Codes:

Error Code	Description
0	File transferred successfully.
1	The HMI directory for download does not exist.
3	USB disk or SD card is not found.
4	HMI or FTP directory is empty.
5	Uploaded file does not exist.
8	Operation rejected by FTP server.
9	USB disk or SD card is full.
10	Unknown error.

13.37. Circular Trend Display

13.37.1. Overview

Circular Trend Display object draws the trend curve of Data Sampling in a polar coordinate system, where y-axis represents the radial coordinate and the x-axis represents the angular coordinate. The way to use this object is similar to using Trend Display object.

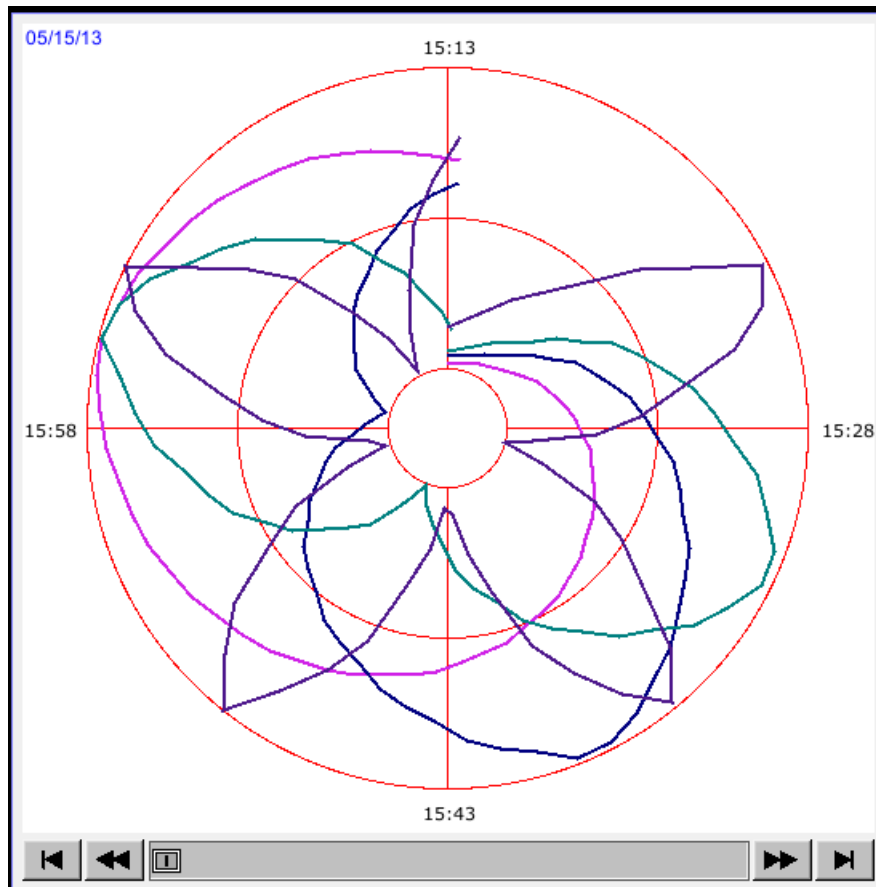

13.37.2. Configuration



Click the Circular Trend Display icon on the toolbar to open the property dialog box. Set up the properties, press OK button, and a new Circular Trend Display object will be created.

General Tab

eMT, iE, XE, mTV

cMT, cMT X

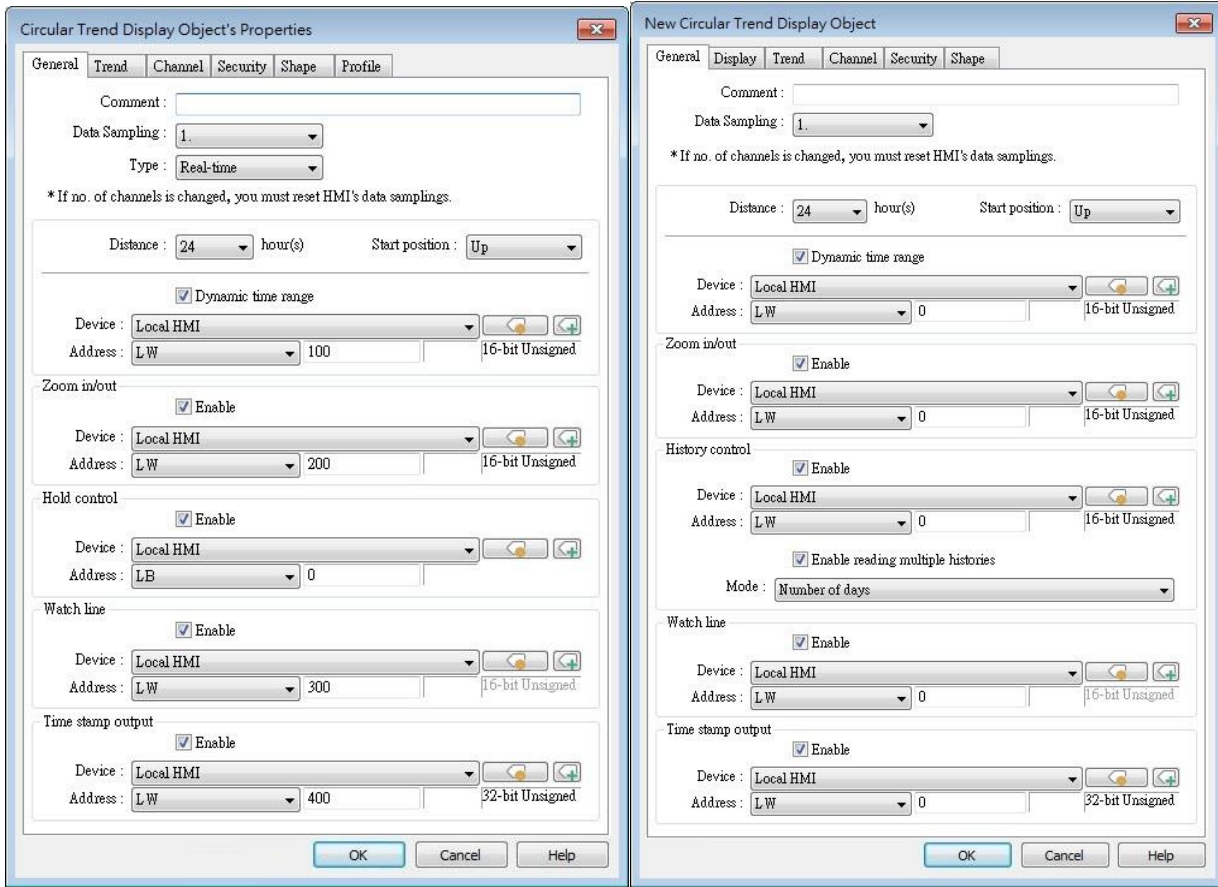

Setting	Description
Data Sampling	Selects the data source for drawing the trend curve.
Type (eMT, iE, XE, mTV Series)	Selects the type of the trend from [Real-time] or [History]. Real-time
	In this mode, it displays a fixed number of sampling data from the moment HMI starts to present. The number of sampling data is determined by the [Max. data records (real-time mode)] setting of Data Sampling object. If the number of sampling data exceeds this number, the earlier data will not be displayed. To display earlier data or the data in other days, please select [History] mode. [Hold control] address can be used to pause refreshing the display. This only stops displaying new data in the Circular Trend Display object, and the data is still being sampled by Data Sampling object.

History



In this mode, it displays the sampled data sorted by date. Select the data source from [Data Sampling], and then use [History control] address to view the records of different dates.

Note

If [Show scroll control] check box in Trend Tab is not selected, the earlier data cannot be viewed when exceeding the specified [Distance].
For example: Set [Distance] to 1 (hour.), then sampling data earlier than one hour is not displayed.

Refresh data automatically

If enabled, the window in which the Circular Trend Display object (in history mode) is placed will be refreshed once per second.

- The scroll controls can be used to check the refresh status.
If  button is displayed, the Circular Trend Display will be automatically refreshed.
If  button is displayed, the Circular Trend Display will stop being refreshed.
- Scrolling backward and viewing earlier data will disable [Refresh data automatically]. The button displayed is  at this moment.
- If [Refresh data automatically] is selected, the display is refreshed when change back to this window, regardless of the use of scroll controls.

Example: If [Refresh data automatically] is selected, scrolling to the earlier display stops auto-refresh. At this moment change to another window and then change back, the Circular Trend Display is still refreshed.

If [Refresh data automatically] is not enabled when building the project, to enable it directly on HMI, simply press . Please note that auto-refresh remains disabled after window change.

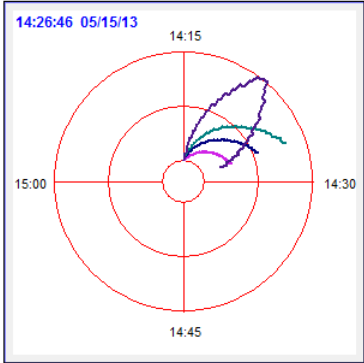
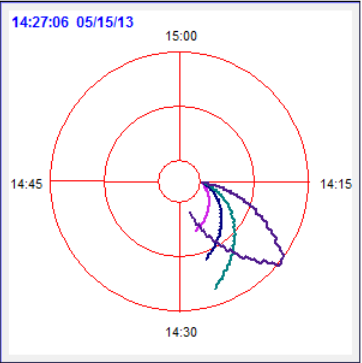
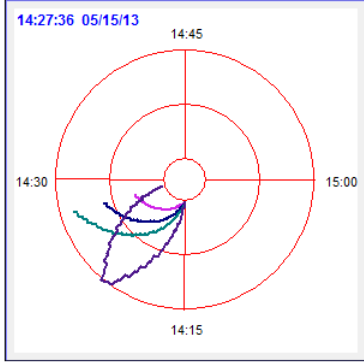
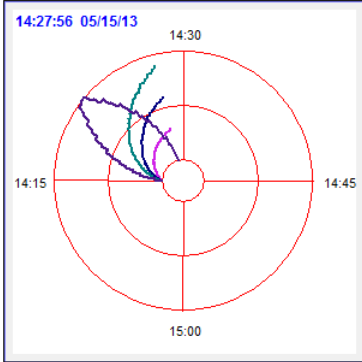
Distance	Defines the time length that the circle represents, the unit is hour, the range is 1 to 24 (hours).
Start position	The position from where to start drawing the trend curve.
(Up)	(Right)
	
(Down)	(Left)
	
Dynamic X-axis time range	If selected, a word register can be designated to control the time length of Circular Trend Display. The unit is hour. If no value is entered, the distance is set to default.
Zoom in / out	Enlarge or reduce the size of the object. The maximum size is 10 times larger. If 0 is entered in the designated register, the effect equals entering 1, the object remains the original size.
Hold control	When the register is set ON, suspend the update of Circular Trend Display. It does not stop the sampling process of Data Sampling object. This setting is available only in Real-time mode.
History control (eMT, iE, XE, mTV Series)	History data is sorted by date. The system uses [History control] to select the history data that are created in different dates and then displays it by Circular Trend Display object. If the value of the designated register in [History control] is 0, the Circular Trend Display object displays the latest

record. If the value is 1, the second latest record is displayed and so on. This setting is available only in History mode.

If use with Option List object and select data source as [Dates of historical data], the history data will be sorted by date and displayed in Option List object, see “13.29 Option List”.

In the following example, when history control address is set to LW-n, and there are 4 sampling data: 20061120.dtl, 20061123.dtl, 0061127.dtl, 20061203.dtl. The corresponding data selected by the value in history control address is as the following list.

Value in LW-n	The sampling data displayed
0	20061203.dtl
1	20061127.dtl
2	20061123.dtl
3	20061120.dtl

**History control
(cMT, cMT X
Series)**

Same as eMT, iE, XE mTV Series.

Enable reading multiple histories:

In the following two modes, days are calculated backward.

Number of days

Suppose the address is set to LW-n, then:

[LW-n]: The start day index from which to calculate number of days.

0: today, 1: yesterday, and so on.

[LW-n+2]: The total number of days before the start day.

Specific days

Suppose the address is set to LW-n, then:

[LW-n]: The start day index from which to calculate number of days.

0: today, 1: yesterday, and so on.

[LW-n+2]: The end day index, the specified value must be greater than that of the start day index. For example, if start is 4 and end is 7, the specified days will be 4 days before to 7 days before.

Watch line

Displays a watch line when user touches the Circular Trend Display object, and the sampling data at the position of the watch line is output to the designated register. To display

sampling data with multiple channels, the system consecutively writes the data of each channel to the designated word register and the following registers. If the data format of each channel is different, the channels are sorted by the data format of its corresponding register. In the following example, when watch address is set to LW-n, and there are 4 sampling data, the format of each data is: 16-bit Unsigned, 32-bit Unsigned, 32-bit Signed, and 16-bit Signed. The corresponding watch address is as the following list.

Channel	Data Format	Data Length	Watch Address
0	16-bit Unsigned	1 Word	LW-n
1	32-bit Unsigned	2 Words	LW-n+1
2	32-bit Signed	2 Words	LW-n+3
3	16-bit Signed	1 Word	LW-n+5

Time stamp output

If selected, the system will start counting time from the first data sampled, and output the elapsed time counted of the latest data sampled to the register designated in [Time stamp output + 2]. When pressing a point on the trend curve, the relative time of the nearest data sample is then output to [Time stamp output address].

Note

The format of the register designated in [Time stamp output] and [Time stamp output + 2] must be 32-bit. [Time stamp output + 2] is only available for Real-time mode while [Time stamp output] is available for Real time mode and History mode.

Display Tab

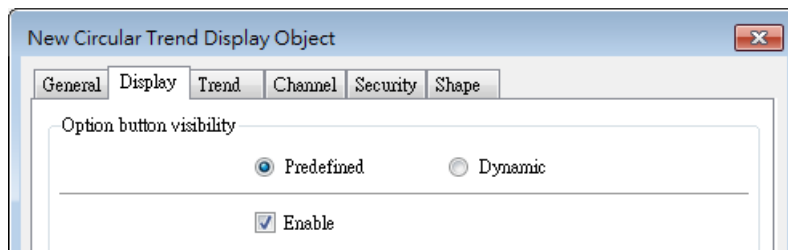

Display settings in this page are only supported on cMT / cMT X Series models.

Setting

Description

Option button visibility

Show or hide the option button .

Predefined

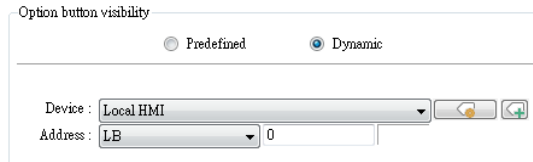

Select [Enable] to show the option button.

Dynamic



Option button visibility

Predefined Dynamic

Device : Local HMI  

Address : LB

Designate a bit address to control option button visibility.

Trend Tab

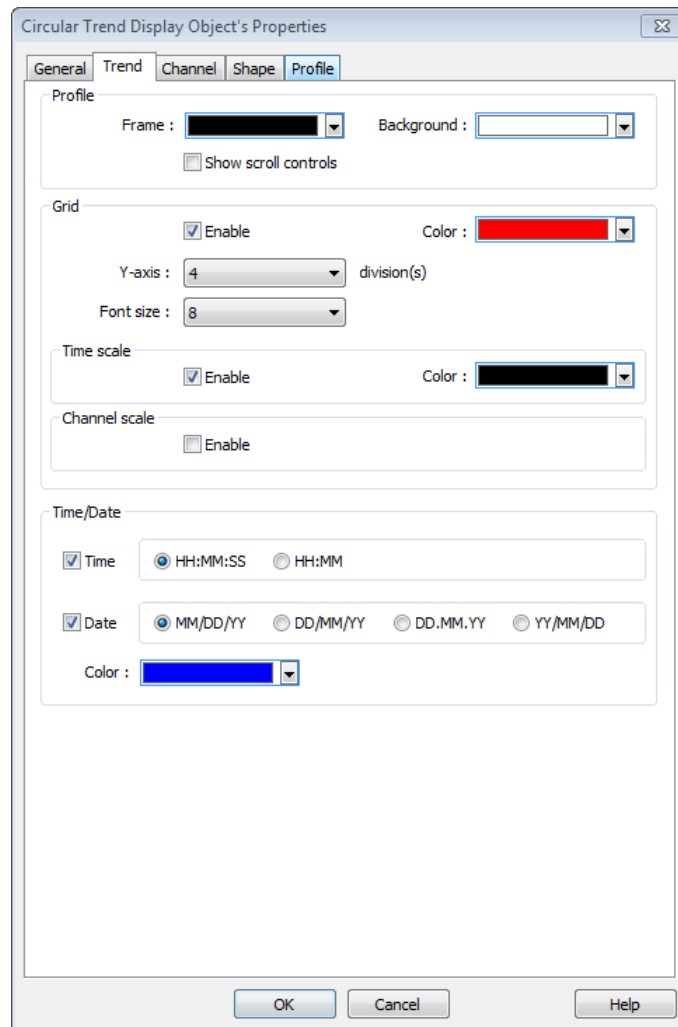

Circular Trend Display Object's Properties

General Trend Channel Shape Profile

Profile

Frame : Background :

Show scroll controls

Grid

Enable Color :

Y-axis : division(s)

Font size :

Time scale

Enable Color :

Channel scale

Enable

Time/Date

Time HH:MM:SS HH:MM

Date MM/DD/YY DD/MM/YY DD.MM.YY YY/MM/DD

Color :

OK Cancel Help

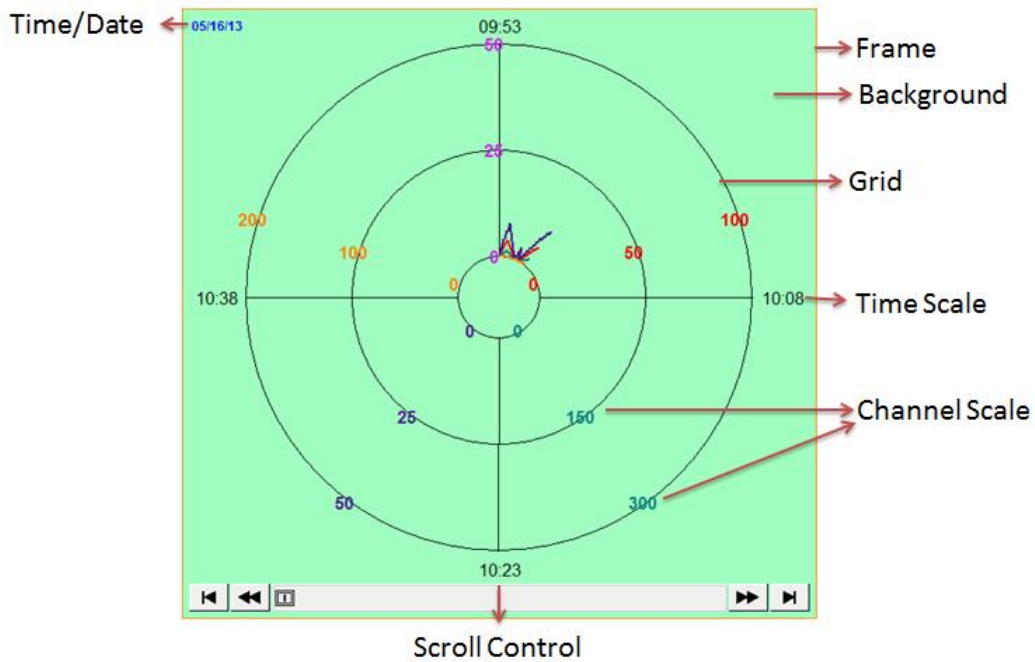

Setting	Description
Profile	<p>Frame Sets the color of the frame of the object.</p> <p>Background Sets the color of the background of the object.</p> <p>Show scroll controls The scroll controls are displayed for scrolling to view the sampling data of other time range. The minimum scrolling unit is determined by the setting of [Distance] in General tab. If [Show scroll controls] check box is not selected, the earlier data cannot be viewed when exceeding the specified [Distance]. For example: Set [Distance] to 1 (hour.), then sampling data earlier than one hour is not displayed.</p>
Grid	<p>Sets the number and the color of the dividing lines.</p> <p>Y-axis Sets the number of divisions on Y axis.</p> <p>Font size Sets the size of the font which labels the time scale or channel scale.</p> <p>Time scale If enabled, displays the time scale. When the time length is longer than 1 hour, the scale division is 1 hour. When the time length is set to 1 hour, the scale</p>

division is 15 minutes.

Channel scale

If enabled, displays the channel scale. The color of the font which labels the channel scale corresponds to the setting of the trend curve of each channel.

Time / Date

Time

Sets the display format of time.

Date

Sets the display format of date.

Channel Tab

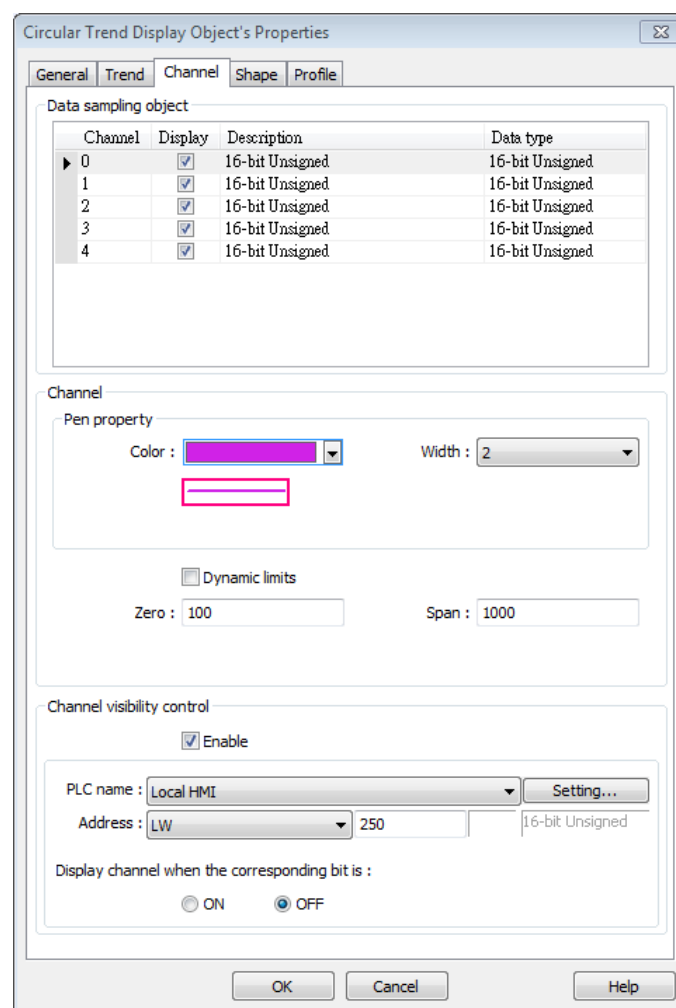

Setting

Channel

Description

Sets the style and the color of the trend curve, and the upper and lower limit of data that can be drawn on the trend curve. Up to 8 channels are supported simultaneously.

Not selecting [Dynamic limits]

The upper and lower limits of the data are set by constants.

Selecting [Dynamic limits]

The upper and lower limits are set by the designated register. When the address is LW-n, the corresponding addresses are as the following list.

Data format	16-bit	32-bit
Lower limit	LW-n	LW-n
Upper limit	LW-n+1	LW-n+2

Channel Visibility Control

If [Enable] is selected, the bits of the designated word register will be used to show/hide each channel. First bit (Bit-0) controls the first channel; second bit (Bit-1) controls the second channel, and so on.

Display channel when the corresponding bit is:

If [ON] is selected, when the corresponding bit is OFF, the channel is hidden. If [OFF] is selected, when the corresponding bit is ON, the channel is hidden.

In the following example, the control address of channel visibility is set to LW-0 and each channel shows when the corresponding bit is OFF. If there are 5 channels, the visibility of the channels is as the following list.

Channel	Control address	Bit state	Display
0	LW_bit-000	OFF	YES
1	LW_bit-001	ON	NO
2	LW_bit-002	ON	NO
3	LW_bit-003	OFF	YES
4	LW_bit-004	OFF	YES

13.38. Picture View

13.38.1. Overview

Picture View object plays slideshow of picture files saved in an external device such as a USB drive or SD card.

This object does not work remotely on cMT Viewer.

13.38.2. Configuration

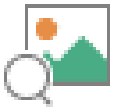

Click the Picture View icon on the toolbar to open the property dialog box. Set up the properties, press OK button, and a new Picture View object will be created.

General Tab

New Picture View Object

General Outline Security

Comment : _____

File position

USB disk 1 USB disk 2 SD card

Directory

Dynamic folder path

Device : Local HMI

Address : LW 0 20 word(s)

File selection

Automatically display the newly generated image

Send notification when switching to a new picture

Set ON Set OFF

Device : Local HMI

Address : LB 0

Specify file from address

Disable left/right swiping and hide file browser/first/last buttons

Device : Local HMI

Address : LW 0 20 word(s)

* Filenames must contain only ASCII characters. Unicode is not supported.

OK Cancel Help

Setting	Description
File position	Select the file source of the picture files from [SD card] or [USB disk].
Directory	Specify the directory where the picture files are saved. The directory can be the one used for Video Input's capture feature or Function Key's screen hardcopy feature. The picture file saved in the external device can be immediately displayed. Dynamic folder path Designate folder path by a local address.
File selection	Automatically display the newly generated image When a new image is generated in the designated folder path, Picture View object will automatically display the new image. Send notification when switching to a new picture When [Automatically display the newly generated image] is selected, the state of the designated address changes to On/Off when the new picture is displayed on HMI. Specify file from address (hide toolbar) When enabled, the displayed picture is designated by a file name in a local address, and the toolbar will be hidden.



Note

- The file name must be all in ASCII characters, and the Unicode characters are not supported.
- The supported picture formats are: .jpg, .bmp, .gif, .png.
- The size of the picture that can be displayed on an iP/iE/eMT/XE/mTV model is calculated in the following formula:

$$(\text{image.width} \times \text{image.height}) < (\text{screen.width} \times \text{screen.height}) \times 4$$
 Pictures with sizes exceeding this range cannot be displayed on HMI.
- Two-finger zoom in / out gestures are supported on capacitive touchscreens.

Outline Tab

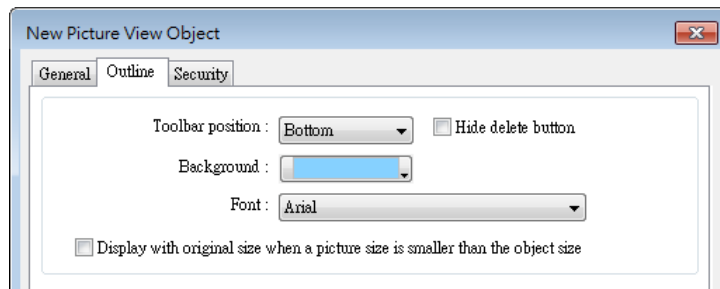

Setting	Description
Outline	Specify the position, background color, and font of Picture View object. (Supported only on iP/iE/eMT/XE/mTV models.)
Hide delete button	When selected, the delete button for deleting the viewed picture will be hidden in the Picture view object.
Display with original size when a picture size is smaller than the object size.	When selected, the picture will be displayed in its original size if it is smaller than the Picture View object. This can avoid distortion caused by enlarging the picture.

13.39. File Browser

13.39.1. Overview

File Browser object can display filenames and their directories saved in the SD card or USB disk. Apart from browsing for the files in the external devices, the filenames and the directories selected in File Browser object can be written to the designated address. This object does not work remotely on cMT Viewer.

13.39.2. Configuration



Click the File Browser icon on the toolbar, or select [Object] » [File Browser] to open a File Browser object property dialog box and set up the properties.

General Tab

New File Browser Object

General Outline Security Shape

Folder path address

Enable

Device : Local HMI Settings...

Address : LW 0 20 word(s)

File name address

Enable

Device : Local HMI Settings...

Address : LW 0 20 word(s)

Full (folder + file name) address

Enable

Device : Local HMI Settings...

Address : LW 0 20 word(s)

Control address

Enable

Device : Local HMI Settings...

Address : LW 0 22 word(s)

Command : LW-0
0 : none, 1 : delete, 2 : rename

Result : LW-1
0 : success, 1 or more : error

New file name : LW-2

OK Cancel Help

Setting	Description
Folder path address	Current directory.
File name address	The file name of the currently selected file.
Full (folder + file name) address	The full directory and file name of the currently selected file.
Control address	<p>Designate the control address used for deleting a file or changing file name in File Browser.</p> <p>Command: Control Address</p> <p>0: None 1: Delete 2: Rename 3: Select (only supported on cMT / cMT X Series models)</p> <p>Result: Control Address+1</p> <p>0: Success 1 or more: Error</p> <p>New File Name: Control Address +2</p>

Outline Tab

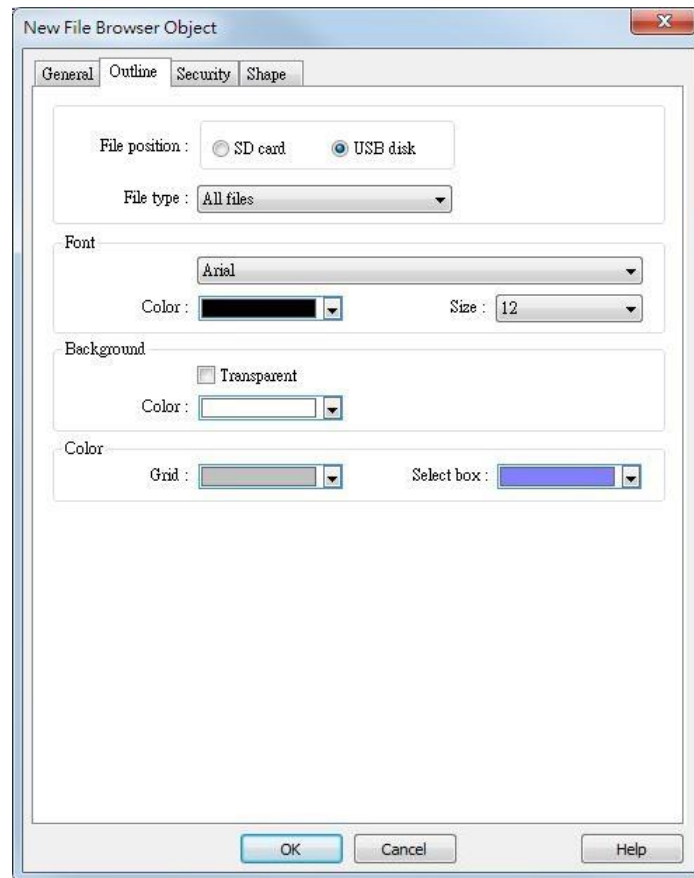

Setting	Description
Folder position	Select the position of the file from SD card or USB disk.
File type	File types to be displayed. Options include all files, CSV files, or image files. For cMT / cMT X Series models, there is also a PDF file option for use in conjunction with PDF reader.
Font / Background / Color	Set the attributes and font of the object.

 **Note**

- The file name and the directory of the selected file will be written to the designated address. To change file selection in File Browser to another file by changing the address, please enter the position of the file and then use the select command (=3).
- The system will read the folder path address and file name address when the HMI is restarted or when an external device is inserted to the unit. If valid data is can be read

from the designated address, the system will then automatically navigate to the appropriate directory and highlight the file according to the data read. If [Folder path address] is not enabled, the data at Full (folder + file name) address will be read.

13.40. Import/Export

13.40.1. Overview

With Import/Export object, Recipe Database or String Table can be imported or exported.

13.40.2. Configuration



Click the Import/Export icon on the toolbar to open the Import/Export Object management dialog box. To add an Import/Export object, click [New], set up the properties, press OK button and a new Import/Export object will be created.

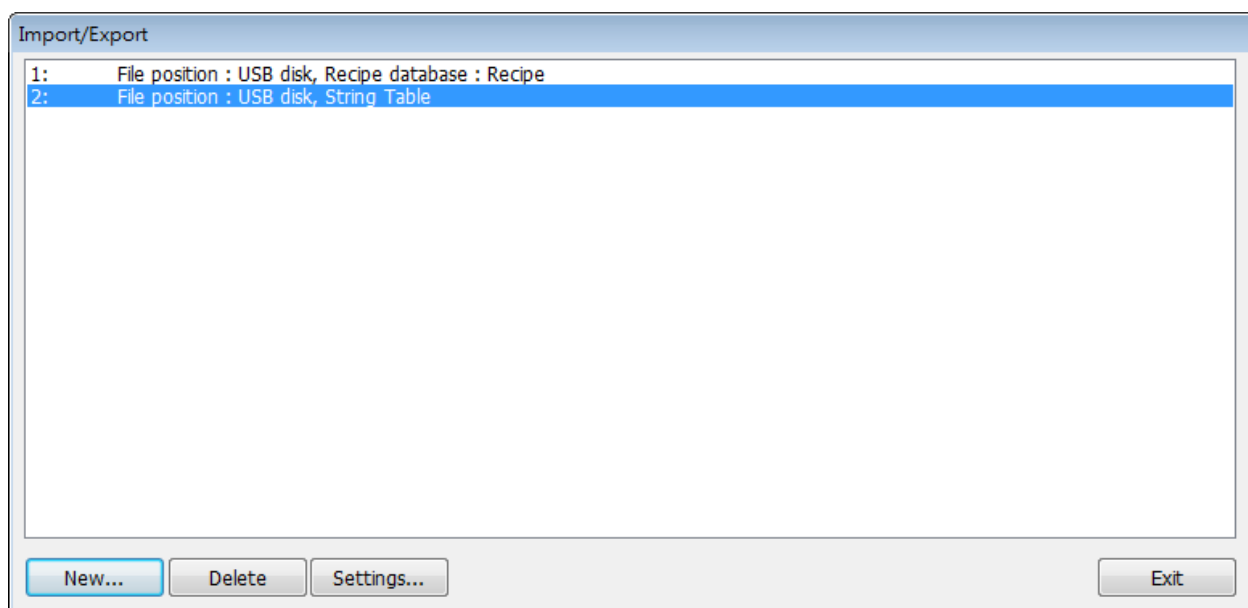

General Tab

Setting	Description
Type	Select the file source from Recipe Database or String Table.
File position	Select the position of the file to be imported / exported from SD card, USB disk, or Remote HMI (cMT / cMT X Series). When Remote HMI is selected, please note that only files in cMT / cMT X Series models can be imported.
Recipe	Select the recipe. This option is hidden when select String Table.
Control address	Designate the control address used for performing import/export, or displaying the result. Control: Control Address Recipe Database: 0: None 1: Import 2: Export (no overwrite)

	3: Export String Table: 0: None 1: Delete 2: Import 4: Export (no overwrite) 5: Export Status: Control Address+1 0: Idle 1: Busy Result: Control Address +2 1: Success 4: The file already exists, no overwriting. Other: Error
File name address	The name of the imported/exported file. If [Include folder path] is selected, the full directory and file name will be included at this address.
Folder path address	The directory of the imported/exported file.
Remote HMI address	When the file position is [Remote HMI (cMT / cMT X Series)], please enter the remote HMI's IP address in this field.

Example 1

The following is an example on recipe export/import settings.

Field	Setting
File position	USB disk
Recipe	Recipe_A (or other recipe)
Control address	LW-100
File name address	LW-200
Folder path address	LW-250

1. Create two ASCII Input objects. Set address to LW-200 and LW-250 respectively.
2. Enter the file name in LW-200: 2015_recipe.csv.
3. Enter the folder path in LW-250: Setting.
4. Use a Set Word object to write value 3 to LW-100. Then, Recipe_A will be exported to the USB disk, in the "Setting/2015_recipe.csv" file.

 **Note**

- When performing “Export (no overwrite)” command, if the target file already exists, the export operation will be canceled, and the result value will be set to “4”.

The following lists the result values and the information.

Result (HEX)	Information
0x1	Success.
0x4	File already existed and will not overwrite.
0x10	Invalid command.
0x100	Data contains non-numeric data.
0x101	Path contains invalid string “..”.
0x102	Communication error while updating Recipe DB.
0x103	Error while reading Recipe DB information from project file.
0x200	General exception.
0x201	General status error.
0x202	Import to unknown database type.
0x203	Error while validating Recipe DB table definition.
0x204	Error while validating Recipe DB table data.
0x205	Error while writing Recipe DB table definition.
0x206	Error while writing Recipe DB table data.
0x300	File error: Unknown error.
0x301	File error: Empty file name.
0x302	File error: The external device does not exist.
0x303	File error: Invalid file name (directory or special files), or a folder with the same name already exists.
0x304	File error: Unable to remove file.
0x305	File error: Open file stream error.
0x306	File error: Unhandled BOM.
0x307	File error: Error while parsing CSV file (incorrect formats).
0x308	File error: Insufficient space on the external device.
0x309	File error: Unable to find the file.
0x30A	File error: The CSV file contains over 10000 data rows.
0x400	Database general exception.

0x401	Database error: Unable to open table.
0x402	Database error: Unable to get rows.
0x403	Number of columns in CSV file and in Recipe DB do not match.
0x501	Unable to connect remote HMI.
0x503	Import from remote HMI database is prohibited.
0x504	Import from remote HMI database is not supported.

13.41. Pie Chart

13.41.1. Overview

The Pie Chart is divided into slices to illustrate numerical proportion according to the value of the designated read address.

13.41.2. Configuration



Click the Pie Chart icon on the toolbar, set up the properties, and press OK to create the object.

General Tab

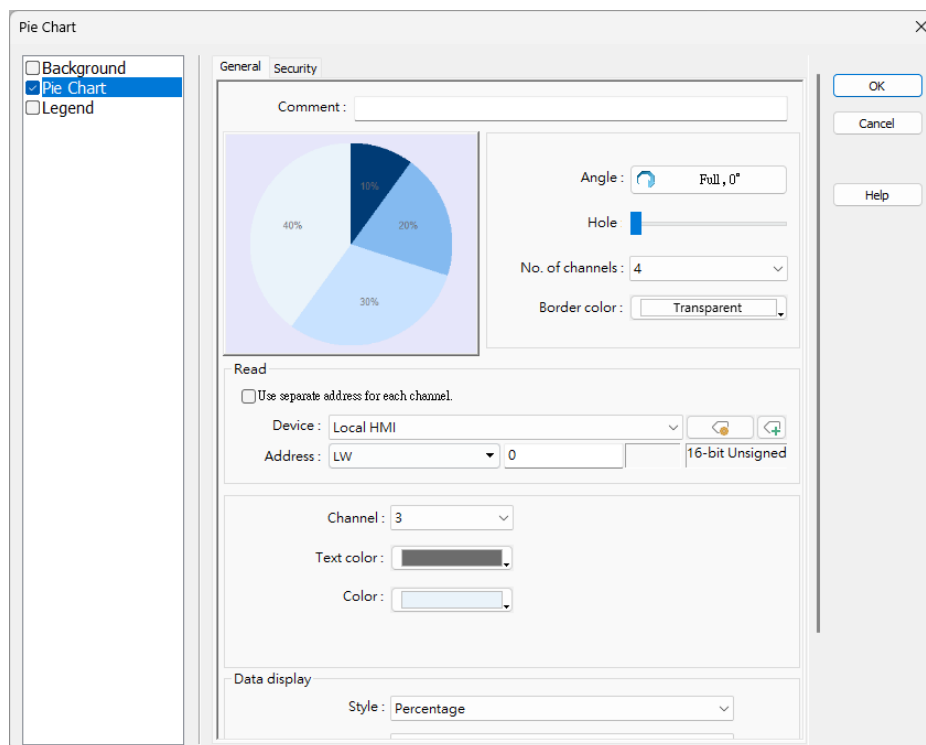

Setting	Description
Angle	<p>Predefine</p> <p>Pick from the thumbnails configure directions and angle ranges with ease.</p> <p>Custom</p> <p>Configure the direction and angle. If [Full circle] isn't selected, then [End degree] must be set.</p>

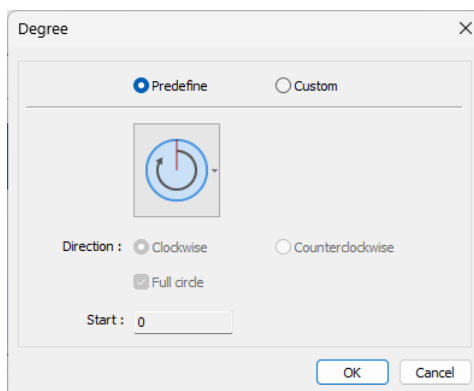
**Hole**

Set the size of the hollow circle in the center of Pie Chart.

**No. of channels**

Set the number of channels to be displayed. The range is from 2 to 16.

Border color

Set the color of the border.

Read address

The address is for channel 1. The following consecutive addresses are for the rest of the channels. For example, if the Read Address is LW-0, then the Read Address for channel 2 is LW-1; channel 3 is LW-2...and so on.

Use separate address for each channel

When enabled, the read address for each channel can be set.

Channel

Set the [Text color], [Background color], [Pattern color], and [Pattern style] of the selected channel. The [Background color] is for the [Pattern style] that has background.

Data display

The [Style] can be set as [None], [Value] and [Percentage]. The [Font] and [Size] are for the text on the chart. For Value Style, the [Right of decimal Pt.] can set the value on the chart to be displayed with the decimal point.

13.41.3. Combo Setting

cMT / cMT X Series HMI support combo setting for Pic Chart, which allows setting of multiple related objects at a time. Pic chart can be set with Background and Legend.

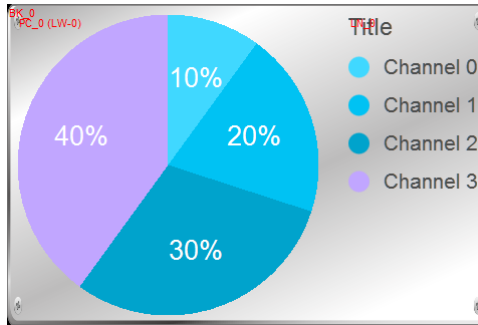

Background

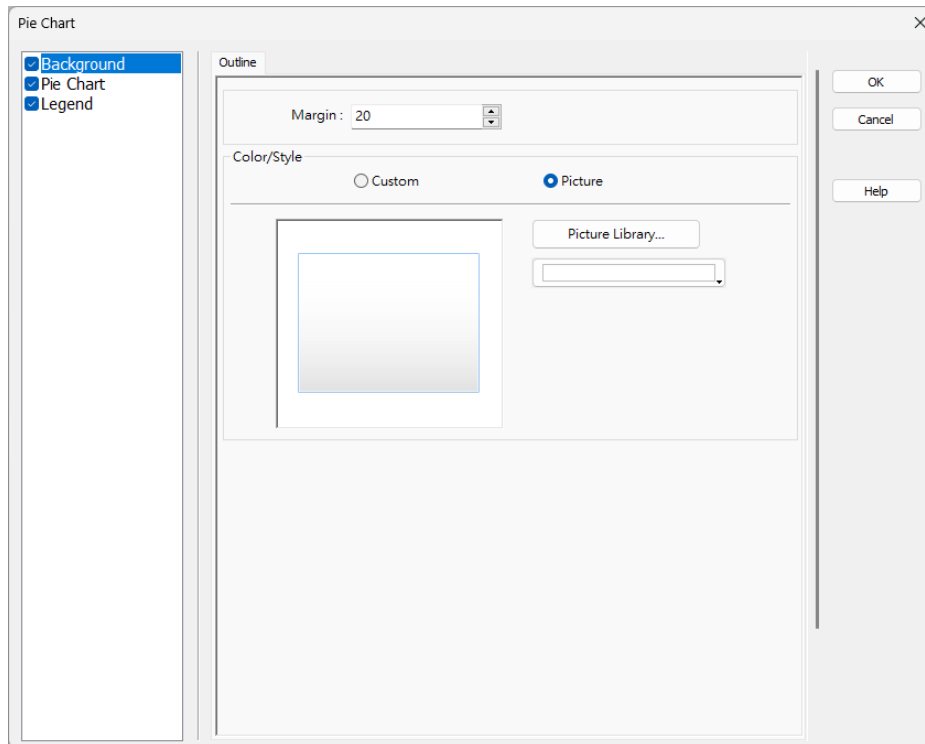

Setting	Description
Margin	Specify the space between the background edge and the objects.
Color/Style	<p>Customize</p>

Select a suitable background pattern and color.

Picture



Use the default picture or choose a picture from Picture Library.

Legend

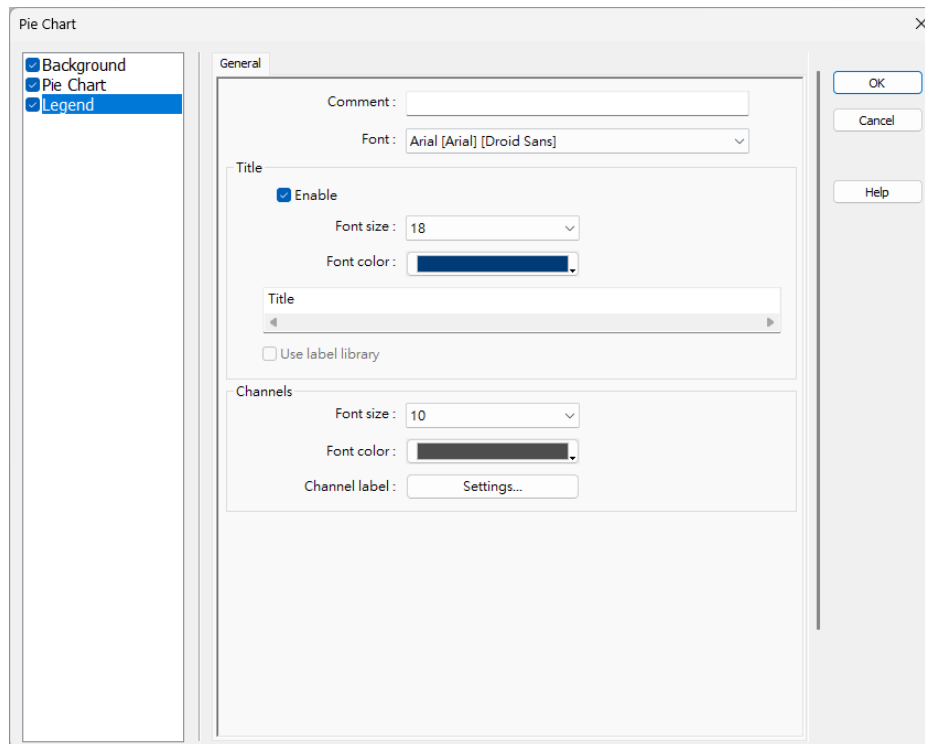

Setting

Description

Title

Set whether to use a title for Pic Chart, and set the font size / font color of the title. The title can be selected from Label Library.

Channel

Set the channel label. When using Label Library, the number of the channels should be the same as the number of states in the library.

13.42. Barcode

13.42.1. 1D Barcode Display

13.42.1.1. Overview

The 1D Barcode Display object generates a corresponding barcode in the window using the data entered into the specified word address, intended for scanning purposes.

13.42.1.2. Configuration



Click the 1D Barcode Display icon on the toolbar to open the property dialog box. Set up the properties, press OK button, and a new 1D Barcode Display object will be created.

General Tab

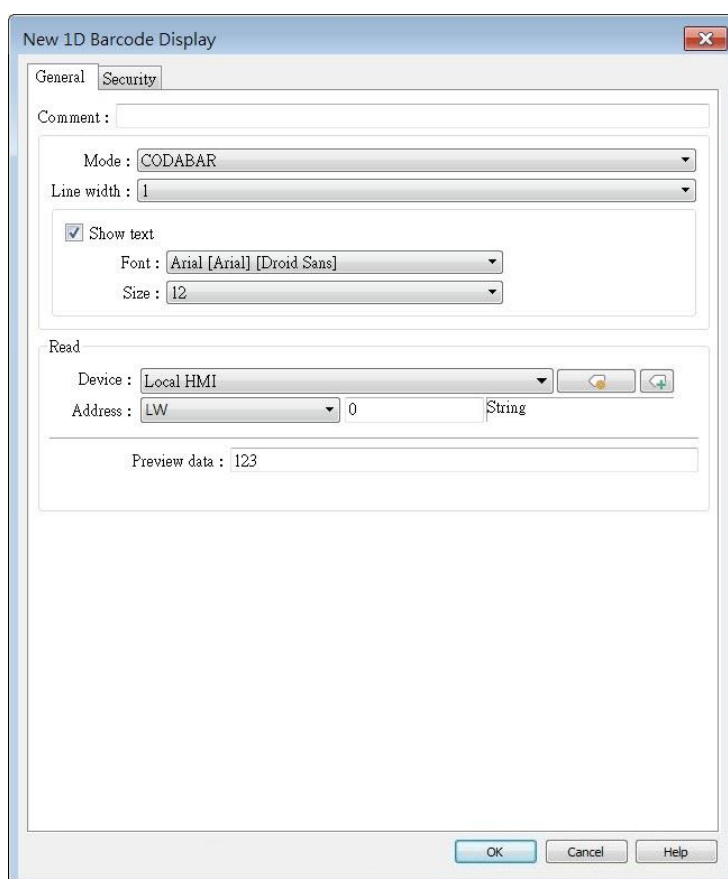

Setting	Description
Mode	Supports CODABAR, CODE 39, CODE 93, CODE 128, EAN 8, EAN 13.

Line width	Set the line width of the 1D barcode.
Show text	Set whether to display corresponding text below the 1D barcode. Font Set the font for the displayed text. Size Set the font size for the displayed text.
Read address	The 1D Barcode Display object will display the barcode generated from the data entered into the specified word address. The word length limit: 1 ~ 80.
Preview data	This data preview will be converted into a barcode, aiding in the design and preview of the project screen.

13.42.2. 2D Barcode Display

13.42.2.1. Overview

The 2D Barcode Display object transfers the information from the read address into QR Code or Aztec Code.

13.42.2.2. Configuration



Click the 2D Barcode Display icon on the toolbar to open the property dialog box. Set up the properties, press OK button, and a new 2D Barcode Display object will be created.

General Tab

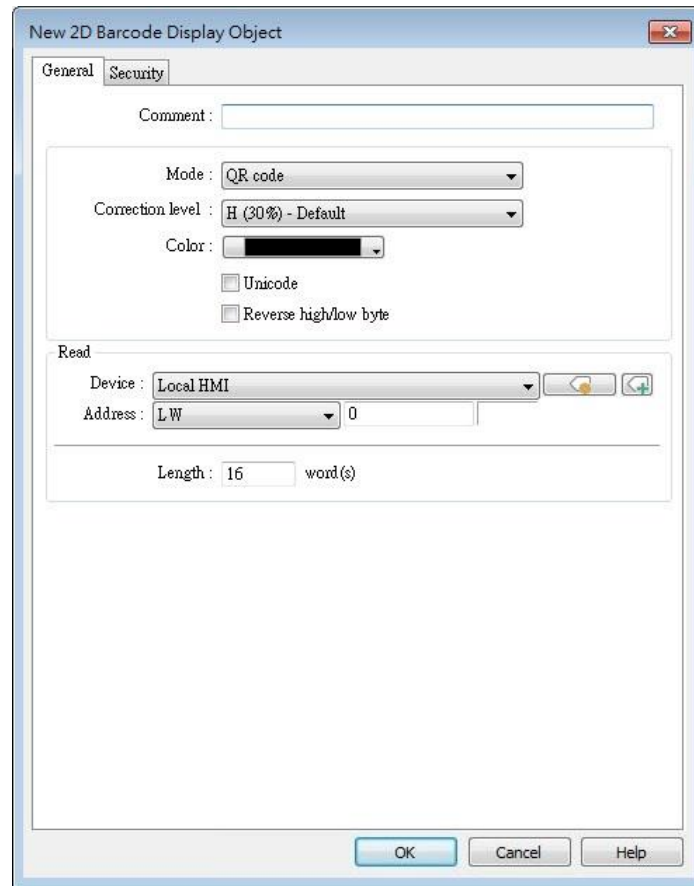

Setting	Description										
Mode	Supports QR code, Aztec code, Data Matrix.										
Correction level	<p>2D barcodes have error correction capability to restore data if the barcode is dirty or damaged.</p> <p>QR code</p> <p>Four correction levels are available: L, M, Q, and H. The data restoration rate is listed below. (The data restoration rate for total codewords. Codeword is a unit that constructs the data area.)</p> <table border="1"> <thead> <tr> <th colspan="2">Correction Level</th> </tr> </thead> <tbody> <tr> <td>L</td> <td>7%</td> </tr> <tr> <td>M</td> <td>15%</td> </tr> <tr> <td>Q</td> <td>25%</td> </tr> <tr> <td>H</td> <td>30%</td> </tr> </tbody> </table> <p>Aztec code</p> <p>Aztec code supports error correction levels from 5% to 95%. Specifying a higher correction value results in a larger printed symbol and increases accuracy.</p>	Correction Level		L	7%	M	15%	Q	25%	H	30%
Correction Level											
L	7%										
M	15%										
Q	25%										
H	30%										
Color	Set the 2D barcode color.										
UNICODE	<p>By default, the 2D barcode is generated via ASCII encoding. If this check box is selected, the 2D barcode is generated via UNICODE encoding.</p> <p>For characters that are not ASCII defined English alphabets or</p>										

	numbers, for example, Chinese or Korean characters, please select the Unicode check box.
Reverse high/low byte	By default, the 2D barcode is displayed in high byte then low byte order. With this option selected, the 2D barcode is displayed in a reverse order, low byte then high byte.
Read address	The 2D Barcode Display object will display the 2D barcode generated from the information entered by the read address. The word length limit of QR code: 1 ~ 1024. The word length limit of Aztec code and Data Matrix: 1 ~ 2048.

13.42.3. Push Notification Barcode Display

13.42.3.1. Overview

Push Notification Barcode Display object displays the QR code needed for setting up EasyAccess 2.0 push notification via messaging applications.

13.42.3.2. Configuration



Click the [Object] » [Barcodes] » [Push Notification Barcode Display] to open the property dialog box. Set up the properties, press OK button, and a new Push Notification Barcode Display object will be created.

General Tab

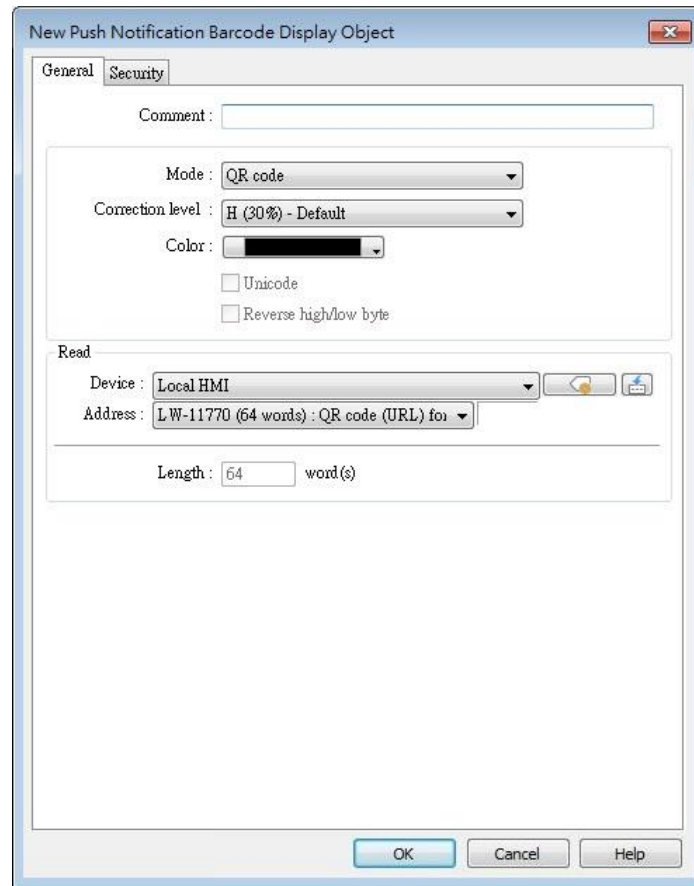

Setting	Description										
Mode	Supports QR code, Aztec code, Data Matrix.										
Correction level	<p>2D barcodes have error correction capability to restore data if the barcode is dirty or damaged.</p> <p>QR code</p> <p>Four correction levels are available: L, M, Q, and H. The data restoration rate is listed below. (The data restoration rate for total codewords. Codeword is a unit that constructs the data area.)</p> <table border="1"> <thead> <tr> <th colspan="2">Correction Level</th> </tr> </thead> <tbody> <tr> <td>L</td> <td>7%</td> </tr> <tr> <td>M</td> <td>15%</td> </tr> <tr> <td>Q</td> <td>25%</td> </tr> <tr> <td>H</td> <td>30%</td> </tr> </tbody> </table> <p>Aztec code</p> <p>Aztec code supports error correction levels from 5% to 95%. Specifying a higher correction value results in a larger printed symbol and increases accuracy.</p>	Correction Level		L	7%	M	15%	Q	25%	H	30%
Correction Level											
L	7%										
M	15%										
Q	25%										
H	30%										
Color	Set the 2D barcode color.										
UNICODE	Cannot be changed by default.										
Reverse high/low byte	Cannot be changed by default.										

Read address Cannot be changed by default.

System Parameter Settings

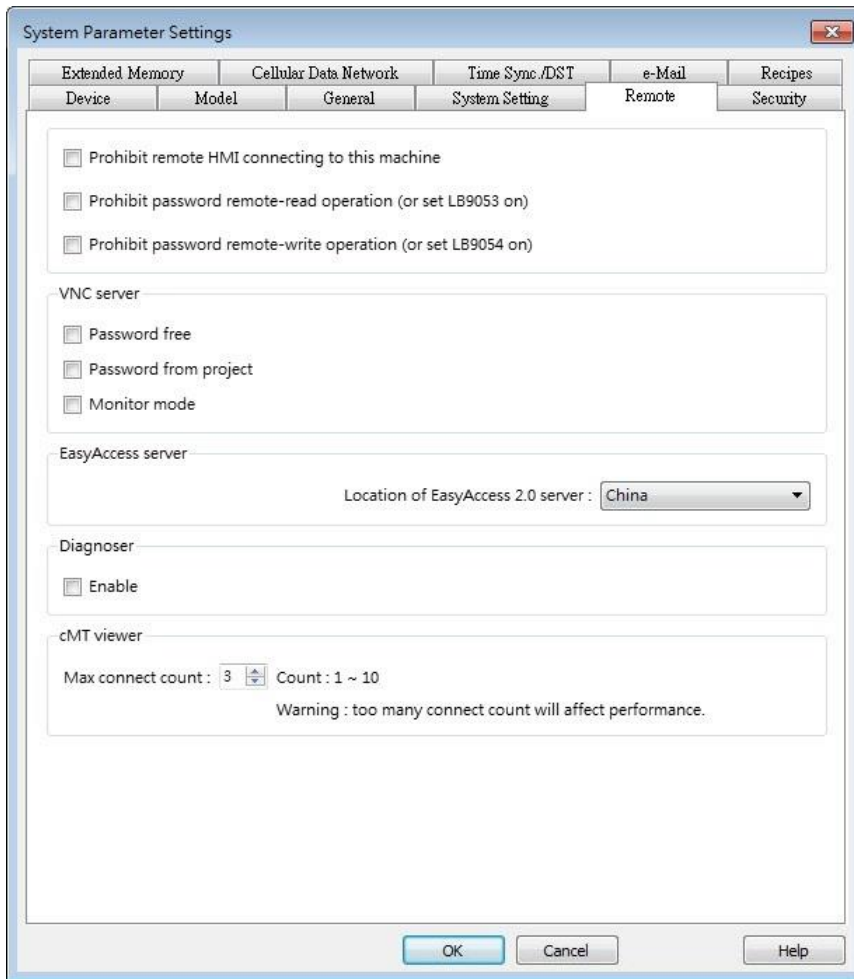

Setting	Description
EasyAccess Server	Global: Supports push notification features of WeChat, Facebook, and Line. China: Supports push notification features of WeChat only.

Push Notification Settings

After downloading the project file to HMI, the QR code will be shown on HMI screen. For more information on setting up push notifications in WeChat, Facebook, and LINE, please refer to the link below (see version 2.8 and later).

<https://support.ihmi.net/ea20/release-notes>

13.42.4. Barcode Scanner (Android Camera)

13.42.4.1. Overview

By connecting an Android device (smartphone/tablet) equipped with a camera to a cMT / cMT X HMI using cMT Viewer installed on the Android device, the camera can be used to scan 1D or 2D barcodes.

13.42.4.2. Configuration



Click the Barcode Scanner icon on the toolbar or click [Objects] » [Barcodes] and then select [Barcode Scanner]. Configure the parameters and click OK; a Barcode Scanner object will be created.

General Tab

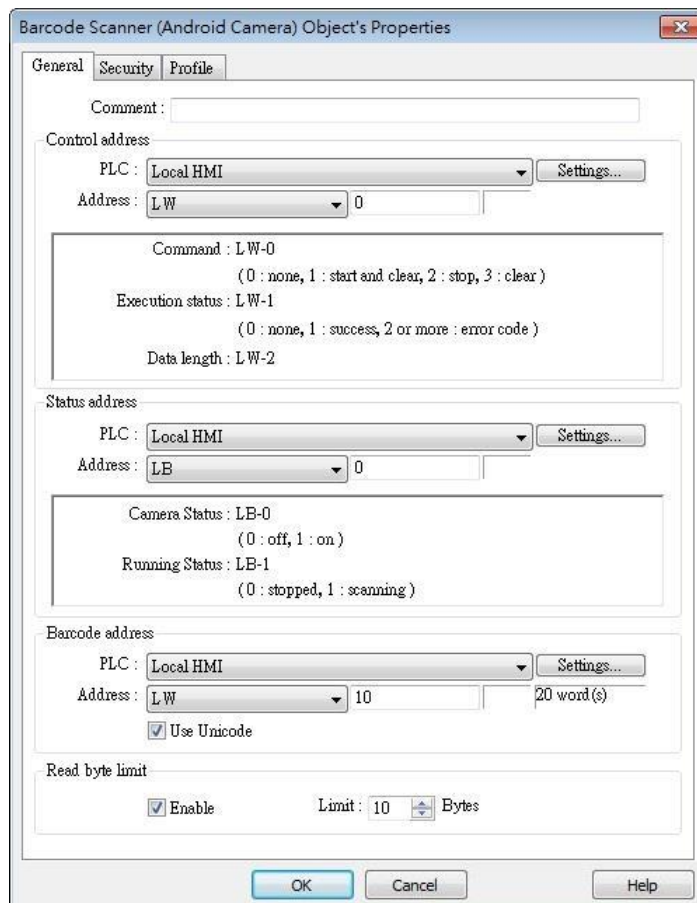

Setting	Description
Control address	Control address: Gives Command to Barcode

	Scanner. 0: None 1: Start and Clear 2: Stop 3: Clear Control address + 1: Shows Execution Status. 0: None 1: Success 2 or more: Error Code Control address + 2: Shows data length scanned.
Status address	Status address: Shows camera status is On / Off. 0: Off 1: On Status address + 1: Shows whether scanning is ready. 0: Stopped 1: Ready for scanning
Barcode address	The address that stores the data read, UNICODE is allowed.
Read byte limit	If the data read exceeds this setting, the execution status turns to 2 (error code).

Security Tab

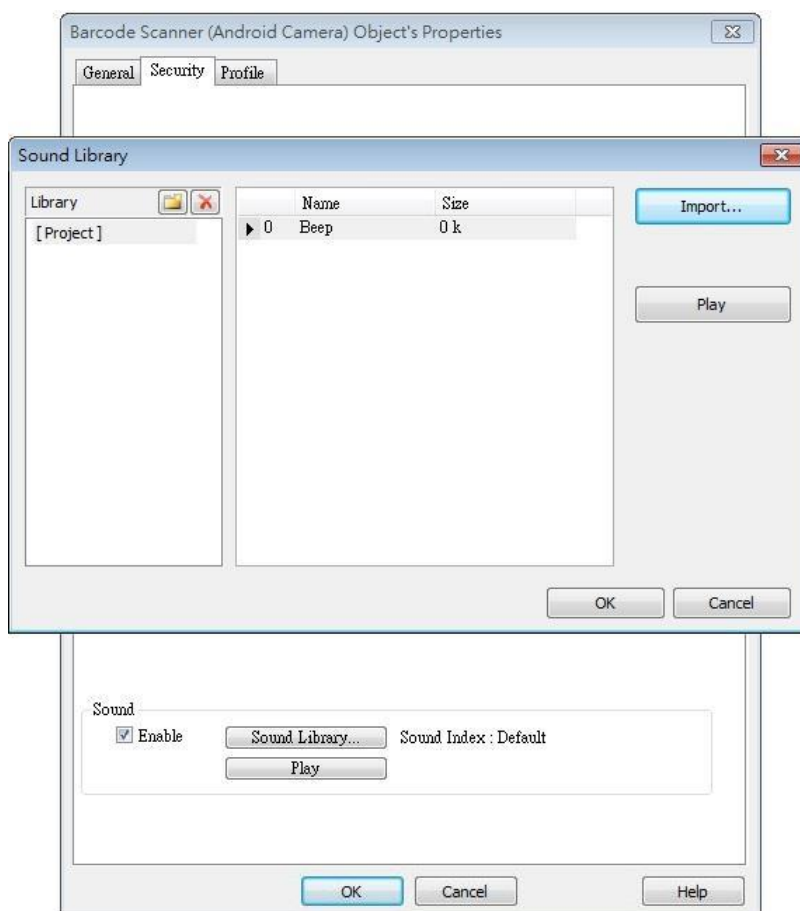

Setting	Description
Sound	If Enable is selected, when data is read, a sound is emitted. The supported sound file format is .wav.

 Note

- Barcode Scanner is currently supported on cMT-SVR and cMT3151 models. Barcode Scanner cannot be opened using simulation mode or cMT Viewer.
- Supports: EAN/UPC, Code 128, Code 39, Interleaved 2 of 5 and QR Code.
- On the device, if other applications are also using the camera, or the camera is locked, cMT Viewer may not operate properly.
- In the project, when multiple cMT Viewer devices are connected, since the same address is shared between the devices, the devices will simultaneously scan if they are displaying the same window with Barcode Scanner.

Example 1

The following demo project shows how to scan QR code using a tablet.

1. At the beginning, the display is dark.

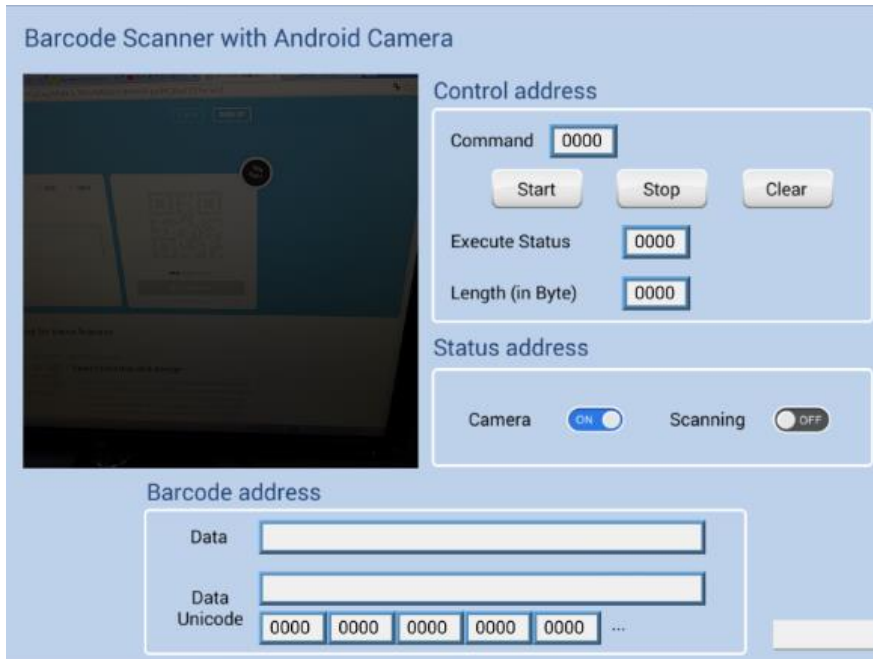

2. Tap Start button, the status of Scanning turns ON, the display turns bright, and is ready for scanning.

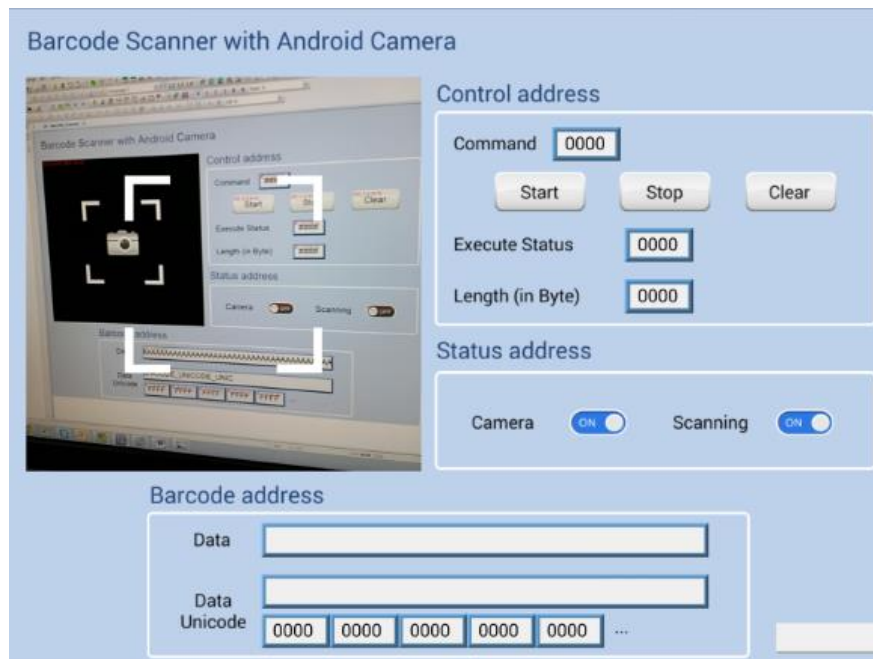

3. When a QR code is read, the Execute Status turns 1, and the QR code is captured, its content will be displayed in Barcode Address group box. Unicode is also supported.

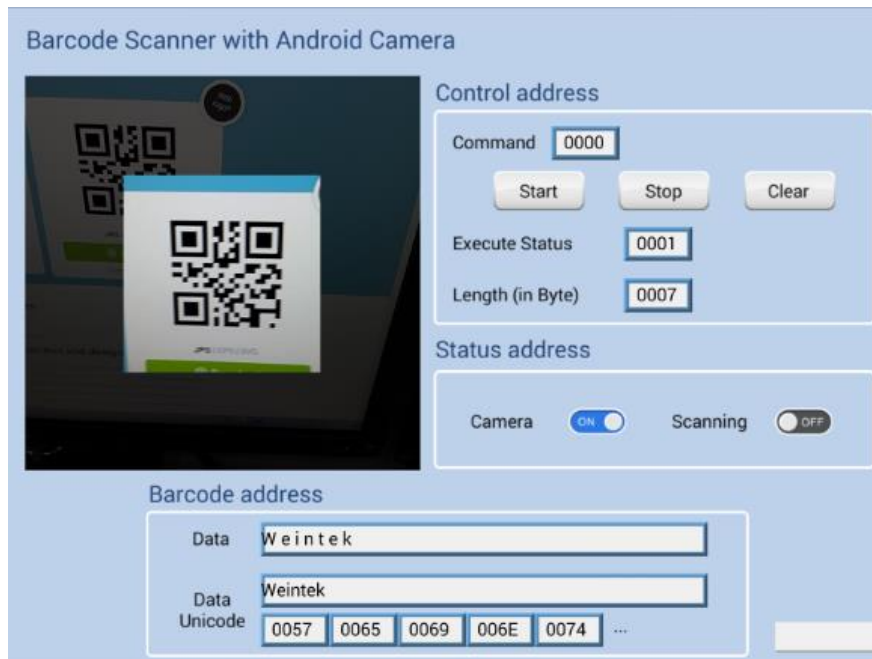

4. If the size of the data read exceeds the maximum allowable size set in Read Byte Limit (10 bytes in this project), the Execution Status turns to 2 (error code). The exceeding part will still be displayed in the ASCII objects in Barcode Address group box, since the data length displayed depends on the ASCII object settings (20 words in this project).

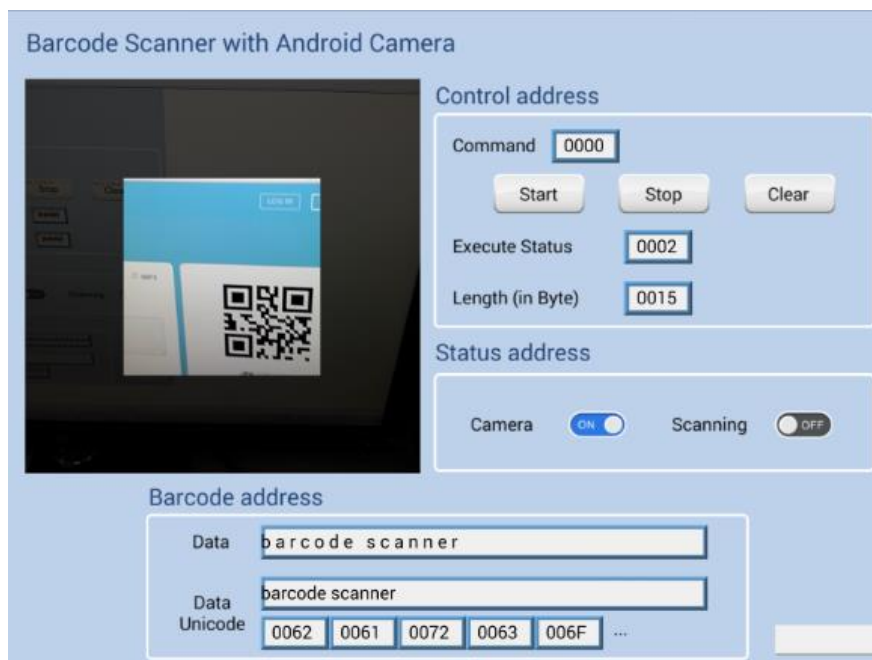

5. After changing to another page, Scanning turns OFF, the parameters are reserved. The parameters will be cleared when next time Start button is tapped, or Clear button is tapped.

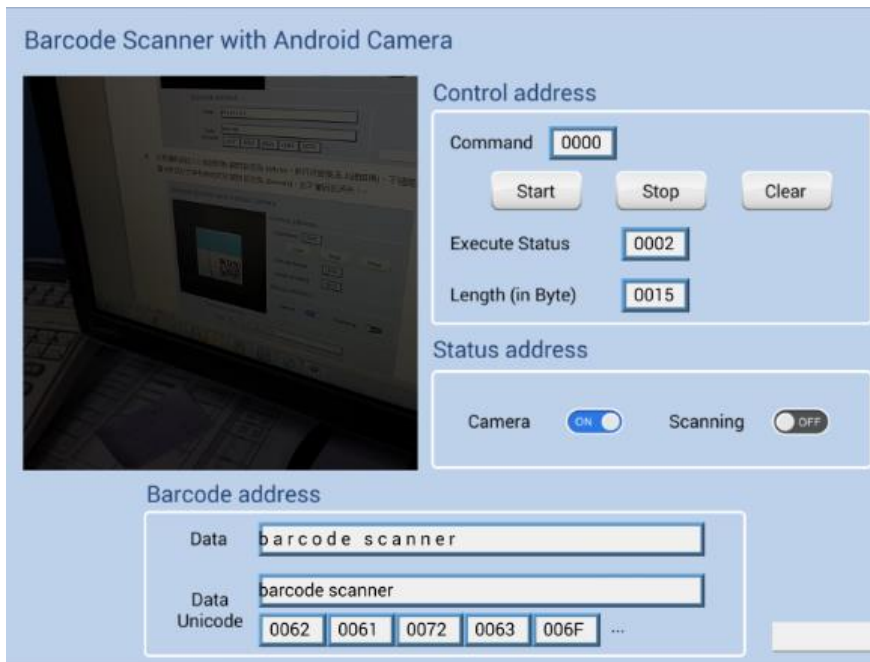

13.43. String Table

13.43.1. Overview

By pre-configuring the texts and their corresponding numbers in the String Table, the text can be changed dynamically on HMI. String Table can also be used in a multi-language environment.

13.43.2. Configuration



Click [Project] » [String] to open the property dialog box. Set up the properties, press OK button, and a new String Table object will be created.

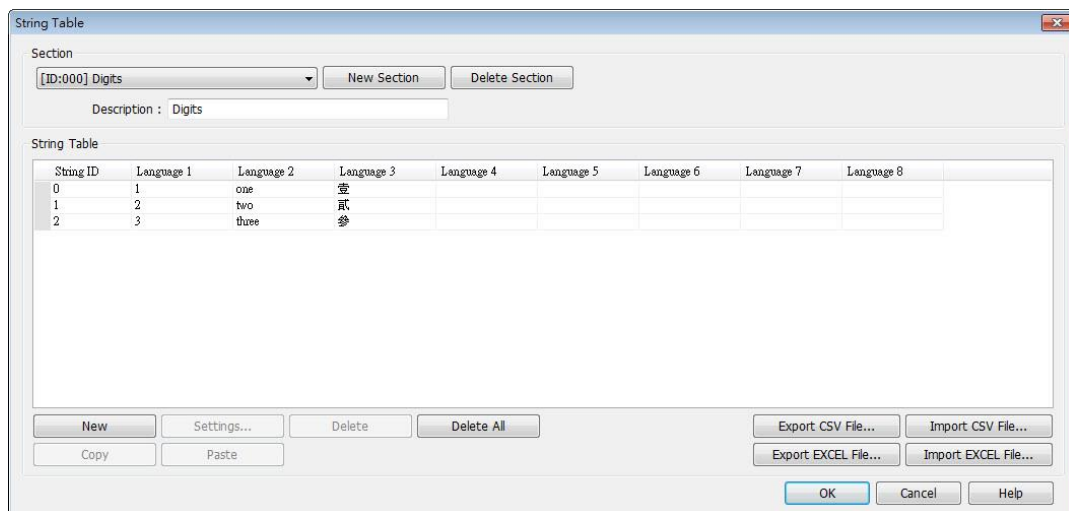

Setting	Description
Section	A list of all the existing String Tables. [New Section] Add a new String Table. [Delete Section] Delete the selected String Table.
New	Add a new string in the table.
Settings	Set the content of the selected string.
Export CSV File...	Export all the existing String Tables as a *.csv file.
Import CSV File...	Import *.csv file into the String Table.
Export EXCEL File...	Export all the existing String Tables as a *.xls file.
Import EXCEL File...	Import *.xls file into the String Table.

Note

- The font of each language in the String Table must be specified in Label Text Library.

- Number of rows from all sections combined is limited to 10000.

Example 1

1. Create a String Table using the same settings as the preceding figure.
2. Create a Text object, select [Use string table] check box. In String ID group box, select [Dynamic] and set read address to LW-0.

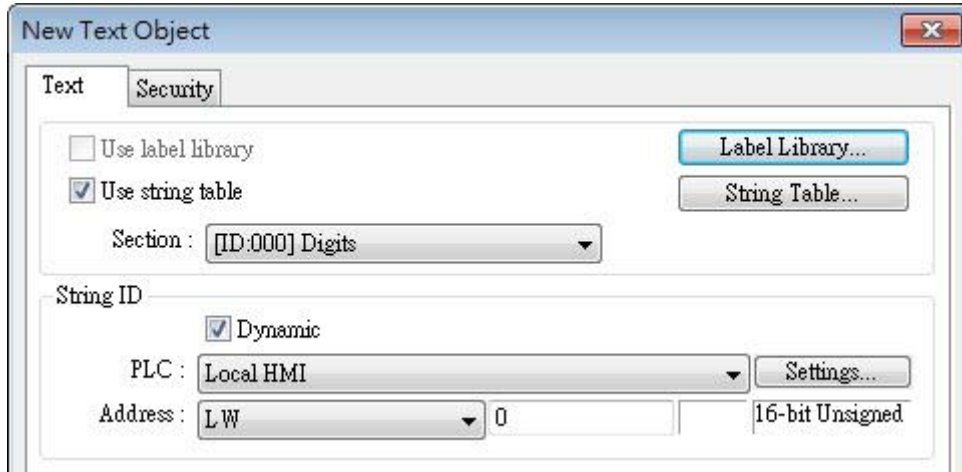

3. Create a Numeric object, set address to LW-0.
4. When the value in LW-0 is 0, the No. 0 string is displayed; when the value in LW-0 is 1, the No. 1 string is displayed.

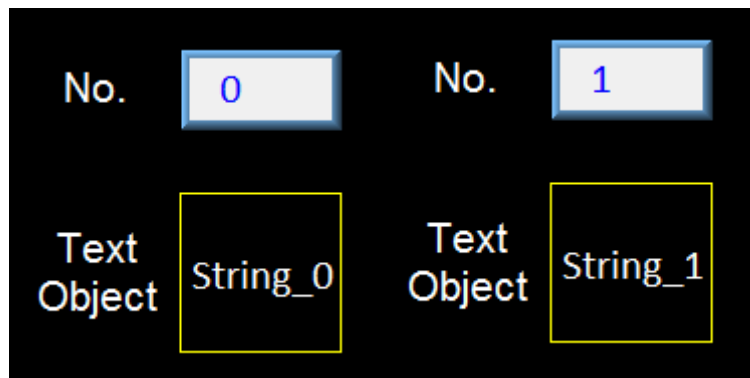

13.44. Database

13.44.1. Database Server

13.44.1.1. Overview

Database Server object enables connection with MySQL or MS SQL database server, allowing users to send data log or event log to the database, or use SQL Query to access data from the database.

13.44.1.2. Configuration



Click the Database Server icon on the toolbar to create a Database Server object. Or, click [Data/History] » [Database Server] in the menu.

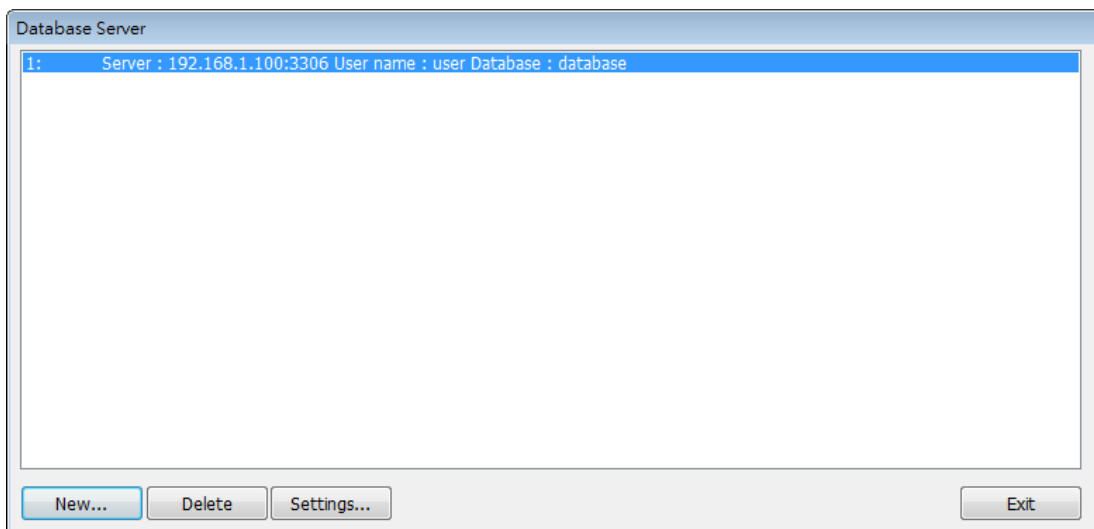

General Tab

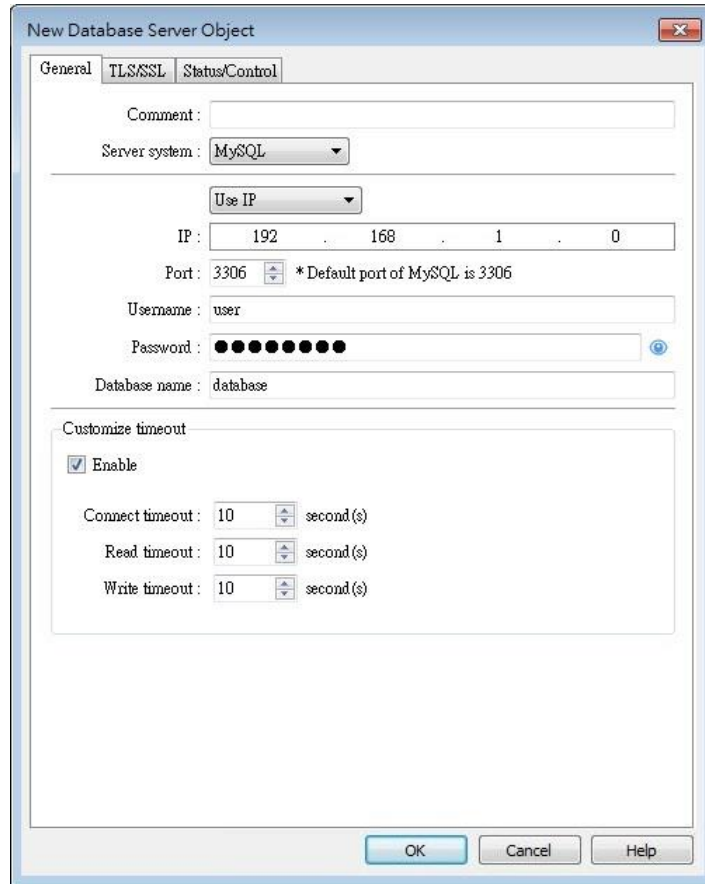

Setting	Description
Server system	Supported server systems: MySQL, MS SQL Server
IP	Enter the IP address of the database.
Use domain name	<div style="text-align: right; margin-bottom: 5px;"> <input type="button" value="Use domain name"/> </div> Domain name : <input type="text" value="127.0.0.1"/> <p>Supports designating a server using a domain name.</p>
Use server name	Server system : <input type="button" value="MS SQL Server"/> <hr/> <div style="text-align: right; margin-bottom: 5px;"> <input type="button" value="Use server name"/> e.g. HOSTSQUEXPRESS </div> Server name : <input type="text" value="PC_NAME\INSTANCE_NAME"/> <p>This option is only available when the selected server system is MS SQL Server. An instance stands for a communication port number, and the port number can be used to identify multiple database servers on the same computer.</p> <p>A server name can be in one of the following formats.</p> <ul style="list-style-type: none"> • <Computer name>\<Instance name>

	<ul style="list-style-type: none">• <Computer name> (Connect to Default Instance : MSSQLSERVER)• <IP address>\<Instance name>• <IP address> (Connect to Default Instance : MSSQLSERVER)
Port	Enter the port number of the database.
Username	Enter the username for connecting the database. The maximum is 32 words.
Password	Enter the password for connecting the database. The maximum is 32 words.
Database name	Enter the name of the database for collecting historical data.
Customize timeout	Timeouts for the following operations can be customized. Connect timeout The timeout for connection attempts. Connection attempts will be terminated when the timeout is reached. Read timeout The timeout for read operations. Write timeout The timeout for write operations.

TLS/SSL Tab

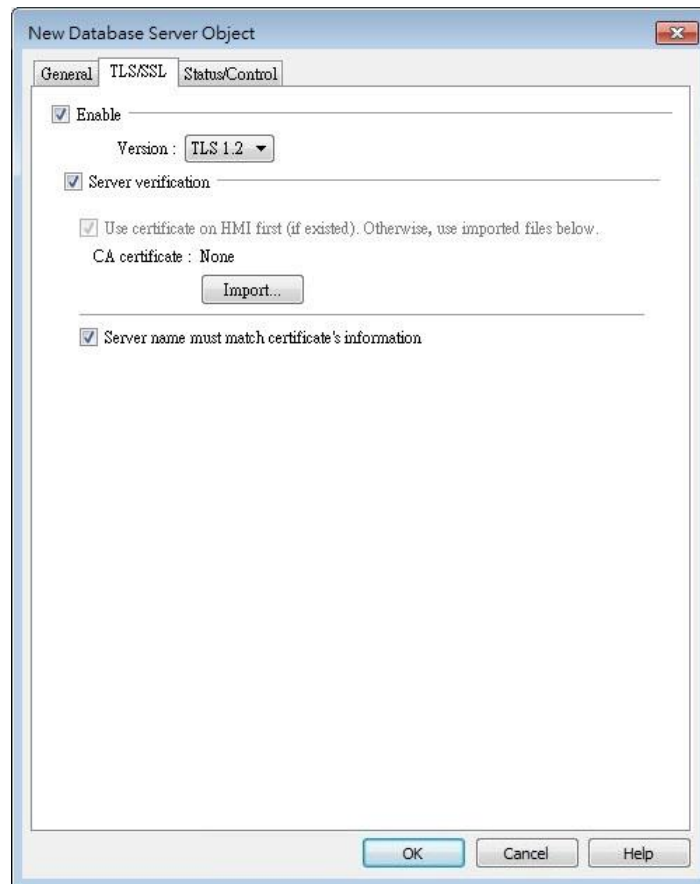

Setting	Description
Enable	Enable TLS/SSL security. TLS version can be selected from: TLS 1.0, TLS 1.1, and TLS 1.2.
Server verification	<p>Enable</p> <p>Verify whether the server certificate is signed by CA (certificate authority) certificate. Server certificate is sent from server during connection.</p> <p>Server name must match certificate's information</p> <p>Verify whether the server's domain name or IP matches the records in the server certificate. Domain name and IP records are stored in Subject Alternative Name of the certificate.</p>

Status/Control Tab

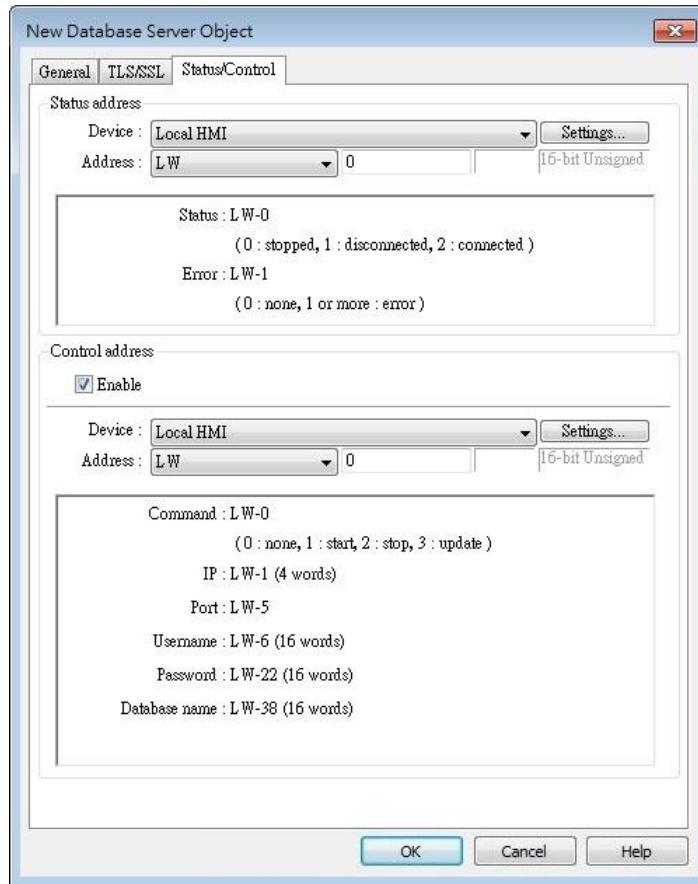

Setting

Description

Status address

LW-n: Displays the connection status of Database Server.

Value	Description
0	Not attempting to connect to database.
1	Failed to connect to database.
2	Connection succeeded.

LW-n+1: Error indicator.

Value	Description
0	No error.
1	Unknown error.
2	Failed to connect to database.
3	Database blocks the unauthorized connection.
4	Incorrect database name.
5	Invalid domain name.
6	Exceeded connection limit.

Control address

LW-n: Controls the operation of Database Server.

Value	Description
0	Ready
1	Start
2	Stop
3	Update

LW-n+1: Sets the IP address of the database.
 LW-n+5: Sets the port number of the database.
 LW-n+6: Sets the username for connecting database.
 LW-n+22: Sets the password for connecting database.
 LW-n+38: Sets the name of the database for collecting historical data.

Note

- If sampled data is successfully synchronized to the SQL database, three tables will be generated in the database, and the sampled data is saved in *_data table.

Table	Description
<HMI NAME> <DATALOG NAME>_data	Saves data sampling
<HMI NAME> <DATALOG NAME>_data_format	System folder
<HMI NAME> <DATALOG NAME>_data_section	System folder

- When synchronizing event log, the three tables generated in the database are listed as the following table, and the event log is saved in *_event table.

Table	Description
<HMI NAME>_event	Saves event log
<HMI NAME>_event_log	System folder
<HMI NAME>_event_update_time	System folder

- If the content of data sampling / event log, such as data format or event message, is changed and downloaded to HMI, please delete the tables listed above first, and then the new content will thus be effective.
- Azure SQL Server is supported. To use Azure SQL Server, select MS SQL as server system and use domain name. Azure SQL Server has firewall settings, please add the client into whitelist, and see how to configure by opening the link below:
<https://docs.microsoft.com/en-us/azure/azure-sql/database/single-database-manage#manage-an-existing-server>

Example 1

1. Create a Database Server object, set Status Address to LW-0, and Control Address to LW-10.

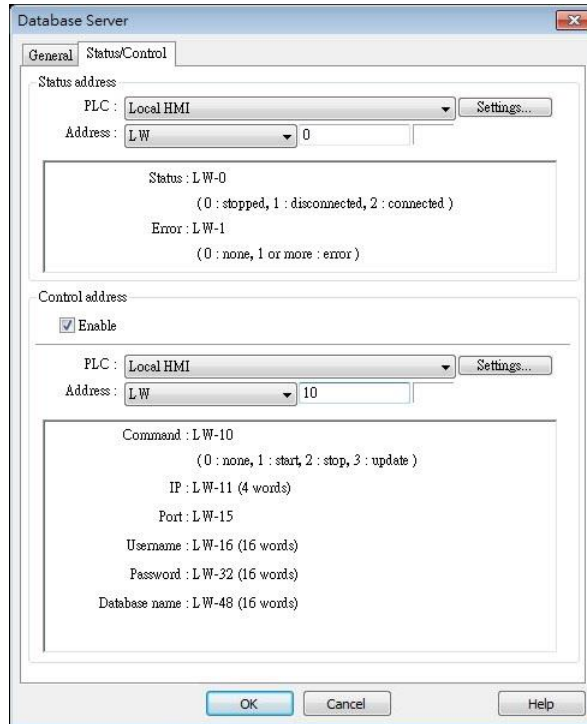

2. Create a Data Sampling object, in [Sync. to database] group box select [Enable], and set Control Address to LW-80, to update or clear HMI historical data.

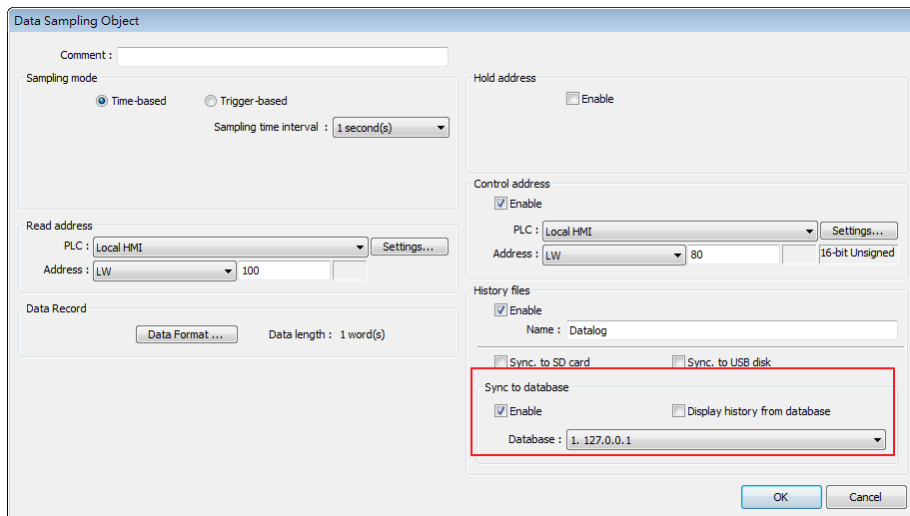

3. If the database is successfully connected, the status indicator LW-0 displays 2 (connection succeeded), and the error indicator LW-10 displays 0 (no error).
4. Write 2 in LW-80 (sync. data). Open SQL database, the data can be found in table <HMI NAME>_<DATALOG NAME>_data.

	Table	Action	Records	Type	Collation	Size	Overhead
<input type="checkbox"/>	hostname_datalog_data		6	MyISAM	utf8_unicode_ci	2.1 KiB	-
<input type="checkbox"/>	hostname_datalog_data_format		1	MyISAM	utf8_unicode_ci	2.0 KiB	-
<input type="checkbox"/>	hostname_datalog_data_section		0	MyISAM	utf8_unicode_ci	1.0 KiB	-
	3 table(s)	Sum	7	MyISAM	utf8_unicode_ci	5.2 KiB	0 B

13.44.2. SQL Query

13.44.2.1. Overview

SQL Query can exchange data with SQL database. Before enabling SQL Query, please configure Database Server.

13.44.2.2. Configuration



Click [Data/History] » [SQL Query] to open the settings dialog box. Configure the parameters and click OK; a SQL Query will be created.

General Tab

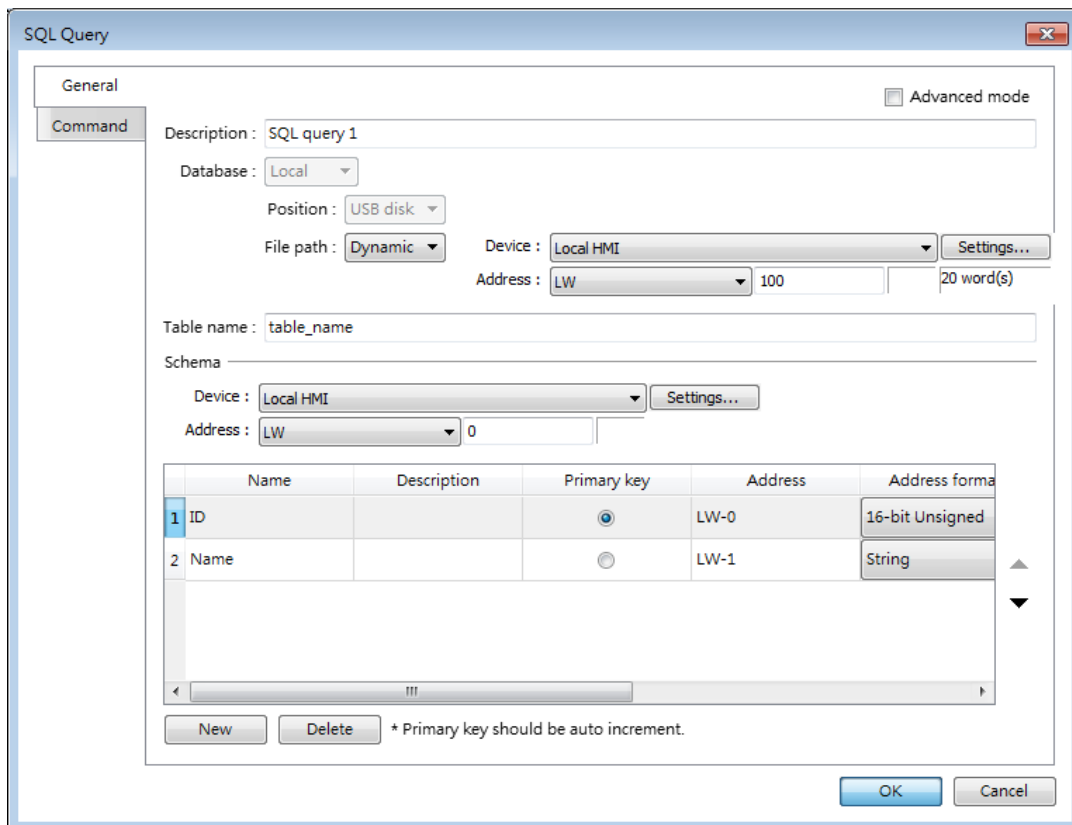

Setting	Description
Advanced Mode	<p>Without [Advanced Mode] selected: Click [New] to add a new row or click [Import from server] to import an existing database.</p> <p>With [Advanced Mode] selected: Manually enter syntax in Command tab to control MySQL/MS SQL database. Please note that returning from Advanced Mode to General Mode is not</p>

	possible.
Description	User's description about this query.
Database	Select the source database to read from. Local: The source database is the SQLite database stored in a USB disk or SD card attached to HMI. Remote: The source database is the designated Database Server.
File path	Use [Static] or [Dynamic] directory for a local database. When [Static] is selected, please enter the directory in this dialog box. When [Dynamic] is selected, please designate an address as the data source for the file path.
Table name	Enter the name of this query table.
Schema	The data read from database will be filled into the corresponding address specified in the schema. Please manually set Address Format after reading data.

Note

- A Primary Key should contain only numeric values.
- In MySQL, Auto Increment must be enabled for Primary Key.

Column Name	Datatype	PK	NN	UQ	B	UN	ZF	AI	G	Default/Expression
data	INT(11)	<input checked="" type="checkbox"/>	<input checked="" type="checkbox"/>	<input type="checkbox"/>	<input type="checkbox"/>	<input type="checkbox"/>	<input type="checkbox"/>	<input checked="" type="checkbox"/>	<input type="checkbox"/>	

Column Name: <input type="text" value="data"/>	Data Type: <input type="text" value="INT(11)"/>
Collation: <input type="text" value="Table Default"/>	Default: <input type="text"/>
Comments: <input type="text"/>	Storage: <input type="radio"/> Virtual <input type="radio"/> Stored
	<input checked="" type="checkbox"/> Primary Key <input checked="" type="checkbox"/> Not Null <input type="checkbox"/> Unique
	<input type="checkbox"/> Binary <input type="checkbox"/> Unsigned <input type="checkbox"/> Zero Fill
	<input checked="" type="checkbox"/> Auto Increment <input type="checkbox"/> Generated

Command Tab

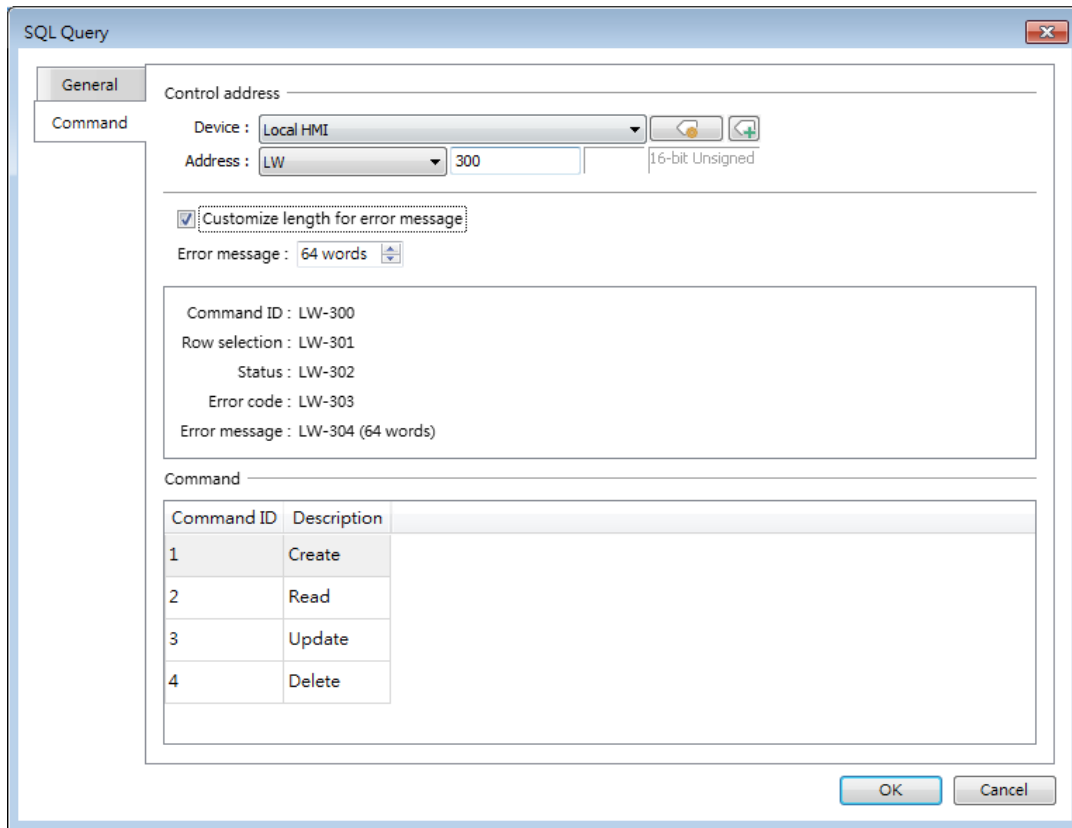

Setting	Description
Control address	Designate five consecutive registers to execute SQL commands and show results. Of the results, the length of error message can be customized.
Command	In standard mode (without checking Advanced mode box), the four basic commands of SQL (Create, Read, Update, and Delete) and their command ID are shown.

13.44.2.3. Advanced Mode

In the Command table in Advanced Mode, [No. of arguments], [No. of outputs], and [Action] columns can be found. Outputting multiple results to consecutive addresses at a time is possible.

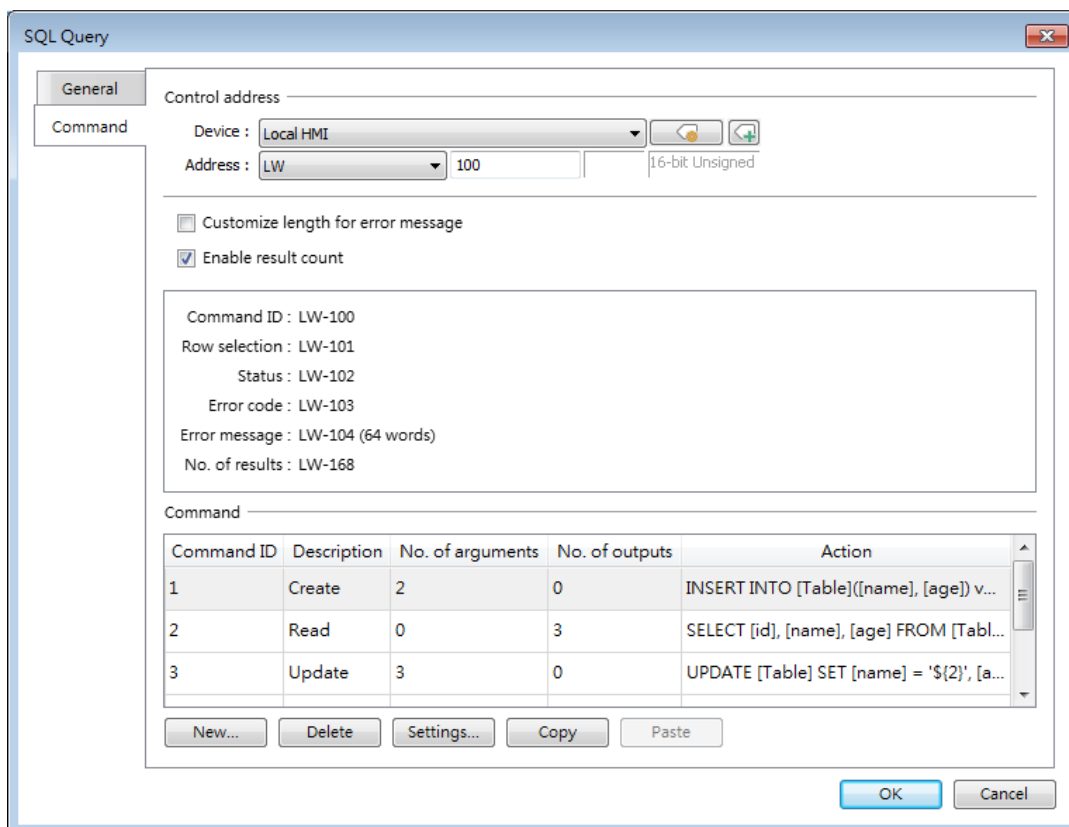

Setting	Description
Control address	Specify the ID number used to give this command.
Row selection	Specify a row.
Status	Displays the execution status. See Ch13.44.2.4.
Error code	Displays the execution result. See Ch13.44.2.5.
Error message	Displays the error message sent from database server. The default length of the error message is 64 words. Customizing the length of the error message is also possible, and the upper limit is 200 words.
No. of results	Displays the number of output results.
New / Delete / Settings / Copy	Add, delete, set, or copy a SQL Query command.

Query Tab

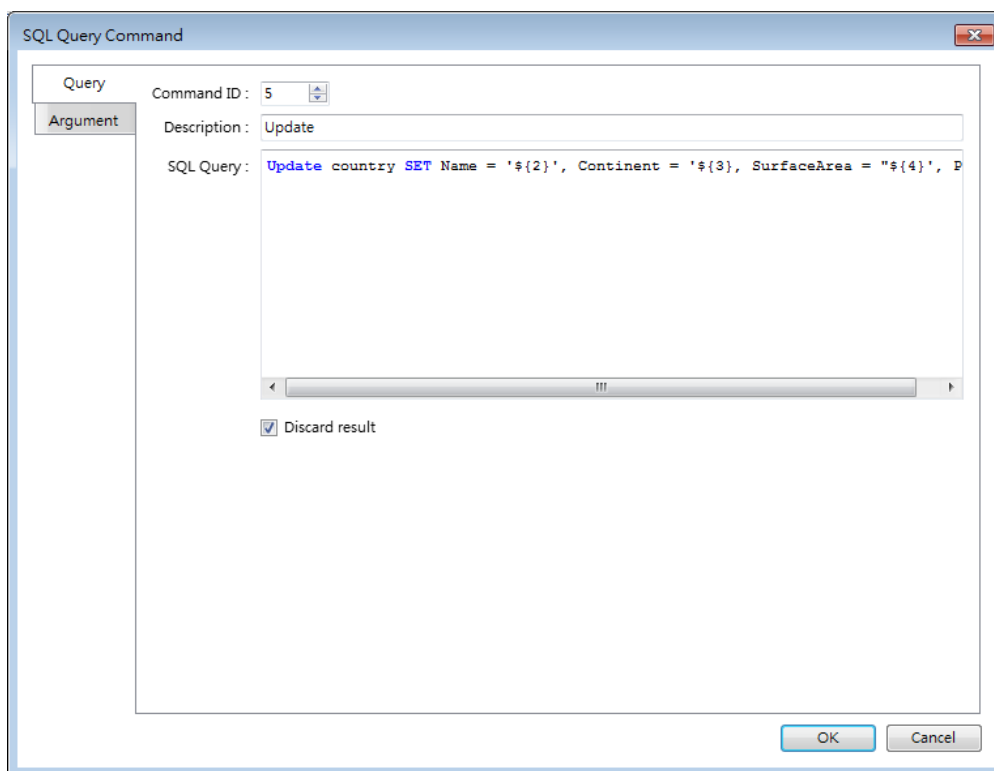

Setting	Description
Command ID	Specify the ID number used to give this command.
Description	Enter the description of this command.
SQL Query	Enter the syntax for this command. An argument should be enclosed in braces: <i>\${argument no.}</i>
Discard result	With this checkbox selected, the result of executing this command will not be shown in SQL Query Result Viewer object. This checkbox can be selected for commands that are done directly to the database without the need for returning a result, such as INSERT INTO, UPDATE, DELETE...etc.

Argument Tab

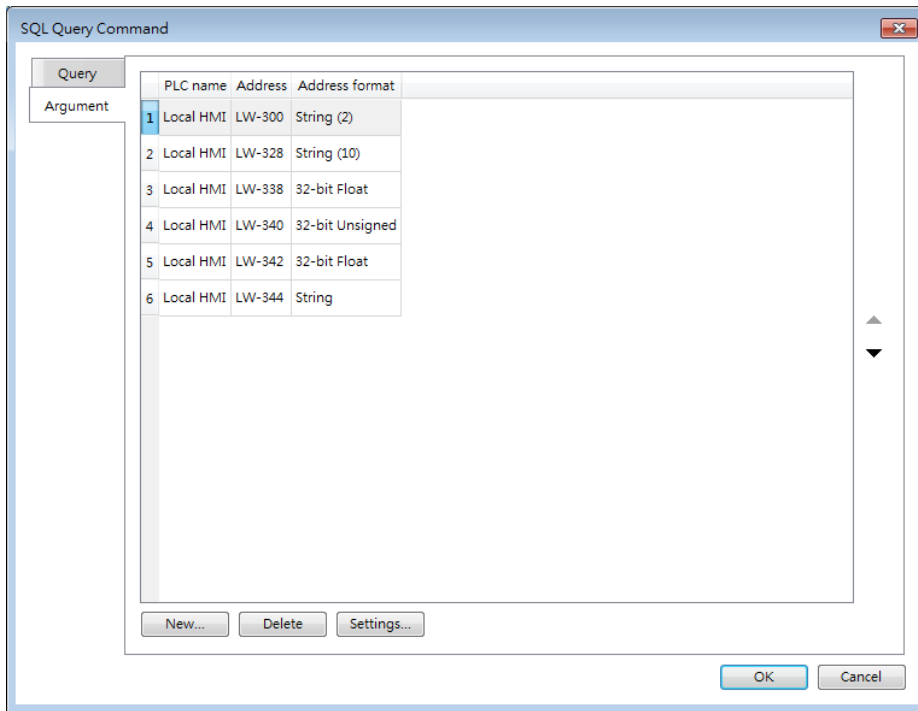

If argument is used in the syntax of a command in [Query] tab, the system will refer to the address specified in this tab according to the argument number enclosed in $\${argument\ no.}$.

Output Tab

When performing a database query in Advanced Mode, the query results will be sequentially stored at the addresses specified on the [Output] settings page. If the [Multiple results] option is selected, the system will output the query results in bulk to a series of consecutive addresses.

[Multiple results] not selected

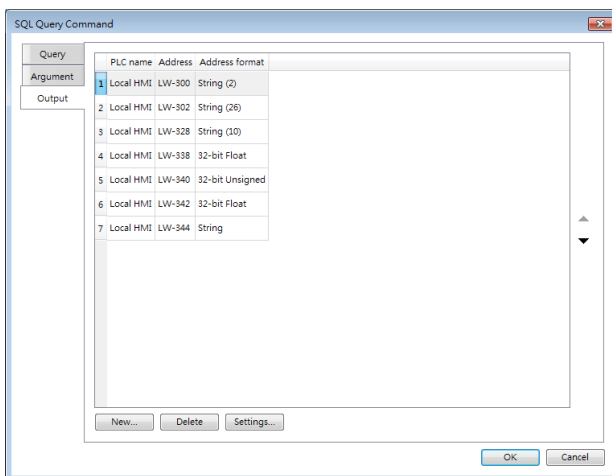

[Multiple results] selected

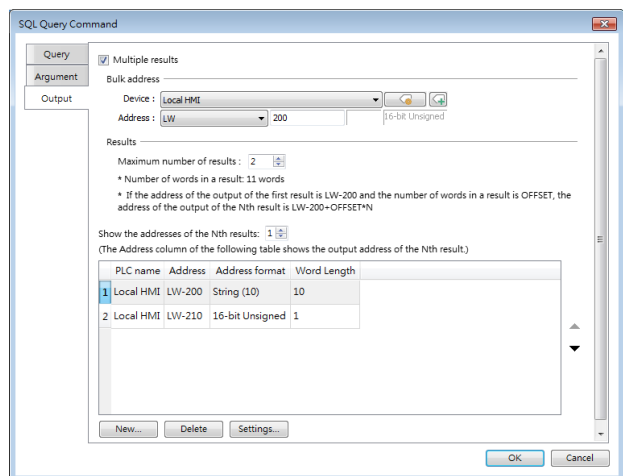

Setting	Description
Bulk address	The starting output address for the database query results.
Maximum number of results	The [Maximum number of results] can limit the number of outputs from the database query, with an upper limit of 1000 results. The fields included in each query result, and their address format and word length need to be specified. Note that [Maximum number of results] x [No. of outputs] cannot exceed 10000, meaning a maximum of 10000 addresses can be used for output. For example, if the maximum number of results is set to 100, and the query returns 300 results: When [Row selection] is set to 20, the 20 th ~119 th results will be output to the bulk addresses. When [Row selection] is set to 260, the 260 th ~299 th results will be output to the bulk addresses.
Show the addresses of the Nth results	Shows the output address of the N th result in the Address column of the table below this setting. If the address of the output of the first result is LW-200 and the number of words in a result is OFFSET, the address of the output of the N th result is LW-200+OFFSET*N.

13.44.2.4. Status

Value	Meaning
0	Normal
1	Query result exceeds 1000 records. Using LIMIT clause can constrain the number of rows in one page.

13.44.2.5. Error Code

Error Code	Meaning
0	No mistakes
1	Unknown error
2	Invalid command
3	Database Server is not connected yet
4	Argument cannot be read
5	Cannot write and output
6	Incorrect number of arguments

7	Error in MySQL, please read error message
8	Unsupported datatype
9	Number of columns exceeds the limit
10	Number of rows exceeds the limit
11	Unable to read local database directory
12	Name of local database does not exist
13	Internal error

13.44.2.6. Converting Datatype

Converting datatype as shown in the following table will take place after reading MySQL database. If conversion cannot run properly, error code 5 will show. For example, when converting MySQL's INT into EasyBuilder Pro's 16-bit Unsigned, if the value exceeds the limit of 16-bit Unsigned, error code 5 will show.

MySQL data format	EasyBuilder Pro datatype
TINYINT	16/32-bit BCD
SMALLINT	16/32-bit HEX
MEDIUMINT	16/32-bit Binary
INT	16/32-bit Signed
BIGINT	16/32-bit Unsigned
BIT	
FLOAT	32-bit Float
DOUBLE	
DECIMAL	
DATETIME	String
CHAR, BINARY	
VARCHAR, VARBINARY	
TINYBLOB, TINYTEXT	
BLOB, TEXT	
MEDIUMBLOB, MEDIUMTEXT	
LONGBLOB, LONGTEXT	

13.44.3. SQL Query Result Viewer

13.44.3.1. Overview

SQL Query Result Viewer shows the results obtained by running SQL Query.

13.44.3.2. Configuration



Click on [Data/History] » [SQL Query Result Viewer] to open the settings dialog box. Configure the parameters and click OK; a SQL Query Result Viewer will be created.

General Tab

Setting	Description
Comment	User's comment about this result viewer.
SQL Query	Select an existing SQL Query to show its result.
Style/ Style Color	Select a style and a color for this result viewer.
Text	Set the font, font size, and font color for the texts shown in this result viewer.

Caption	Set the font size and font color for the caption of this result viewer.
Table	This group box opens when selecting Default as style. The attributes of the result query table can be configured.
Filter enabled	With this checkbox selected, entering keywords in SQL Query Result Viewer to search for specific text is possible.

13.45. Dynamic Scale

13.45.1. Overview

Dynamic Scale offers customizable tick marks and scale labels and can be used together with objects such as Trend Display, Bar Graph..., etc.

13.45.2. Configuration



Click the Dynamic Scale icon on the toolbar to open a Dynamic Scale object property dialog box. Set up the properties, press OK button, and a new Dynamic Scale object will be created.

General Tab

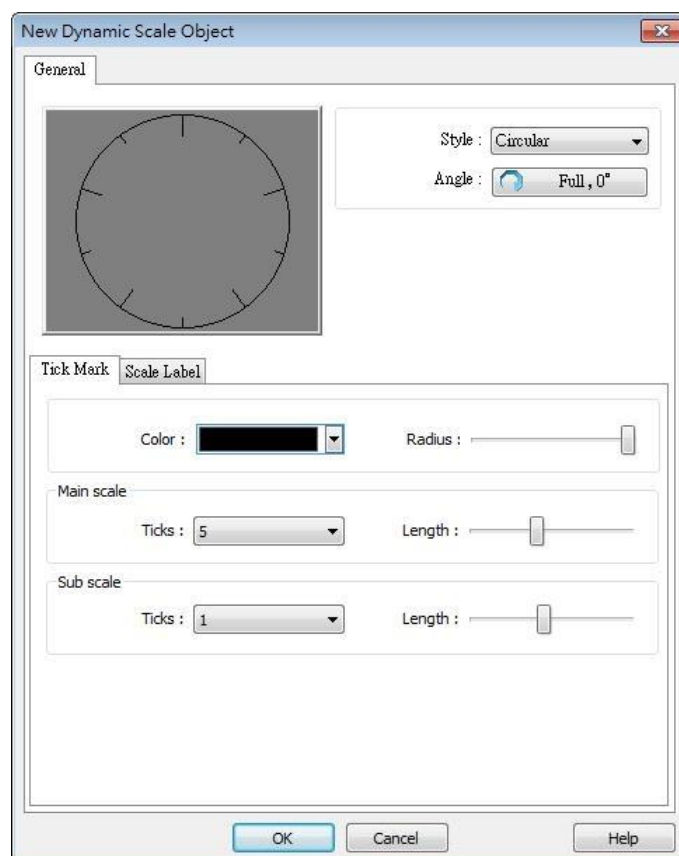

Setting	Description
Style	Select the style from [Circular], [Horizontal], or [Vertical]. If select [Circular], set the [Direction] and [Degree].

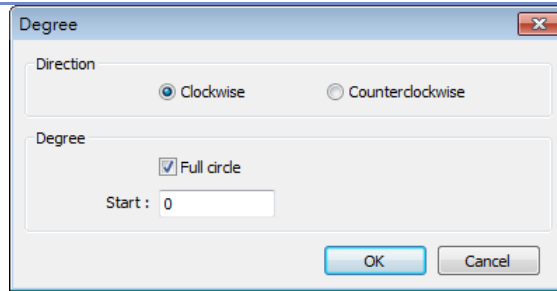
**Direction**

Select from [Clockwise] or [Counterclockwise].

Degree

If [Full circle] is selected, set the start degree.

If [Full circle] is not selected, set the start and end degree.

**Tick Mark**

Select the color of the tick mark, and set the number of ticks for the main and sub scale (major and minor tick mark).

For [Circular] style, the length of the major and minor tick mark, and the radius of the circular tick mark can be set.

Scale Label

Displays major tick labels.

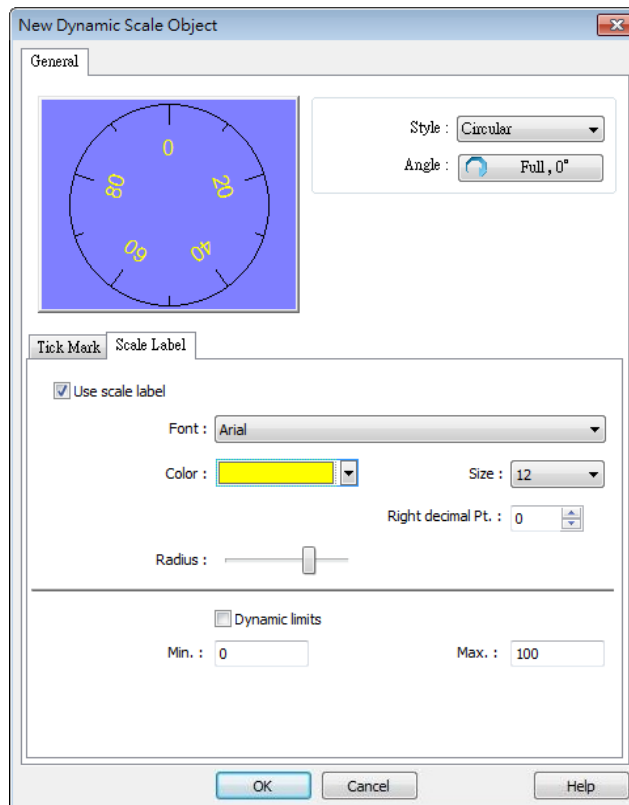
Circular

Set the font, font color, font size, and decimal point of the scale label.

Set the radius start from the center of the object to the position to place the scale label.

Vertical / Horizontal

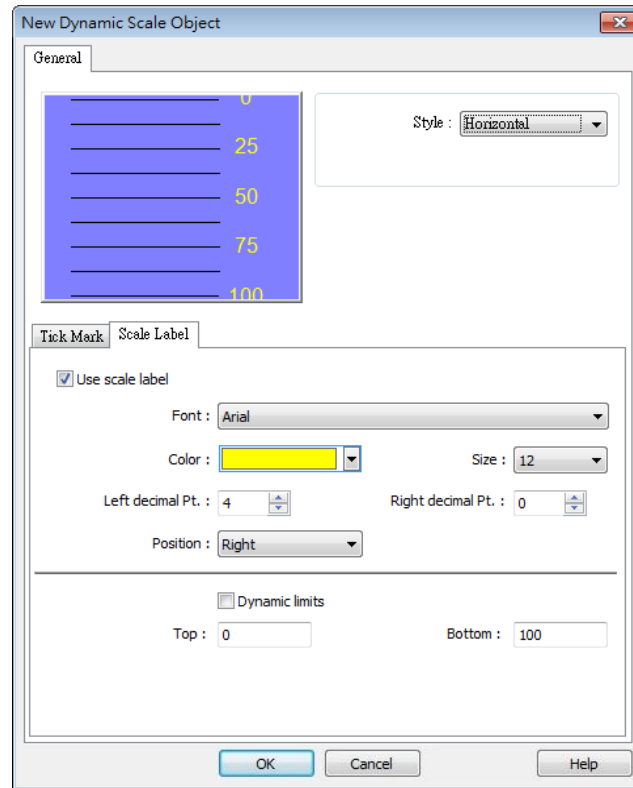

Set the font, font color, font size, and decimal point of the scale label.
Set the position to display the scale label.

The Max. and Min. limits of the scale label can be specified. If [Dynamic limits] is selected, the Max. and Min. limits can be set by the designated word addresses.

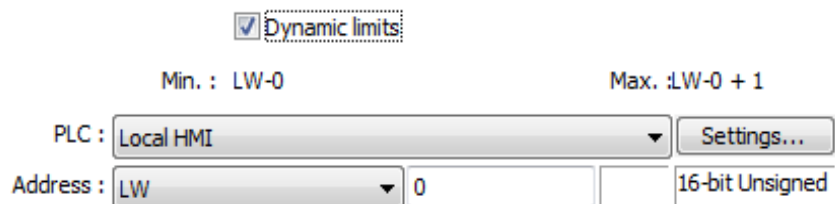

13.46. Dynamic Drawing

13.46.1. Overview

Dynamic Drawing object enables drawing a shape in a specified region on HMI screen at run time. The shape can be a line, a rectangle, a circle, or a dot. By setting the Attributes Addresses, the style and the color of the shape can be customized.

13.46.2. Configuration



Click the Dynamic Drawing icon on the toolbar to open a Dynamic Drawing object property dialog box. Set up the properties, press OK button, and a new Dynamic Drawing object will be created.

General Tab

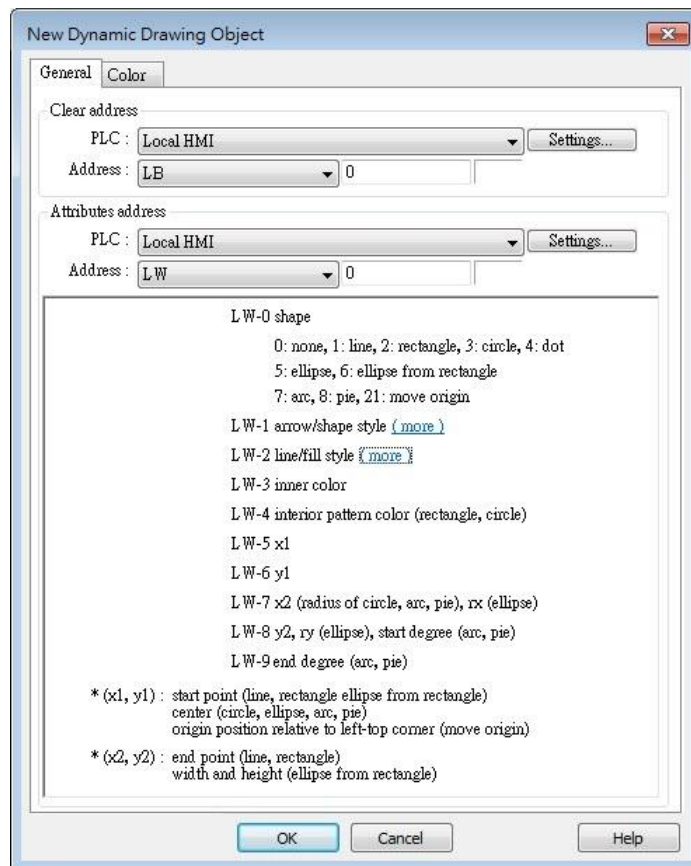

Setting	Description
Clear Address	Clears the drawing.

Attributes Address Changes the attributes in the drawing.



















Entering different values in different Attributes Addresses brings different effects, as shown in the following table.

Attributes Address	Attributes Address+0	Attributes Address+1		Attributes Address+2	Attributes Address+3	Attributes Address+4
Default	0	Ones	Tens		Customizable	Customizable
Line	1	0: Non-arrow	0: Small	0: Solid line	Line color	
		1: Single-ended arrow (Hollow)	1: Large	1: Dashed line		
		2: Double-ended arrow (Hollow)		2: Dotted line		
		3: Single-ended arrow (Solid)		3: Dash Dot line		
		4: Double-ended arrow (Solid)		4: Dash Dot Dot line		
				5 and up: Solid line with thicknesses greater than 2		
Rectangle	2	0: Hollow		Drawn in Line mode	Rectangle color	Interior pattern color
		1: Solid		Drawn in Pattern mode		
Circle	3	0: Hollow		Drawn in Line mode	Circle color	Interior pattern color
		1: Solid		Drawn in Pattern mode		
Dot	4				Dot color	
Ellipse	5	0: Hollow		Drawn in Line mode	Ellipse color	Interior pattern color
		1: Solid		Drawn in Pattern mode		
Ellipse from Rectangle	6	0: Hollow		Drawn in Line mode	Ellipse color	Interior pattern color
		1: Solid		Drawn in Pattern mode		
Arc	7			Drawn in Line mode	Arc color	
Pie	8	0: Hollow		Drawn in Line mode	Pie color	Interior pattern color
		1: Solid		Drawn in Pattern mode		
Move Origin	21					

Attributes Address	Attributes Address+0	Attributes Address+5	Attributes Address+6	Attributes Address+7	Attributes Address+8	Attributes Address+9
Default	0					
Line	1	Start point X	Start point Y	End point X	End point Y	
Rectangle	2	Left-top point X	Left-top point Y	Right-bottom point X	Right-bottom point Y	
Circle	3	Center point X	Center point Y	Radius		
Dot	4	Dot X	Dot Y			

Ellipse	5	Center point X	Center point Y	Radius on the X axis	Radius on the Y axis	
Ellipse from Rectangle	6	Left-top point X	Left-top point Y	Width	Height	
Arc	7	Center point X	Center point Y	Radius	Start degree	End degree
Pie	8	Center point X	Center point Y	Radius	Start degree	End degree
Move Origin	21	New origin X	New origin Y			

The values in [Attributes Address+2] represent different Line or Pattern styles, as shown in the following table.

Line mode	Pattern mode
0 	0 
1 	1 
2 	2 
3 	3 
4 	4 
5 	5 
6 	6 
⋮	7 
19 	8 
	9 
	10
	11
	12
	13
	14
	15
	16
	17
	18
	19
	20
	21
	22
	23
	24
	25
	26

Color Tab

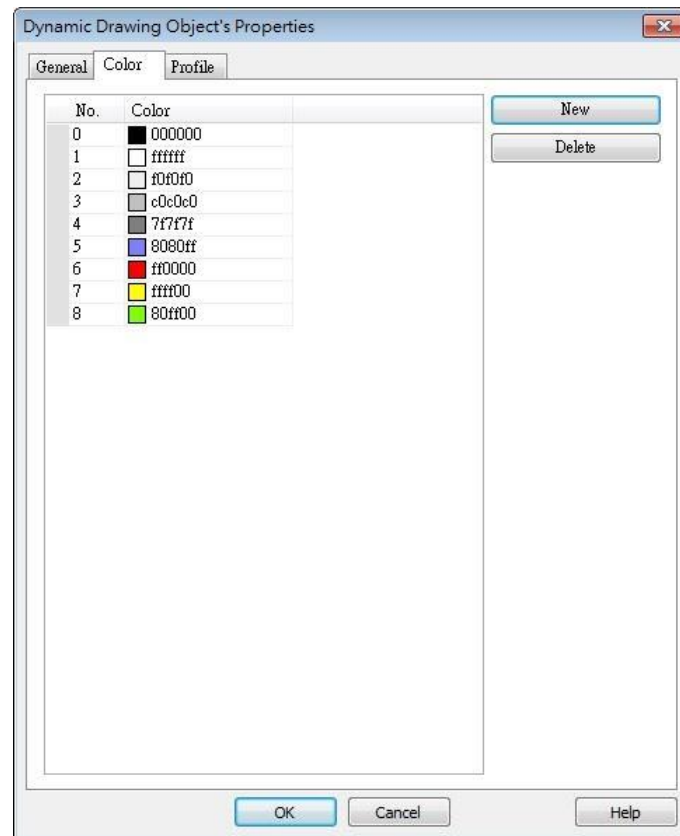
**Setting****Description****New**

Adds a color to be used in the drawing.

Delete

Deletes the selected color.

Example 1

The following demo project demonstrates how to dynamically draw an arrow or a circle on HMI screen. To build the project, follow these steps:

1. Create a Dynamic Drawing object, set Clear Address to LB-0, and Attributes Address to LW-0.
2. Create a Toggle Switch object, set address to LB-0, and select Toggle as switch style, for clearing the drawing.
3. Create 10 Numeric objects, set addresses to LW-0~LW-9, for specifying the attributes in the drawing.
4. Run simulation or download the project to HMI to see the result. By entering 1 in LW-0, a line is drawn, and entering different values in LW-1~9 can change the style, the color, and the position of the line.

Demo Project - Dynamic Drawing
-> Dynamically changing pattern on HMI!

Attributes + 0: shape
0: none, 1: line, 2: rectangle,
3: circle, 4: dot, 5: ellipse,
6: ellipse from rectangle,
7: arc, 8: fan, 21: reset start

0000

0001 Attributes + 1: arrow/shape style

0001 Attributes + 2: line/fill style

0005 Attributes + 3: inner color

0000 Attributes + 4: interior pattern color
(rectangle, circle, ellipse, fan)

0000 Attributes + 5: X1

0000 Attributes + 6: Y1

0300 Attributes + 7: X2(circle/arc/fan radius),
Rx(ellipse)

0300 Attributes + 8: Y2, Ry(ellipse),
Start circle(arc/fan)

0000 Attributes + 9: End circle(arc/fan)

Fast Sel

Clear Pattern

5. Press Clear Pattern button, and enter 3 in LW-0, a circle is drawn, and entering different values in LW-1~9 can change the style, the color, and the position of the circle.

Demo Project - Dynamic Drawing
-> Dynamically changing pattern on HMI!

Attributes + 0: shape
0: none, 1: line, 2: rectangle,
3: circle, 4: dot, 5: ellipse,
6: ellipse from rectangle,
7: arc, 8: fan, 21: reset start

0000

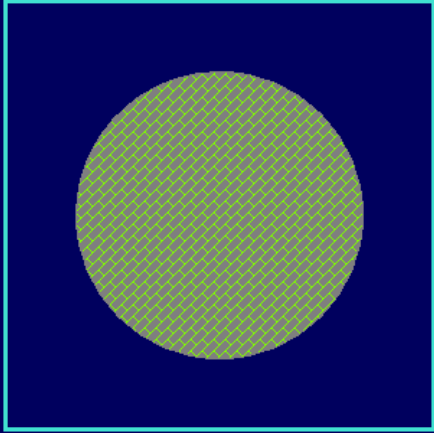

0001 Attributes + 1: arrow/shape style

0025 Attributes + 2: line/fill style

0004 Attributes + 3: inner color

0008 Attributes + 4: interior pattern color
(rectangle,circle,ellipse,fan)

0150 Attributes + 5: X1

0150 Attributes + 6: Y1

0100 Attributes + 7: X2(circle/arc/fan radius),
Rx(ellipse)

0000 Attributes + 8: Y2, Ry(ellipse),
Start circle(arc/fan)

0000 Attributes + 9: End circle(arc/fan)

Fast Sel

Clear Pattern

Note

- Before using Attributes Address, please define [Attributes Address + 1] ~ [Attributes Address + 9]. The system will reset the Attributes Address, after it is used.
- If the drawing is not cleared, the new drawing will overlap the previous one, and the maximum acceptable number of drawings in a Dynamic Drawing object is 1000.
- The maximum number of line styles is 19, which means the maximum thickness of a solid line is 16. The style numbers that exceed 19 will be displayed as 19.
- Find the color number in Color tab.
- The range of the start and end degree for Arc and Pie is 0 to 360 degrees.
- Origin position is relative to left-top corner (0,0). Giving "move origin" command will make (x1, y1) the new origin, and x1, y1 will keep on accumulating until being reset to (0,0) by clearing the drawing.
- If cMT Viewer is used to monitor a Dynamic Drawing object on a cMT / cMT X model, then PLW address is recommended to be used as the Attribute Address, so that drawing commands can be given to the cMT Viewer device's PLW addresses. This prevents the issue where the HMI and the cMT Viewer device show different drawing results.

13.47. PDF Reader

13.47.1. Overview

PDF Reader object enables viewing of PDF documents on HMI.

13.47.2. Configuration



Click the PDF Reader icon on the toolbar to create a PDF Reader object. Or, click [Object] » [Media] » [PDF Reader] in the menu.

General Tab

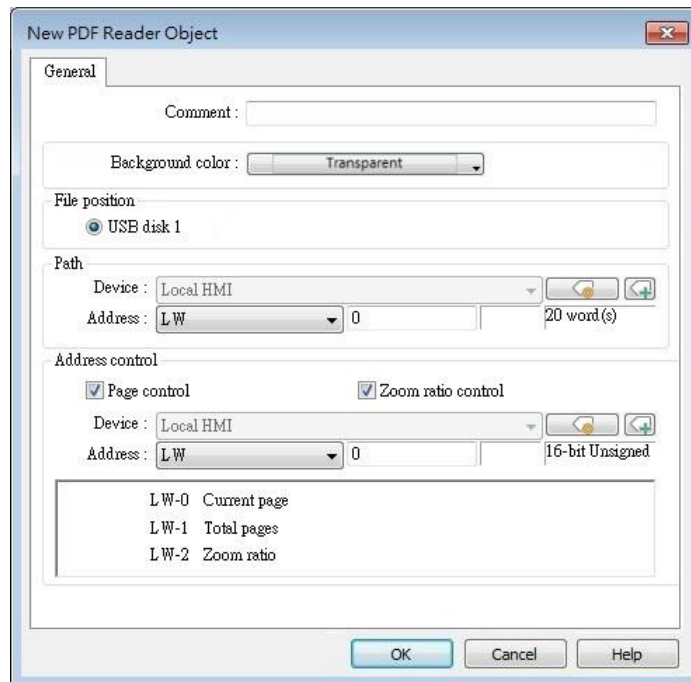

Setting	Description
File position	Select the position where the PDF file is stored.
Path	The directory of the PDF file stored in the external device.
Page Control	<p>Current page The page number of the current page. Set a value to change the current page.</p> <p>Total pages Total number of pages of the PDF file.</p>

Zoom ratio

Current zoom ratio. Set a value to change the zoom ratio. Unit: %; i.e., the number 100 indicates 100% display (1:1).

**Note**

- PDF Reader cannot be opened using simulation mode or cMT Viewer.
- The PDF files protected by passwords or restrictions cannot be read using PDF Reader.
- CPU loading may rise when multiple PDF Reader objects are opened simultaneously.
- When entering a page number in the Page Control register under multi-page view mode, the specified page will be opened in single-page view.
- Two-finger zoom in / out gestures are supported on capacitive touchscreens.

13.48. Table

13.48.1. Overview

Table object allows users to draw a table in the project window and customize the border, grid, and pattern of the table.

13.48.2. Configuration

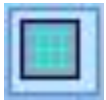

Click the Table icon on the toolbar to create a Table object. Or, click [Object] » [Table] in the menu.

General Tab

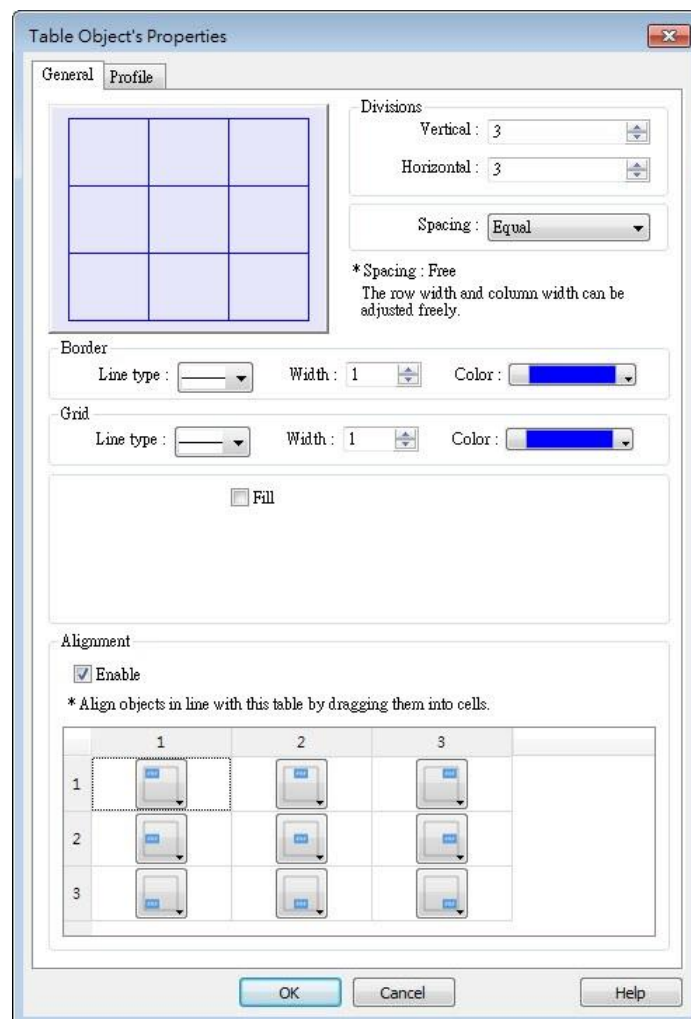

Setting	Description
Preview Window	Displays the settings result.
Vertical	Sets the number of columns in the table. Range: 1~255
Horizontal	Sets the number of rows in the table. Range: 1~255
Spacing	The available options are [Equal] and [Free]. When [Free] is selected, the user can manually adjust the column width or row height in the editing window.
Border	Sets the type, width, and color of the border. [Line width] setting is available only when Solid line type is selected. The range of width is 0~8. The line will become invisible when the width is set to 0.
Grid	Sets the type, width, and color of the grid. [Line width] setting is available only when Solid line type is selected. The range of width is 0~8. The line will become invisible when the width is set to 0.
Fill	Sets the pattern style and color.
Alignment	<p>By dragging the objects into the cells in the Table, the objects can align to the preset position. Different alignments can be set for each cell in the Table, by default the objects are center-aligned, and nine different alignments can be selected as shown in the screenshot of the settings window.</p> <p>With Alignment enabled, the maximum number of vertical / horizontal divisions is 32.</p> <p>Please note that this setting does not support the alignment of multiple groups of objects.</p>

13.49. VNC Viewer

13.49.1. Overview

VNC Viewer can run on HMI to control a PC or a device remotely. VNC server must be installed on the remote device to be connected. On HMI the user can monitor and control the remote device.

13.49.2. Configuration



Click on the VNC Viewer icon on the toolbar or select [Objects] » [Media] » [VNC Viewer] to open the settings dialog box. Configure the parameters and click OK; a VNC Viewer object will be created.

General Tab

Setting	Description
IP	Enter the IP address of the remote device to be

	connected.
Port	Enter the port number of the remote device to be connected.
Default Password	Enter the VNC password to log in the VNC server of the remote device. If Default Password is enabled, when connecting the remote device, VNC Viewer will automatically use the password specified here to log in, and the user doesn't need to enter the password.
Color level	<p>Select from four color levels: Full (all available colors), Medium (256 colors), Low (64 colors), Very low (8 colors).</p> <p>Auto select (not all servers support this function) Allow VNC Viewer to automatically detect and select the color level supported by the server used.</p> <p>Enable run-time modification in [Control] function Select color level or decide whether to enable [Auto select] in HMI runtime using the control addresses that can be specified in the Control tab in the VNC Viewer settings dialog box.</p>
Title bar	<p>Enable</p> <p>When [Enable] is selected, a field shows for entering the caption in the title bar. The caption is limited to ASCII characters, and the font cannot be customized. The caption can be selected from Label Tag Library. Only when the title bar is enabled can the VNC Viewer window be moved or resized by dragging.</p>
Option	<p>Enable input from system keypad</p> <p>With this option selected, a keypad icon shows in the upper right corner of the VNC Viewer object, and the system keypad can be opened by clicking this icon.</p>

 **Note**

- eMT/iE/XE/mTV: VNC Viewer is supported for OS version 20160418 or later.
- cMT / cMT X Series: VNC Viewer is supported only on cMT series HMI screen accessed locally, and for OS version 20180928 or later.
- VNC Viewer cannot be simulated in on-line simulation mode.

- VNC Viewer only mirrors the actual resolution of the VNC server device and does not support scaling.
- When [Default password] is selected, HMI's Virtual Keyboard can only be called out manually. If [Default password] is not selected, the Virtual Keyboard can pop up automatically.

Control Tab

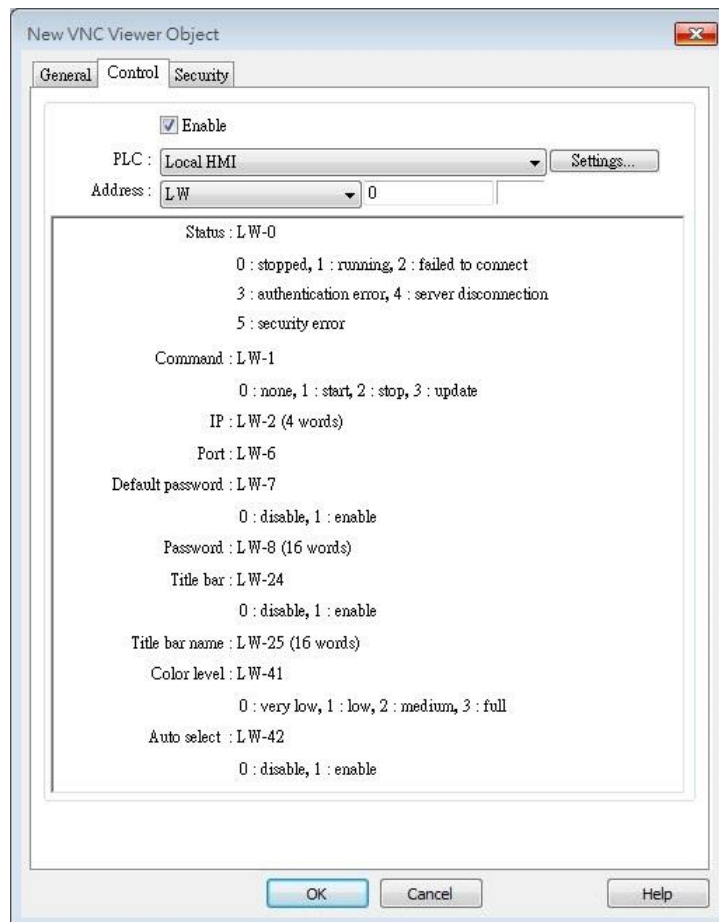

Setting	Description
IP	A set of word addresses can be specified to control VNC Viewer as well to display the connection status. Control address: Shows the connection status 0: Stopped 1: Running 2: Failed to connect 3: Authentication error 4: Server disconnection error 5: Security error Control address + 1: Command

0: None

1: Start

2: Stop

Control address+2~+5: IP

Control address+6: Port Number

Control address+7: Default Password

0: Disable

1: Enable

Control address+8: Password (16 words)

Control address+24: Title bar

0: Disable

1: Enable

Control address+25: Title bar name (16 words)

Control address +41: Color level

0: Very low

1: Low

2: Medium

3: Full

Control address +42: Auto select

0: Disable

1: Enable

Note

- The allowable value range that can be entered in Control Address+6 is 0~99. The actual Port Number will be the value entered in Control Address+6 plus 5900. For example, if the user enters 1 in Control Address+6, the actual Port Number will be 5901. However, if the user enters 100 in Control Address+6, the value will not be added by 5900, and the actual Port Number will be 100.
- In VNC Viewer, to use the HMI built-in Virtual Keyboard, please tap the Focus button on the Virtual Keyboard first, and then tap VNC Viewer screen. This will change the input target.

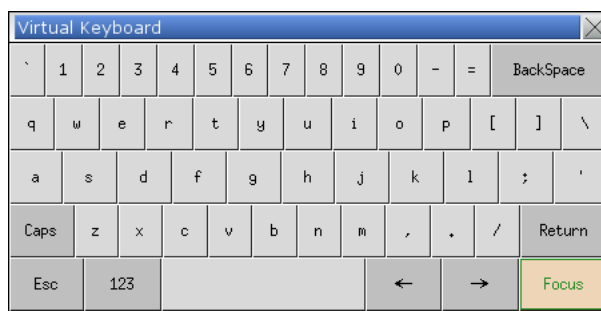

13.50. Contacts Editor

13.50.1. Overview

Contacts Editor enables users to dynamically add / modify / delete email contacts on HMI.

13.50.2. Configuration



Click the Contacts Editor icon on the toolbar to create a Contacts Editor object. Or, click [Objects] » [Contacts Editor] in the menu.

General Tab

The screenshot shows the 'New Contacts Editor Object' dialog box with the 'General' tab selected. The dialog has three sub-tabs: 'General', 'Outline', and 'Shape'. The 'General' tab contains the following fields and options:

- Control address:**
 - PLC: Local HMI (dropdown menu) with a 'Settings...' button to its right.
 - Address: LW (dropdown menu) and 0 (text input field).
- Command:** LW-0
 - 0 [None]
 - 1 [Add a contact to contacts list]
 - 2 [Delete a contact from contacts list]
 - 3 [Update mail address]
 - 4 [Add a contact to group]
 - 5 [Remove a contact from group]
 - 6 [Remove all contacts from group]
 - 7 [Display contacts in group]
 - 8 [Display contacts with no group]
 - 9 [Display all contacts]
- Result:** LW-1
 - 1 [Success]
 - 2 [Invalid command]
 - 3 [Contact not found]
 - 4 [Contact already exists]
 - 5 [Too many contacts]
 - 6 [Invalid name]
 - 7 [Invalid mail address]
 - 8 [Invalid group (equal to zero)]
 - 9 [Invalid group (exceed boundary)]
- Group(s):** LW-2
 - Name: LW-3 (32 word(s))
 - e-Mail: LW-35 (32 word(s))

At the bottom of the dialog, there is a note: '* Group(s) : bit 0 [Group A], bit 1 [Group B], bit 2 [Group C]...'. The dialog also features 'OK', 'Cancel', and 'Help' buttons at the bottom.

Setting	Description																																																				
Control Address	<p>A set of word addresses can be specified to change contact list or to show results.</p> <p>Control address: Gives commands.</p> <table border="1"> <thead> <tr> <th>Value</th> <th>Command</th> </tr> </thead> <tbody> <tr> <td>0</td> <td>None</td> </tr> <tr> <td>1</td> <td>Add a contact to contacts list</td> </tr> <tr> <td>2</td> <td>Delete a contact from contacts list</td> </tr> <tr> <td>3</td> <td>Update mail address</td> </tr> <tr> <td>4</td> <td>Add a contact to group</td> </tr> <tr> <td>5</td> <td>Remove a contact from group</td> </tr> <tr> <td>6</td> <td>Remove all contacts from group</td> </tr> <tr> <td>7</td> <td>Display contacts in group</td> </tr> <tr> <td>8</td> <td>Display contacts with no group</td> </tr> <tr> <td>9</td> <td>Display all contacts</td> </tr> </tbody> </table> <p>Control address + 1: Shows execution result.</p> <table border="1"> <thead> <tr> <th>Value</th> <th>Result</th> </tr> </thead> <tbody> <tr> <td>1</td> <td>Success</td> </tr> <tr> <td>2</td> <td>Invalid command</td> </tr> <tr> <td>3</td> <td>Contact not found</td> </tr> <tr> <td>4</td> <td>Contact already exists</td> </tr> <tr> <td>5</td> <td>Too many contacts</td> </tr> <tr> <td>6</td> <td>Invalid name</td> </tr> <tr> <td>7</td> <td>Invalid mail address</td> </tr> <tr> <td>8</td> <td>Invalid group (equal to zero)</td> </tr> <tr> <td>9</td> <td>Invalid group (exceed boundary)</td> </tr> </tbody> </table> <p>Control address + 2: Group(s), uses bits to represent groups.</p> <table border="1"> <thead> <tr> <th>Value</th> <th>Commands</th> </tr> </thead> <tbody> <tr> <td>0</td> <td>Group A</td> </tr> <tr> <td>1</td> <td>Group B</td> </tr> <tr> <td>2</td> <td>Group C</td> </tr> <tr> <td>3~15</td> <td>Group D ~ Group P</td> </tr> </tbody> </table> <p>Control address + 3: Name (32 word(s)), contact name</p> <p>Control address + 35: e-Mail (32 word(s)), e-mail address</p>	Value	Command	0	None	1	Add a contact to contacts list	2	Delete a contact from contacts list	3	Update mail address	4	Add a contact to group	5	Remove a contact from group	6	Remove all contacts from group	7	Display contacts in group	8	Display contacts with no group	9	Display all contacts	Value	Result	1	Success	2	Invalid command	3	Contact not found	4	Contact already exists	5	Too many contacts	6	Invalid name	7	Invalid mail address	8	Invalid group (equal to zero)	9	Invalid group (exceed boundary)	Value	Commands	0	Group A	1	Group B	2	Group C	3~15	Group D ~ Group P
Value	Command																																																				
0	None																																																				
1	Add a contact to contacts list																																																				
2	Delete a contact from contacts list																																																				
3	Update mail address																																																				
4	Add a contact to group																																																				
5	Remove a contact from group																																																				
6	Remove all contacts from group																																																				
7	Display contacts in group																																																				
8	Display contacts with no group																																																				
9	Display all contacts																																																				
Value	Result																																																				
1	Success																																																				
2	Invalid command																																																				
3	Contact not found																																																				
4	Contact already exists																																																				
5	Too many contacts																																																				
6	Invalid name																																																				
7	Invalid mail address																																																				
8	Invalid group (equal to zero)																																																				
9	Invalid group (exceed boundary)																																																				
Value	Commands																																																				
0	Group A																																																				
1	Group B																																																				
2	Group C																																																				
3~15	Group D ~ Group P																																																				

 **Note**

- General tab cannot be found when the model used is a cMT / cMT X model.
- Contact names do not support Unicode.
- The number of groups is specified in [System Parameter Settings] » [e-Mail] » [Recipients]. Please note that the number of groups cannot be dynamically changed on HMI.

Outline

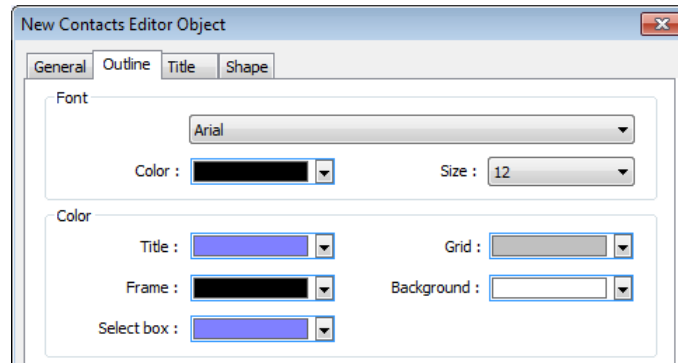

Setting	Description
Font & Color	Select Contacts Editor object's font and color.

Title

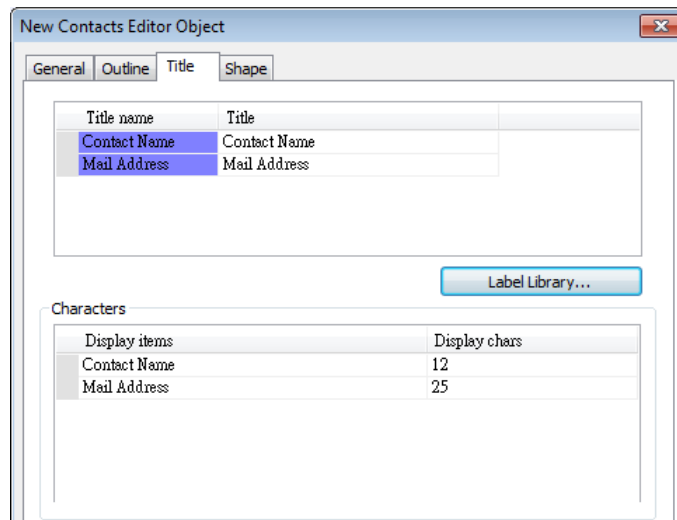

Setting	Description
Title	The title shown in Contacts Editor.
Display chars	The displayable data length of each title in Contacts Editor. Range: 1~60

13.51. Event Bar Chart

13.51.1. Overview

Event Bar Chart is a type of easy-to-use bar chart that can comprehensively illustrate project schedule. Using Event Bar Chart to illustrate HMI events or alarms can help users to clearly understand the time at which an event or alarm occurs, and its duration. Before drawing an Event Bar Chart, please configure Event Log object first.

This feature is only supported on cMT / cMT X Series models (excluding cMT-Gateway).

13.51.2. Configuration

13.51.2.1. Event Log

Click [Data/History] » [Event Log] in the menu to configure several event logs. This section describes the Event Bar Chart related settings that can be found in the Event Log settings dialog box.

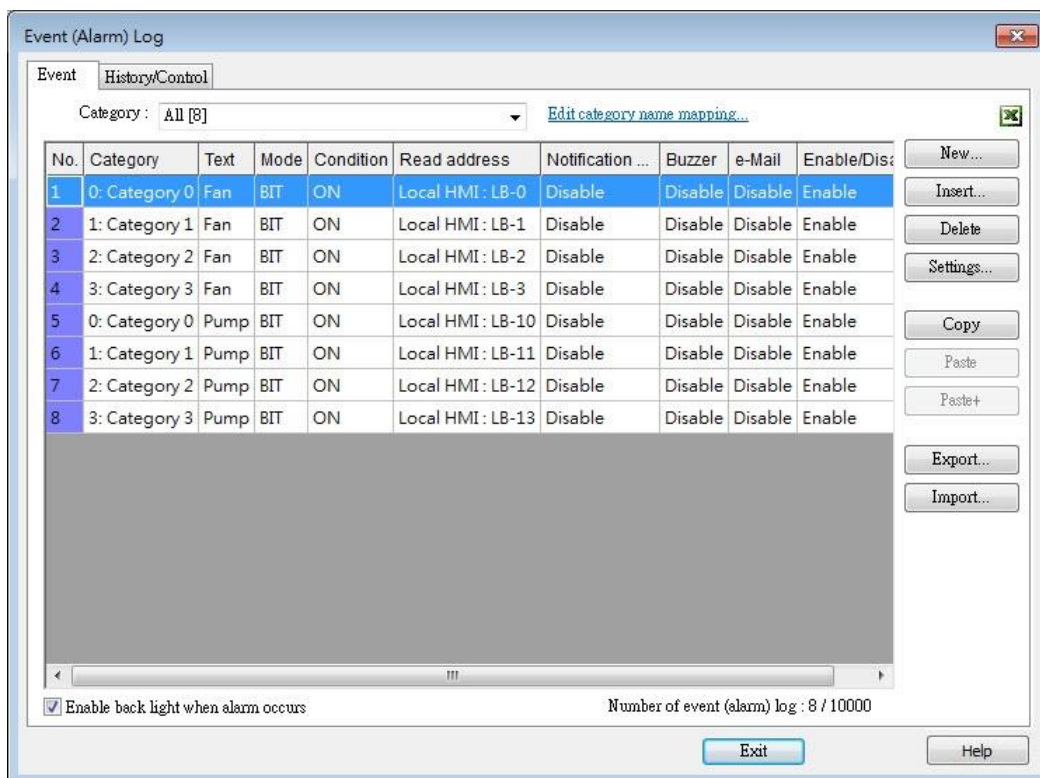

Setting

Description

Edit category name mapping

Event Bar Chart will show the name of each category.

13.51.2.2. General Tab

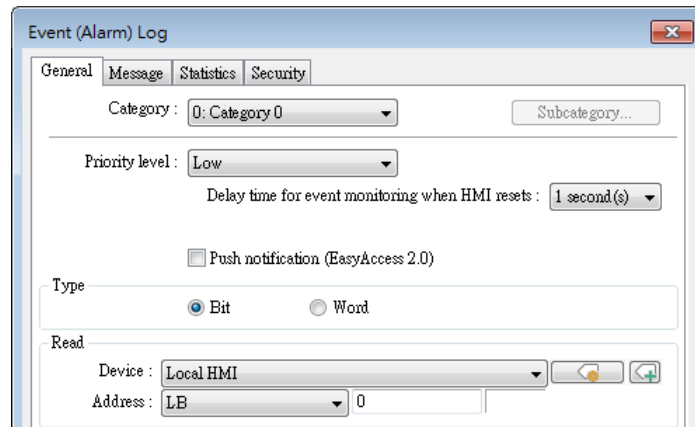

Setting

Description

Category

Event Bar Chart will illustrate the duration of all events in one category, please select correct category in this field.

13.51.2.3. Message Tab

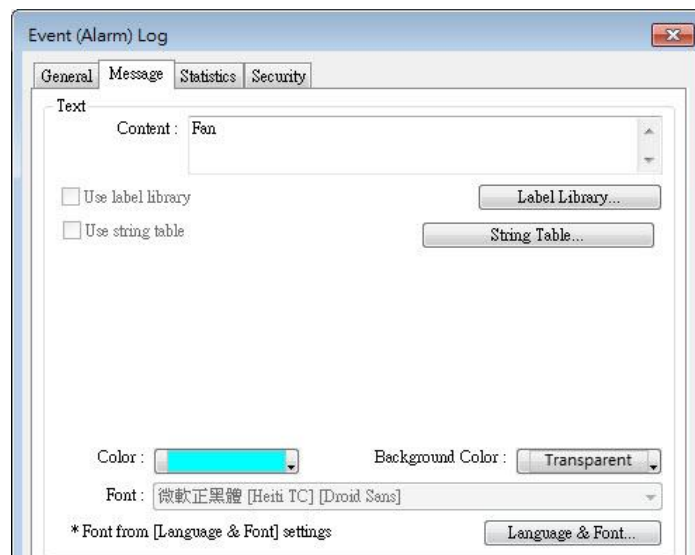

Setting

Description

Text

Enter the name of the event log.

Color

Select the color for the bar shown in Event Bar Chart that illustrates this event log.

13.51.2.4. Event Bar Chart



Click [Data/History] » [Event Bar Chart] in the menu to draw an Event Bar Chart.

General Tab

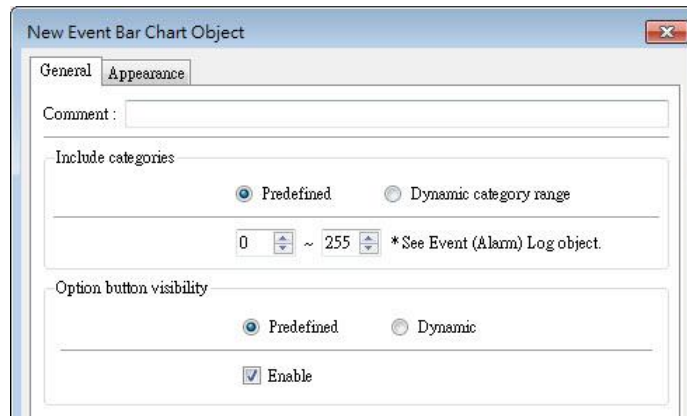

Setting

Description

Include categories

Predefined

Predefine a range of event categories to be displayed in the Event Bar Chart.

Dynamic category range

Use a set of consecutive addresses to select the display range of event categories dynamically.

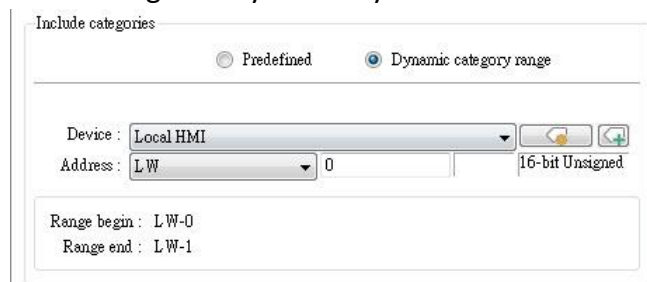

Option button visibility

Show or hide the option button  of the object.

Predefined

Select [Enable] to show the option button.

Dynamic

Choose a bit address to control option button visibility.

Option button visibility

Predefined Dynamic

Device : Local HMI

Address : LB 0

Appearance Tab

Setting

Description

Display timespan

Specify the time interval that is measured as a number of hours. Events occur during this time interval will be illustrated in Event Bar Chart. Tapping  in the upper right corner of the HMI screen can also change this setting.

Cancel	Option	Done
Begin Date and Time <input type="checkbox"/>		
End Date and Time <input type="checkbox"/>		
Event Filter		
Keyword		
Match case		<input checked="" type="checkbox"/>
Display Timespan (hr)		1 ▼

Style	By default 3 styles are provided for users to choose from.
Text size	Text sizes range from 50%~200%.
Title bar Format	Date + Time: 08/16/2018 13:55 ~ 08/16/2018 14:55 Date only: 09/03/2018 ~ 09/04/2018 Time only: 13:57 ~ 14:57
Watch line	A watch line shows at the point in the Event Bar Chart that is touched. The time represented by the touched point will show at the top of the watch line.
Number of Division	The number of divisions on X axis.
Time label	The format in which the time label is displayed.

HMI Settings

On cMT HMI or cMT Viewer, tap the  icon in the upper-right corner of the object to open the following settings window.

Cancel	Option	Done
Begin Date and Time <input type="checkbox"/>		
End Date and Time <input type="checkbox"/>		
Event Filter		
Keyword		
Match case		<input checked="" type="checkbox"/>
Display Timespan (hr)		1 ▼

Setting	Description
Begin Date and Time	Specify the begin date and time at which Event Bar Chart displays data. By default this setting is disabled, and Event Bar Chart displays from the begin date and time of the stored data.
End Date and Time	Specify the end date and time at which Event Bar Chart displays data. By default this setting is disabled, and Event Bar Chart ends at the end date and time of the stored data.
Event Filter	Keyword Events can be filtered by entering a keyword. Match case Use case-sensitive search when searching for events in English.
Display Timespan (hr.)	Dynamically change the time range (1~96 hours.) shown in Event Bar Chart. Select all to display all existing events.

 **Note**

- When HMI power is off, the HMI will not be able to obtain the alarm states; therefore, the alarm states during the power off period will not be illustrated in Event Bar Chart, not even after the power turns on.

13.52. Action Trigger

13.52.1. Overview

The Action Trigger object can trigger a sequence of action groups when the specified condition is met. Users can divide actions into action groups and the actions within the same group are executed at the same time when the specified condition is met. When all the actions within the same group are completed, the actions in the next group are then executed. This object is only available on cMT / cMT X Series models.

Action Trigger has two types, each with different modes for triggering action execution:

Action Trigger (per-page): [Window open/close], [Backlight on/off], and [Value changed] modes.

Action Trigger (Global): [Idle timeout], [Value changed], [Control token], [User secure access], and [Condition object] modes.

13.52.2. Configuration



Click [Object] » [Action-related] » [Action Trigger (per-page)] or [Action Trigger (Global)] icon on the toolbar to open an Action Trigger object property dialog box. Clicking [New] can add a new Action Trigger.

General Tab

Action Trigger (Per-page)

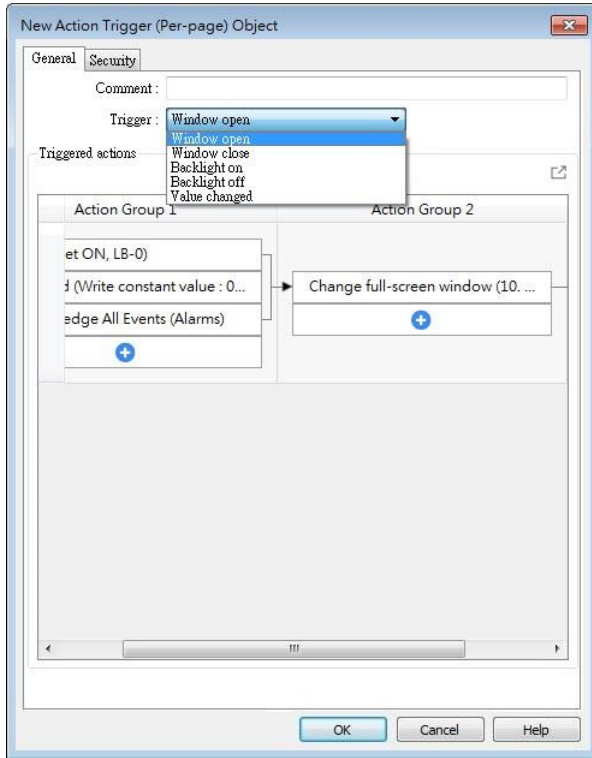

Action Trigger (Global)

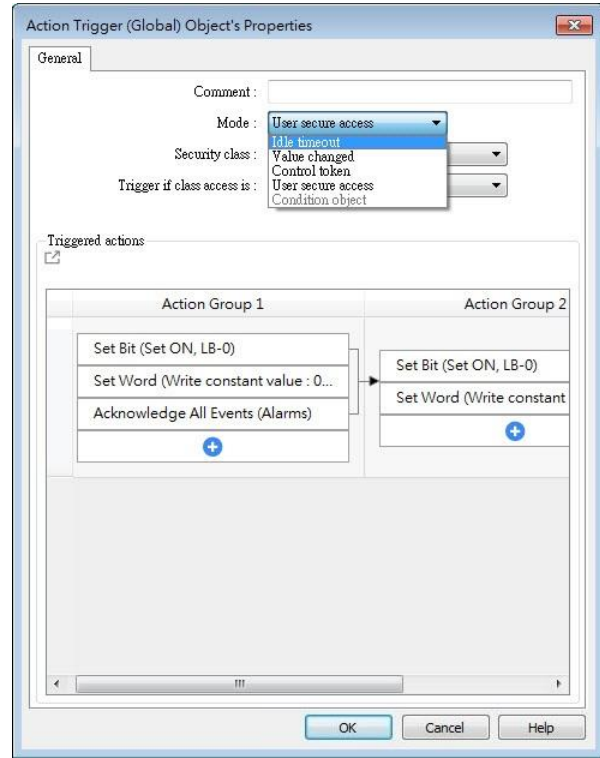

Setting	Description
Trigger (per-page)	<p>Window open: Triggers actions when window opens. Settings in Security tab will not be available when using this mode.</p> <p>Window close: Triggers actions when window closes.</p> <p>Backlight on: Triggers actions when backlight turns on.</p> <p>Backlight off: Triggers actions when backlight turns off.</p> <p>Value changed: When the state of the designated register meets the preset condition, Action Trigger will start executing.</p>
Mode: Idle Timeout (Global)	<p>If the screen is left untouched for more than the specified time limit configured in [Idle Timeout], Action Trigger will start executing. Range: 1~43200 seconds</p>
Mode: Value Changed (Global)	<p>When the state of the designated register meets the preset condition, Action Trigger will start executing.</p> <p>Check condition recursively when actions ended When all actions are completed, the trigger condition will be checked again; and if the condition is met, the actions will be triggered again.</p> <p>Dynamic condition value This option is available when [Word] is selected as Type. Selecting this option opens the [Read/Condition use different addresses]</p>

option. When [Read/Condition use different addresses] is not selected, the condition value is read from the next contiguous register of [Value address].

Control
Token

Triggers actions when the Control Token is acquired or unacquired.

(Global)

User Secure
Access

Triggers actions when access to the specified security class is obtained or lost. When the security class is [Any], the actions can be triggered, regardless of class, when the access is obtained or lost.

(Global)

Condition
Object

Triggers actions when the conditions set in Condition object are met.

(Global)
Check condition recursively when actions ended

When all actions are completed, the trigger condition will be checked again; and if the condition is met, the actions will be triggered again.

Action Group

Actions are classified into groups. Actions in the same group will simultaneously be triggered, and only after the actions in the previous group have been all triggered, the actions in the next group will then be triggered.

Delay

Delays the action for the specified time period (milliseconds).

Set Bit

Sets the designated bit address ON or OFF.

Set ON

Sets ON the designated bit.

Set OFF

Sets OFF the designated bit.

Toggle

Alternates the bit state.

Set Word

Changes the value in the designated word address.

Write constant value

Writes the constant value to the designated register.

Increment value (JOG+)

Increases value in register by a set amount in [Inc. value], up to the [Upper limit].

Decrement Value (JOG-)

Decreases value in register by a set amount in [Dec. value], down to the [Bottom limit].

Dynamic Limits (JOG+, JOG-)

Sets the [Upper limit](JOG+) and [Bottom limit](JOG-) by a designated register.

Write constant string

	<p>Writes the constant string to the designated register.</p> <p>Object Control Command (cMT / cMT X only)</p> <p>Listed for selection are commands (with their corresponding command values) available for the control address of various functions.</p> <p>System Tag Command (cMT / cMT X only)</p> <p>When a system tag is set as write address; for example, LW-9134: Language Mode, the commands relating to the system tag can be selected.</p>
Change window	<p>Switches to the designated window. Change full-screen window can only be the last action in the last group in an Action Trigger.</p> <p>Change full-screen window: Changes to another base window.</p> <p>Change common window: Changes common window.</p> <p>Return to previous window: Changes from current screen to the previous one displayed. For example, when window no. 10 is changed to window no. 20, this function can be used to return to window no. 10. This function is only available for base window.</p> <p>Animation Setting:</p> <p>The effects are: Fade, Fly, Float, Wipe, Split, Circle, Clock, Zoom, Turn, Push. Different effects may be used for Start (window appears) and End (window disappears).</p> <p>[Duration] specifies how many milliseconds (ms) a transition effect takes to complete.</p> <p>[Direction] The direction of the transition.</p>
Execute Macro	<p>Executes one of the Macros from the drop-down list that has already been configured by users. Running a macro may take a while to complete; therefore, when [Execute Macro] is put into an action group, it is seen as completed when it is triggered. The system will not wait for the macro to complete running before moving on to the next action group.</p>
Popup Window	<p>Pops-up a designated window.</p>
Close Window	<p>Closes currently opened window.</p>
Popup Calculator Window	<p>Opens a calculator with an unchangeable appearance, allowing operators to do simple calculation and enter the result to a destination object by pressing the Enter key.</p>
Keyboard	<p>Inputs characters/control signals, as often used with [Numeric] or</p>

Input	<p>[ASCII] objects.</p> <p>Enter: Same as the keyboard's "Enter" function.</p> <p>Backspace: Same as the keyboard's "Backspace" function.</p> <p>Clear: Clear the value in the word register.</p> <p>Esc: Same as the [Close window] function; it is used to close the keyboard window.</p> <p>Delete: Same as the keyboard's "Delete" function, deletes the number or character on the right side of the text cursor.</p> <p>Left: Same as the keyboard's "←" key moves the text cursor to the left side of the previous number or character.</p> <p>Right: Same as the keyboard's "→" key moves the text cursor to the left side of the next number or character.</p> <p>Inc: Add 1 to the current value.</p> <p>Dec: Minus 1 from the current value.</p> <p>ASCII/UNICODE: Specify the character to be entered by this key.</p>
Screen Hardcopy	Saves current screen as a hard copy file into a SD card or USB disk.
Acknowledge all events (Alarms)	Acknowledges all events at once.
Import Data	<p>Imports the e-mail contacts or user accounts, or logs in using USB Security Key.</p> <p>Data Position:</p> <p>The external device to read data from. Options: USB disk or SD card.</p> <p>Account import mode:</p> <p>If [Overwrite] is selected, there will be only imported accounts after import. If [Append] is selected, there will be imported accounts in addition to existing accounts after import.</p> <p>Delete file after importing user accounts:</p> <p>The system will delete the account data saved in the external device after importing; this can prevent the account data from leaking out.</p>
Wait Until	<p>The next group will be executed only when the condition set for a designated bit or word address is met. However, if the condition is not met even after the set wait time (timeout), it can either move on to the next action group or end prematurely without continuing.</p>
Data Transfer (Global)	Sends the value in the designated address to another address.
File Transfer	Transfer files by FTP. HMI will connect to the FTP server in passive

mode.

General Tab:

Download: Transfer file from FTP server to local HMI.

Upload: Transfer file from local HMI to FTP server.

Server address:

[Direct]: Designate server address related settings in EBPro.

[Dynamic]: Designate an address for changing the server address related settings dynamically on HMI.

Suppose the dynamic address is set to LW-n, then:

LW-n: Host usage (0: IP, 1: Domain name)

LW-n+1: IP (4 words)

LW-n+5: Port

LW-n+6: Authentication (0: None, 1: Account)

LW-n+7: Username (16 words)

LW-n+23: Password (16 words)

LW-n+39: Domain name (64 words)

Delete the source file after successful transfer

Following successful transfer, the source file will be deleted. When transferring in [Download (FTP -> HMI)] mode, please make sure that the account has the write permission on the FTP server.

File Tab:

Set file position and full path of FTP server / Local HMI. When a folder path is specified, all the files in that folder will be transferred, not including files in subfolders. When a file with identical file name already exists, it will be overwritten regardless.

Status Tab:

Designate an address for showing file transfer result and FTP server response. Please use the following link for more information on FTP server return codes.

https://en.wikipedia.org/wiki/List_of_FTP_server_return_codes

Control

The action to acquire or unacquire a Control Token.

Token

Control Token: Select a Control Token.

Action: Set this action to acquire or unacquire a Control Token.

Max. waiting time: Continues or stops running the next action group if the Control Token is still not acquired even after the set [Max. waiting time].

Backup

Backup historical data or recipe data to an external storage device, or transfer data via email or FTP server.

Safely**Remove USB
disk/SD card**

Safely remove the external storage device to ensure data integrity.

 **Note**

- At most 1000 Action Triggers can be created in a project.
- At most 20 groups can be created in an Action Trigger, and at most 20 actions can be added into a group.
- To rename an action group, right-click on the name of the action group and select [Rename].
- File Transfer Error Codes:

Error Code	Description
0	File transferred successfully.
1	The HMI directory for download does not exist.
3	USB disk or SD card is not found.
4	HMI or FTP directory is empty.
5	Uploaded file does not exist.
8	Operation rejected by FTP server.
9	USB disk or SD card is full.
10	Unknown error.

13.53. Calendar

13.53.1. Overview

The Calendar object can show a calendar on cMT / cMT X Series HMI.

13.53.2. Configuration



Click [Object] » [Time-related] » [Calendar] icon on the toolbar to open a Calendar object property dialog box. Set up the properties, press OK button, and a new Calendar object will be created.

General Tab

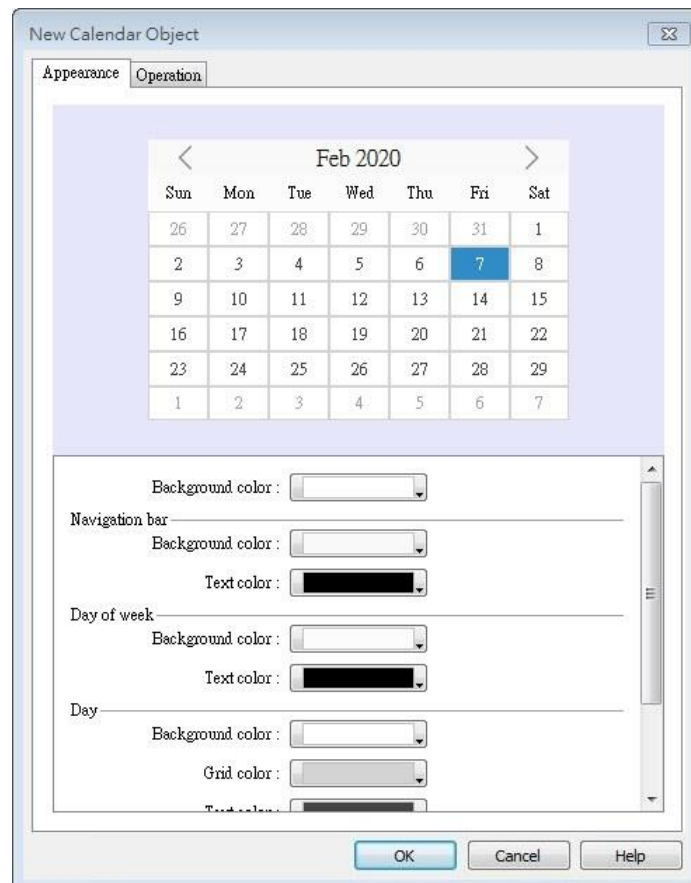

Setting

Description

Appearance

Navigation bar Set the background color and text color of the navigation bar.

Day of week Set the background color and text color of the days of

week.

Day Set the background color, grid color, and text color of the days.

Today Set the background color and text color to show today.

Operation

Output the date information in a number or a string to the designated address.

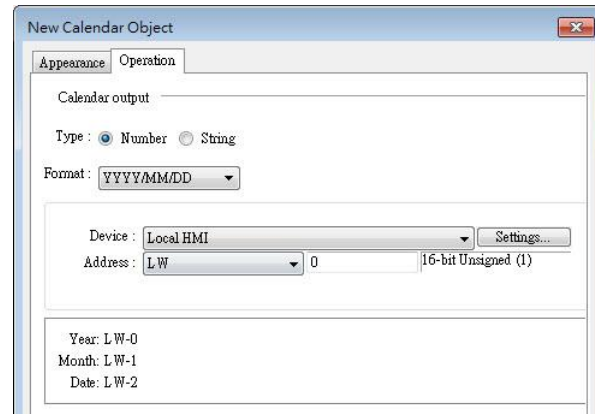

13.54. Touch Gesture

13.54.1. Overview

For some time, smartphones or tablets nowadays have been using gesture-based operation, e.g., pinch with five fingers to close an app. Now, with HMI having Touch Gesture object that supports up to 23 touch gestures, HMI can provide operating experience comparable to that of a smartphone or tablet.

The Touch Gesture finger limit is 5.

13.54.2. Configuration



Click [Object] » [Action Related] » [Touch Gesture] icon on the toolbar to open the Touch Gesture property dialog box. Select a window and then add its allowable touch gestures.

General Tab

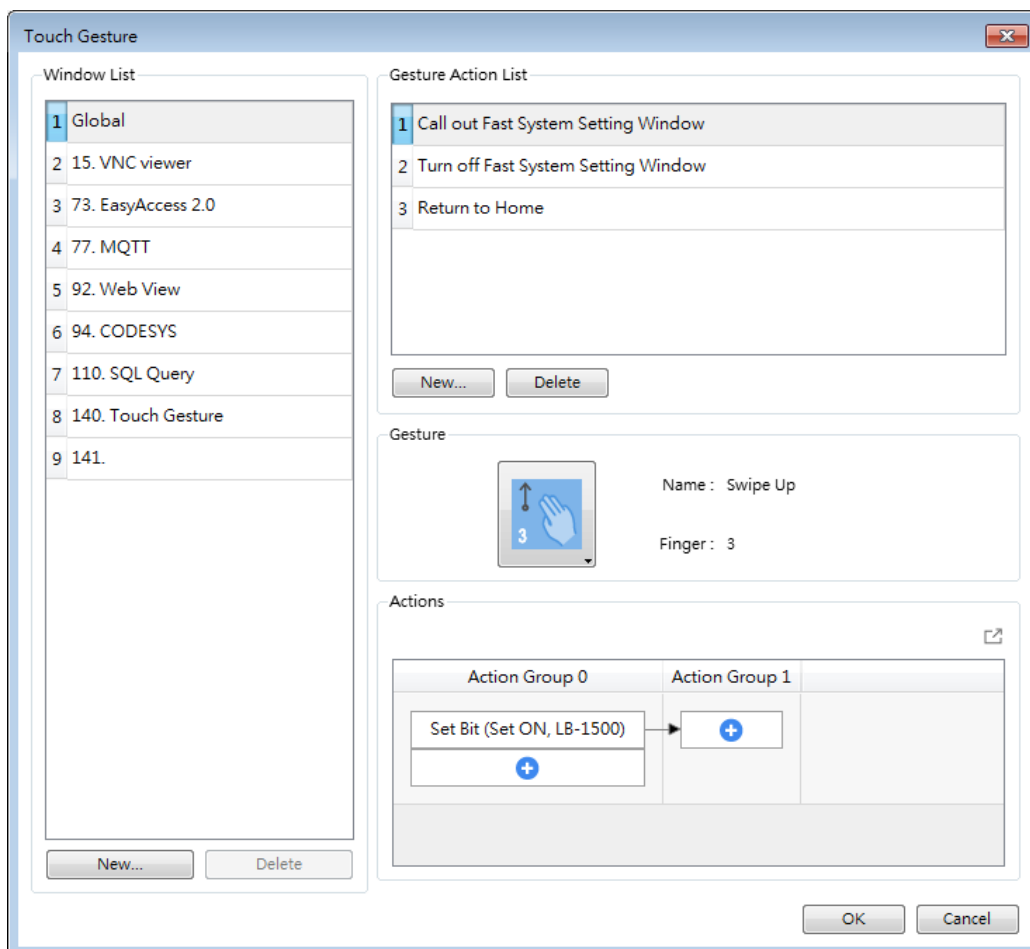

Setting	Description
Window List	Allow the gesture actions to be used in a specific window or all windows. When Global is selected, one-finger gestures are not supported. Add/Delete Add or delete a window that allows this gesture action.
Gesture Action List	Shows gesture action list for the window. Add/Delete Add or delete a gesture action.
Actions	Set an action or group of actions triggered using this gesture. For more information on the actions, see Chapter 13.36 or 13.52 in this manual.

 **Note**

- Up to 16 gestures can be used for each window setting (global/individual).
- When the same gesture is used in both the Global window and an individual window, the gesture is effective only for the individual window.
- When a user performs a gesture on the screen, objects are still triggered when they are touched.
- The touch gesture for an individual window is only effective when the window is a base window. If the said window is a pop-up window, or overlaid windows, its touch gesture will be ineffective and its gesture actions will not be executed.
- Detection for the next gesture will only start when the actions for the current gesture have been completed.

13.55. PLC Web Browser

13.55.1. Overview

The PLC Web Browser object allows browsing of PLC web pages. This feature is currently supported only on the cMT X Advanced series. For a detailed list of supported models, see [Appendix A: Comparison of HMI Software Features](#).

13.55.2. Configuration



Click [Object] » [Media] » [PLC Web Browser] icon on the toolbar to open a PLC Web Browser object property dialog box. Set up the properties, press OK button, and a new PLC Web Browser object will be created.

General Tab

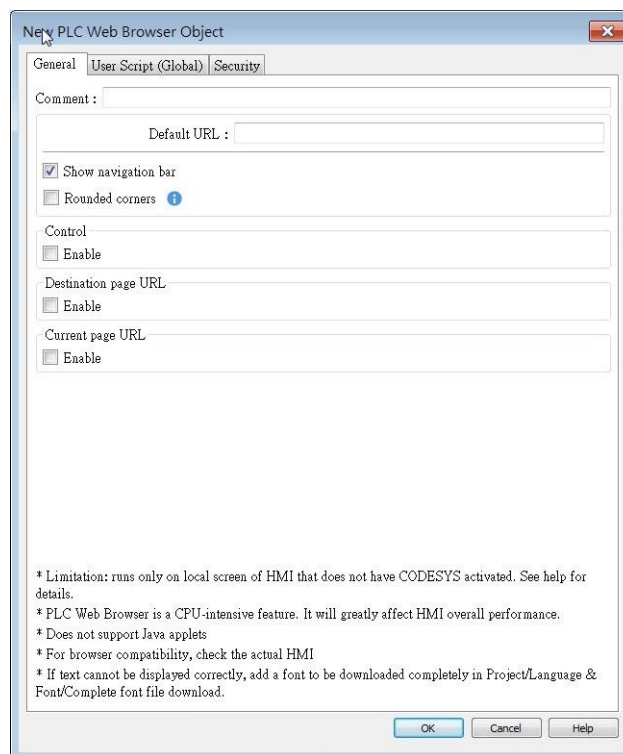

Setting	Description
Default URL	Enter the URL into the provided field.
Show navigation	With this option selected, users can directly change URL, refresh page, or zoom in/out web page by clicking the icons in the navigation

bar

bar displayed on HMI.

Icon	Command
←	Go back to the previous page
→	Go forward to the next page
🔍	Zoom out the page
🔍	Zoom in the page
🏠	Return to homepage
🔄	Refresh the page

Rounded corners

With this option selected, the browser window will be displayed with rounded corners.

Control address

LW-n: Command ID

Value	Command
0	None
1	Go destination
2	Reload
3	Stop
4	Go back
5	Go forward
6	Clear cache
7	Clear cookie

LW-n+1 Status

Value	Command
0	Load started
1	Load stopped
2	Load succeeded
3	Load failed

LW-n+2 Error Code

Value	Command
0	No error
1	Internal error
2	Connection error
3	Certificate error
4	HTTP error
5	FTP error
6	DNS error

Destination page URL

The designated register is for entering a URL with length limit 255 words. After entering the URL, please enter value 1 in the Command

address	ID address to go to the destination page.
Current page URL address	Shows the URL of current page, the length limit is 255 words.

User Script (Global)

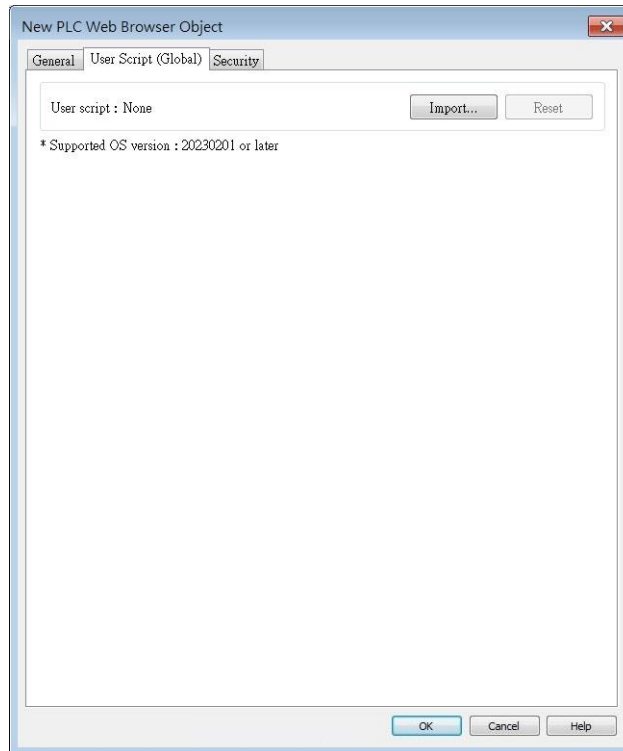

PLC Web Browser's User Script settings allow users to import a JavaScript file, which can be used to modify the webpage code. This User Script JS file is shared globally within the project, meaning it will have the same effect on all the PLC Web Browsers in the project.

This feature requires OS version 20230201 or later.

13.55.3. Notes on PLC Web Browser

- 1 For more details about supported models and OS versions, please see Appendix A in this user manual.
- 2 PLC Web Browser object is designed specifically for connection to PLC's built-in web server, allowing users to access PLC web page to configure PLC and view PLC data. Using PLC Web Browser to connect to other types of websites may lead to unexpected results or errors.
- 3 Displaying relatively complex web page using PLC Web Browser will occupy more memory and consume a large amount of CPU, which can significantly slow down HMI's operating speed. Users are advised to use change page function or a Direct/Indirect window to display PLC Web Browser object only when it is needed, in order to prevent reduction of system performance.
- 4 As HMI memory is limited, when the PLC Web Browser occupies too much memory, the

system will automatically stop PLC Web Browser to ensure proper operation of HMI.

- 5 In consideration of performance, PLC Web Browser can only run on an HMI whose CODESYS is not activated.
- 6 Due to rapid change in web technologies, it is not guaranteed that all PLC web servers are supported by PLC Web Browser in EasyBuilder Pro, and certain PLC web pages may not be correctly displayed using PLC Web Browser.
- 7 When multiple PLC Web Browser objects are placed in a single window, only one of them will run while the rest remain ineffective.
- 8 PLC Web Browser object displays web page on top of everything else even if there are other objects placed above it.
- 9 When the PLC Web Browser is clicked or tapped in cMT Viewer running on a PC, smart phone or tablet device, the default browser for the device will be used to open the web page. Note that, in this case, to access the PLC within the same network as HMI, the device running cMT Viewer should also be in the same network as the PLC.
- 10 Browsing web pages using PLC Web Browser on cMT-iV5/cMT-iV6 is not possible.
- 11 Features not supported by PLC Web Browser:
 - Saving files using “Save As”
 - Text selection
 - Right-click menu
 - Drag-and-Drop
 - Windows prompt for username and password input (e.g., FTP login)
 - Video playback (e.g., YouTube)
 - File upload/download
 - Webpages developed using Java
- 12 If the text on a webpage is not displayed correctly in the PLC Web Browser, please refer to Chapter 15.5.5 in this user manual for information on how to download the complete font file to add support for non-built-in fonts in the OS to the PLC Web Browser.

13.56. Condition

13.56.1. Overview

The Condition object can be used to replace the if-else statement in macro. When the specified conditions in the Condition object are met, the designated output bit address will be set ON. The output bit address can be used in objects' security settings, Event Log, Backup, and Data Transfer...etc. The Condition object can be selected in Action Trigger (Global) object's mode setting. Note that this object is available only on cMT / cMT X models.

13.56.2. Configuration

if

Click [Object] » [Condition] icon on the toolbar to open a Condition object property dialog box. Click [New] to add a new condition, and then click [OK] to create a Condition object.

General Tab

The screenshot shows the 'New Condition' dialog box with the following configuration:

- Name:** Condition 1
- Conditionals Table:**

Name	Description	Options
1 Conditional 1	Value address : [Local HMI : LB-0] is "ON"	Insert
2 Conditional 2	Value address : [Local HMI : LW-0] > "0"	Insert
3 Conditional 3	Value address : [Local HMI : LW-1] > "100"	Insert

- Logical expression:** AND
- Output:** Output
- Device:** Local HMI
- Address:** LB 10

Buttons: New.., Delete, Settings..., OK, Cancel, Help

Setting	Description
Name	Enter the name of this object.
Conditionals	Set trigger conditions.
Type	Value Address: Select an address type from Bit / Word.

Condition Object: Select another Condition object.

Logical expression

AND: The Condition object is effective when all the specified conditions are met.

OR: The Condition object is effective when one of the specified conditions is met.

Customized: Customize logical expressions involving combinations of AND, OR, and () parentheses. The trigger condition is determined based on the evaluation of the logical expression.

Output

With this option selected, when the conditions are met, the specified bit address will be set ON. When the conditions are not met, the specified bit address will be set OFF.

Note

- At most 128 Condition objects can be created in a project.
- At most 8 conditions can be created in a Condition object.

Example 1

Here is an example of using Condition object to replace the if-else statement in macro. The macro below contains three conditions.

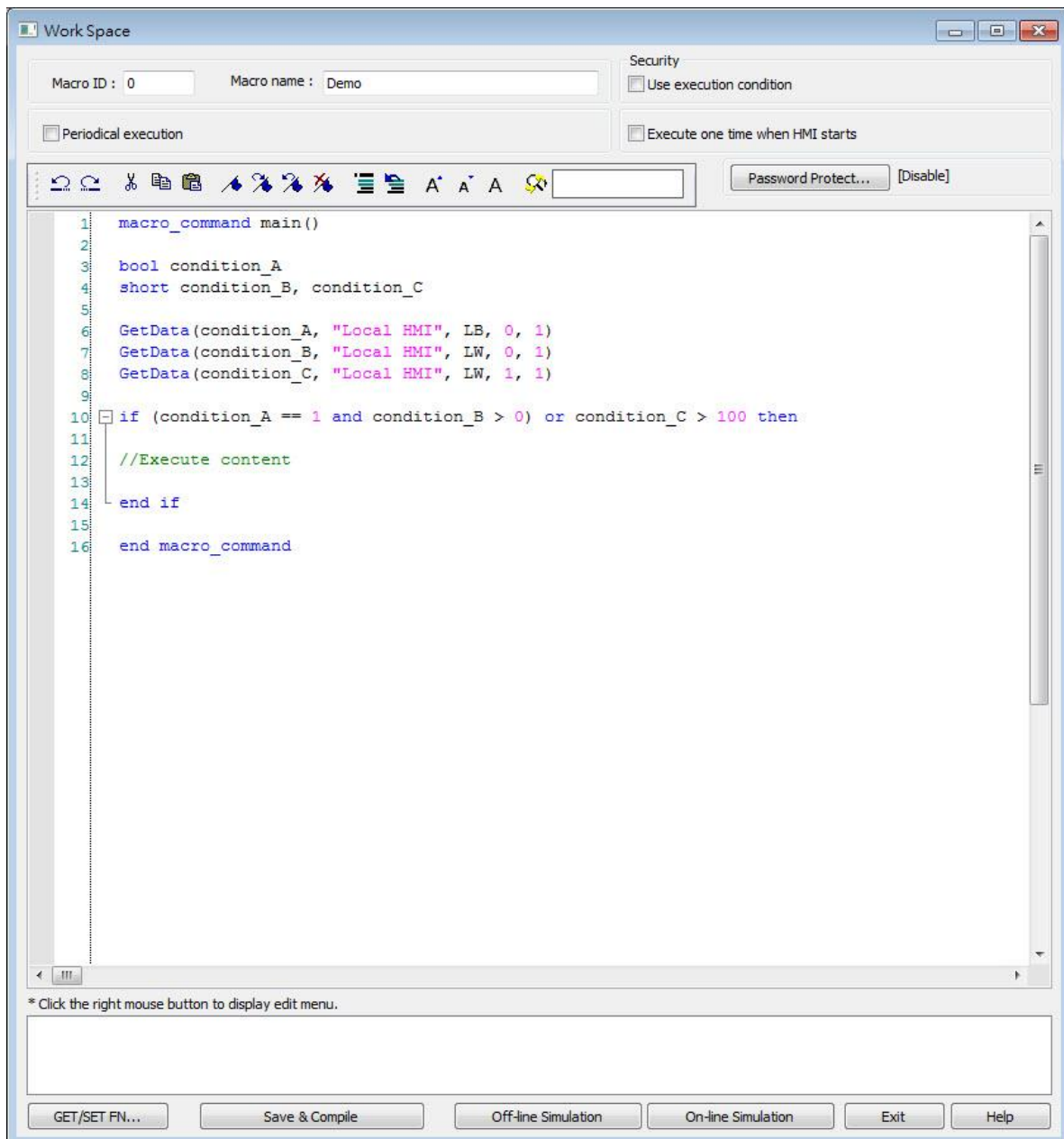

1. Create a Condition object, add condition_A, condition_B, condition_C and then customize a logical expression “({1} AND {2}) OR {3}” as shown below.

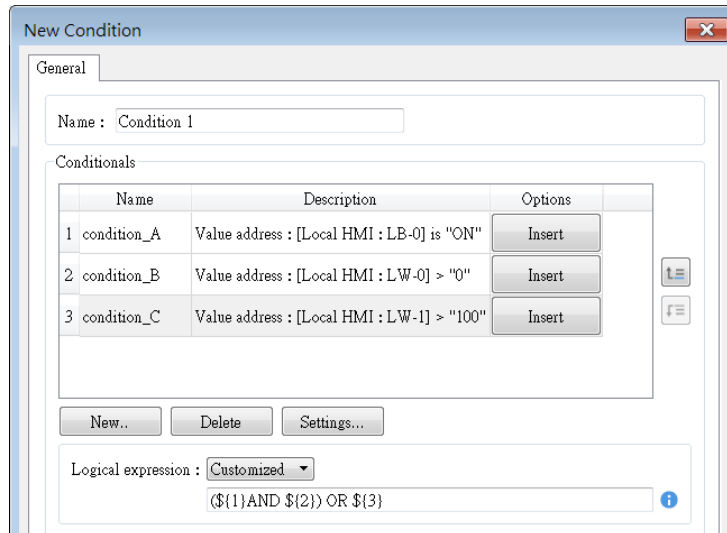

2. Now the Condition objects can do the same thing as the macro, which triggers actions according to the conditions.

13.57. FTP Connection

13.57.1. Overview

FTP connection settings can be configured to enable transfer of backup files (screen hardcopies or historical data) between the HMI and a PC via FTP server, providing a similar experience to using EasyPrinter. This feature is supported only on cMT/cMT X Series models.

13.57.2. Configuration



Click the FTP Connection icon in Data/History tab to open the property dialog box. Set up the properties to add a new FTP connection.

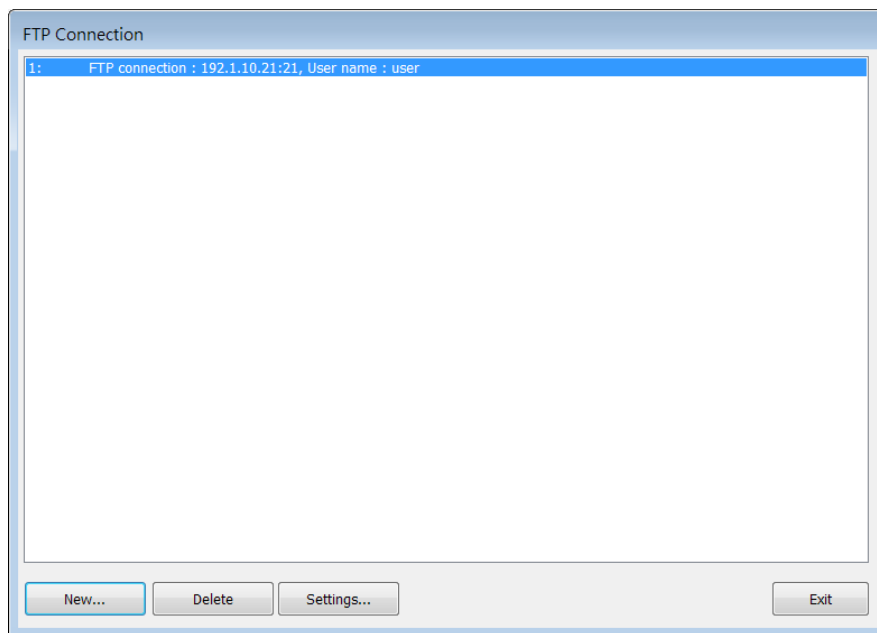

General Tab

FTP Connection's Properties

General

Server

Comment :

Server address

Direct Dynamic

Type : Plain FTP

Host : 192 . 168 . 1 . 10 Use domain name

Port : 21

Username : user Use anonymous

Password : ●●●●●●●●●●

OK Cancel Help

Setting

Description

Server address

Direct

Use the server address related settings (e.g. Type, IP, Port...etc.) in EasyBuilder Pro.

Dynamic

Specify an address for setting FTP connection parameters dynamically on HMI.

Server

Comment :

Server address

Direct Dynamic

Device : Local HMI

Address : LW

Enable secure FTP connection

Host usage : LW-0
(0 : IP, 1 : Domain name)
IP : LW-1 (4 words)
Port : LW-5
Authentication : LW-6
(0 : none, 1 : account)
Username : LW-7 (16 words)
Password : LW-23 (16 words)
Domain name : LW-39 (64 words)

Type	<p>Plain FTP No encryption.</p> <p>Implicit FTP over TLS The entire connection is encrypted. Default TCP port is 990.</p> <p>Explicit FTP over TLS Encryption begins following authentication request (AUTH TLS). Default TCP port is 21.</p>
Host	FTP server's IP address or domain name.
Port	FTP server's port number.
Username	FTP server's username.
Password	FTP server's password.

 **Note**

- If “This server is used and cannot be deleted.” message shows while deleting an FTP connection, please disable FTP function in [Home] » [System Parameters] » [FTP] tab.

13.58. Date/Time

13.58.1. Overview

The Date/Time object displays the current date and time in the specified format and font.

13.58.2. Configuration



Click the Date/Time icon on the toolbar or click [Object] » [Time-related] » [Date/Time] in the menu to create a Date/Time object.

General Tab

The dialog box 'New Date/Time Object' has three tabs: General, Security, and Shape. The General tab is active and contains the following settings:

- Date:**
 - Enable
 - Format: MM/DD/YY
- Day of week:**
 - Enable
 - Label: Settings...
- Time:**
 - Enable
 - Format: HH:MM:SS
 - 12-hour clock
 - Label (AM/PM): Settings... [am], [pm]
 - Right align
- Font:**
 - Name: Arial [Arial] [Droid Sans]
 - Color: [Black]
 - Size: 15
 - Align: Center

Buttons: OK, Cancel, Help

Setting	Description
Date	Set the date format.
Day of week	Set the label of the days of the week.

Time	Set the time format.
Font	Set the font, color, size and alignment of the text displayed.

13.59. Template

13.59.1. Template Window

13.59.1.1. Overview

The Template Window object can be used to specify the source window for the Template object.

13.59.1.2. Configuration



Click on the [Object] » [Template] » [Template Window] icon on the toolbar to open the settings dialog box. Then click [Add], specify the template window range, and press the OK button. A new Template object will be created.

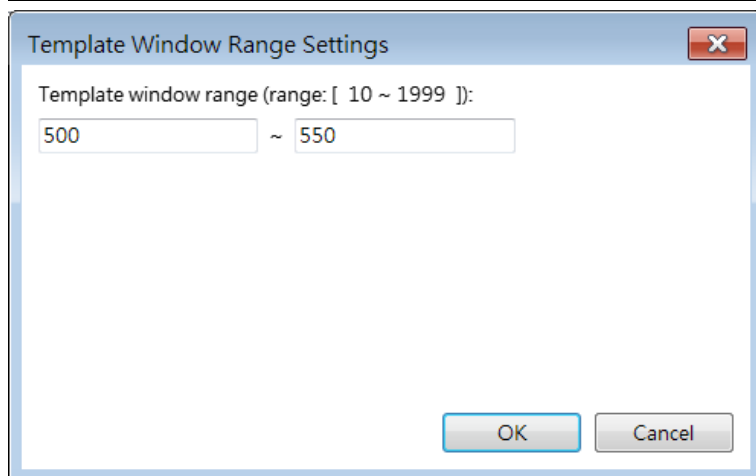
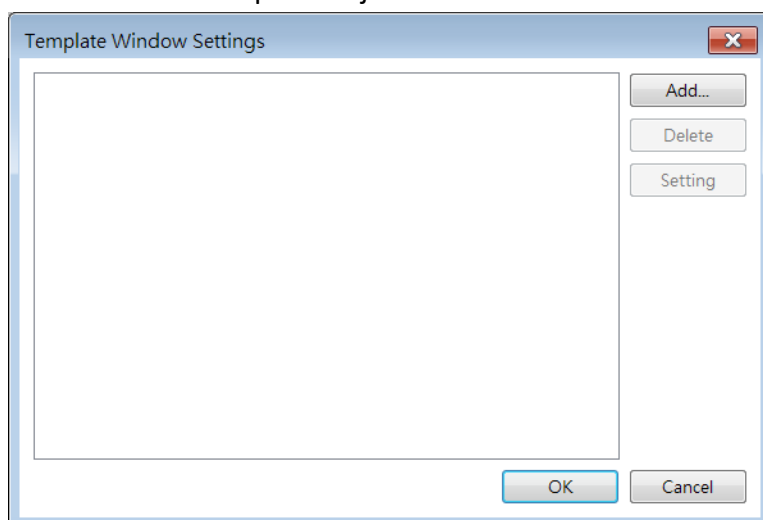

13.59.2. Template

13.59.2.1. Overview

The Template object reduces repetitive project design steps by replacing object addresses or texts based on Template Window settings.

13.59.2.2. Configuration

General Tab

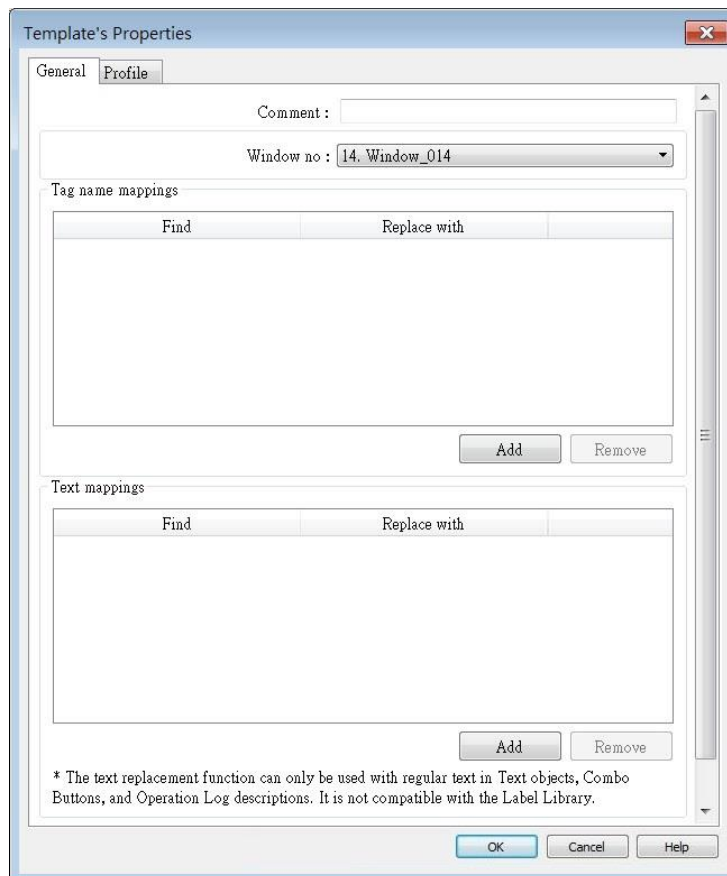

Setting	Description
Comment	User-defined object description.
Window no.	Select the source template window.
Tag name mappings	Find a custom string in the tag name and replace it with another custom string.
Text mappings	Find a custom string in the text label of a Text object, Combo Button, or Operation Log, and replace it with another custom string.

Note

- Tag name replacement is only supported for user-defined tags and tags using Symbolic

Addressing.

- Bulk replacement of tag names on multiple devices is supported. For instance, tag A can be replaced with tag B on device 1, while simultaneously replacing tag C with tag D on device 2. However, it's important to note that each replacement action is limited to tags within the same device.
- Text mapping is not supported for objects using Label Tag Library.
- Template objects are only effective during the editing phase and will be transformed into independent objects after compilation. This means that when decompiling .exob/.cxob files, the resulting project file will only contain independent objects, not template objects.
- The Template Window cannot contain Template objects.
- Template objects become independent only after compilation; therefore, Address Viewer and Label Tag Library cannot display their status after address replacement.
- Objects that extend beyond the Template Window's range, including those that go beyond the range after text replacement, will be removed and not displayed by the Template objects.

Example

Here is an example that demonstrates how to create a template:

1. Create two tags in Address Tag Library and name them Tag_0 and Tag_1.

Tag_0	Local HMI	LW-0	Word
Tag_1	Local HMI	LW-1	Word

2. Create a new window and set its size which will determine the size of the Template object.

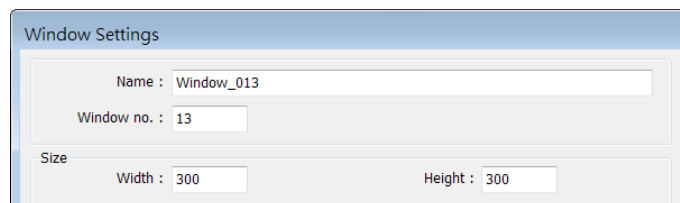

3. In the window created in step 2, place a Meter object and a Combo Button object, and set their read/write addresses to the Tag_0 created in step 1.

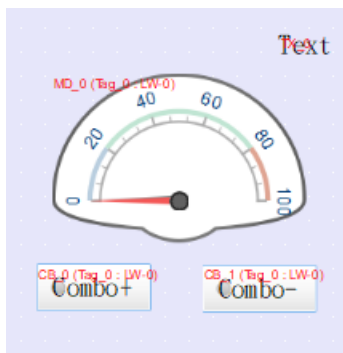

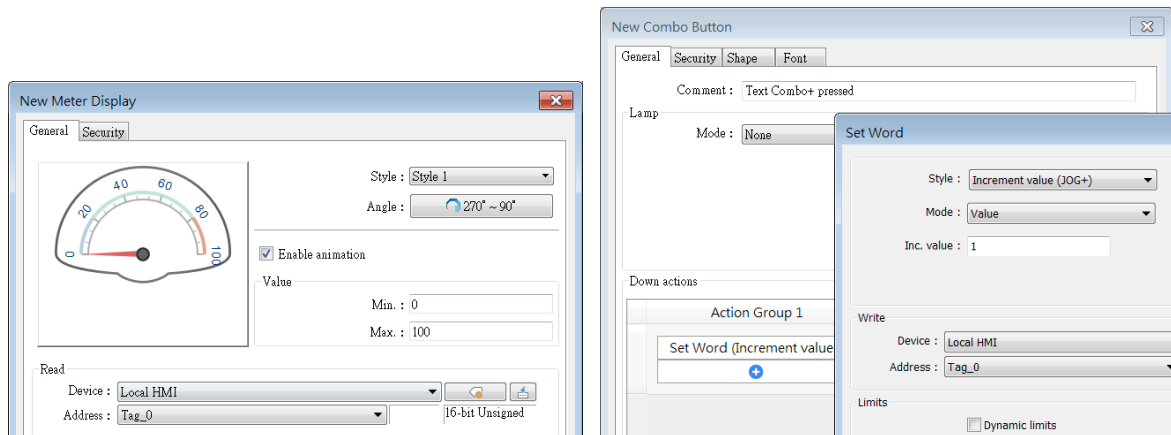

4. Set the Combo Button's comment to "Text Combo+ pressed" and its text label to "Combo+".

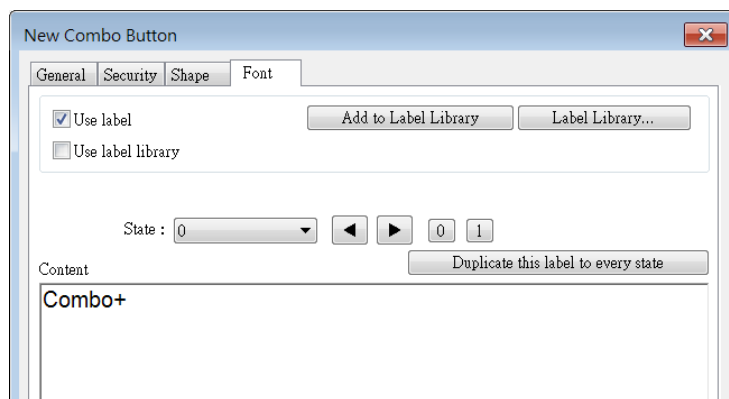

5. Place a Text object in the window created in step 2, and set its content to "Text".

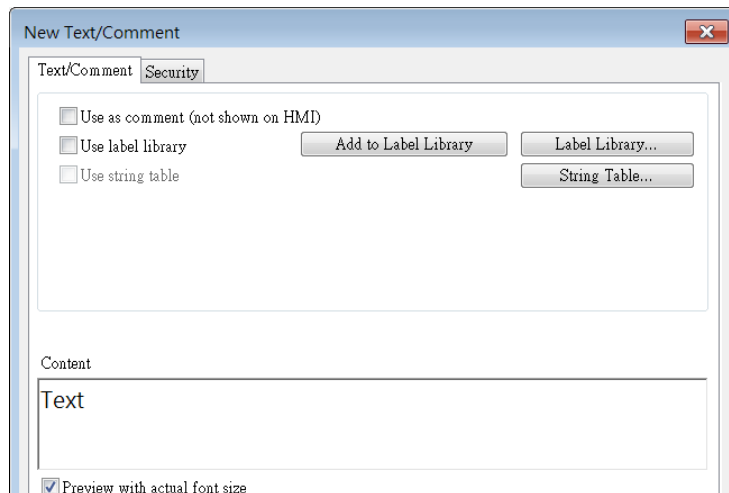

6. Set the window created in step 2 as the Template Window.

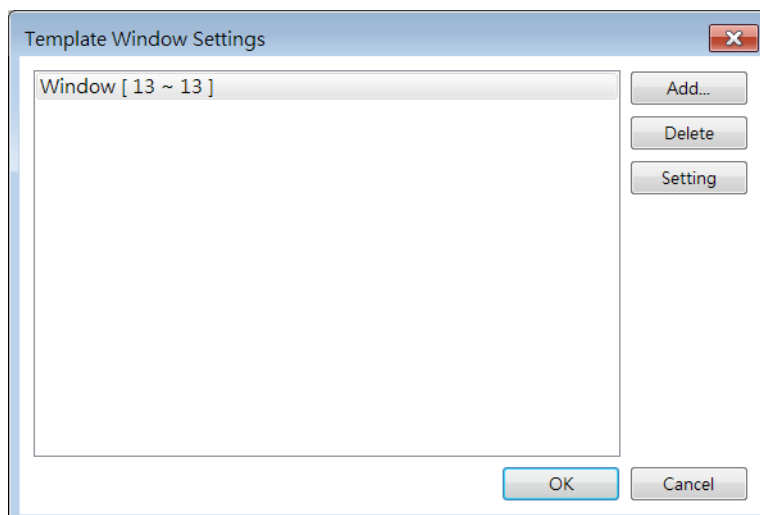

7. Create a Template object and configure it with the following settings.

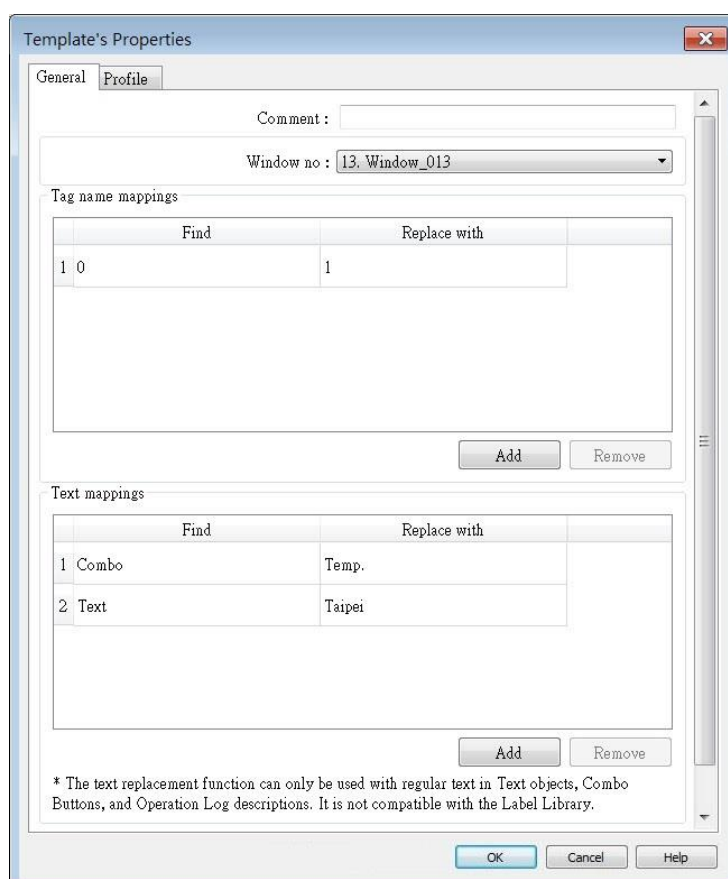

8. After compiling the project, EasyBuilder Pro will replace any tag names containing “0” with “1” for objects in the Template Window that use them. This means that “Tab_0” will be replaced by “Tag_1”. The text mapping feature will also replace object comments, text contents, and text labels according to the settings defined in the Template object.

