

# TOSHIBA INVERTER VF

Supported Series: Toshiba Invertor Protocol (ASCII code).

## HMI Setting:

Parameters	Recommended	Options	Notes
<b>PLC type</b>	TOSHIBA INVERTER VF		
<b>PLC I/F</b>	RS485 2W	RS422, RS485	
<b>Baud rate</b>	9600	9600, 19200	
<b>Data bits</b>	8	7 or 8	
<b>Parity</b>	Even	Even, Odd, None	
<b>Stop bits</b>	1	1 or 2	
<b>PLC sta. no.</b>	0	0-99	

<b>Online simulator</b>	YES	<b>Extend address mode</b>	YES
<b>Broadcast command</b>	YES		

## Device Address:

Bit/Word	Device type	Format	Range	Memo
B	Cmd. No B	HHHHdd	0 ~ 270f15	
W	Cmd. No	HHHH	0 ~ ffff	Parameters and data memory

## Wiring Diagram:

Note:

Before connecting with TOSHIBA INVERTER VF, make sure the SW1 of both sides are in the correct position. (SW1: wiring method selector switch)

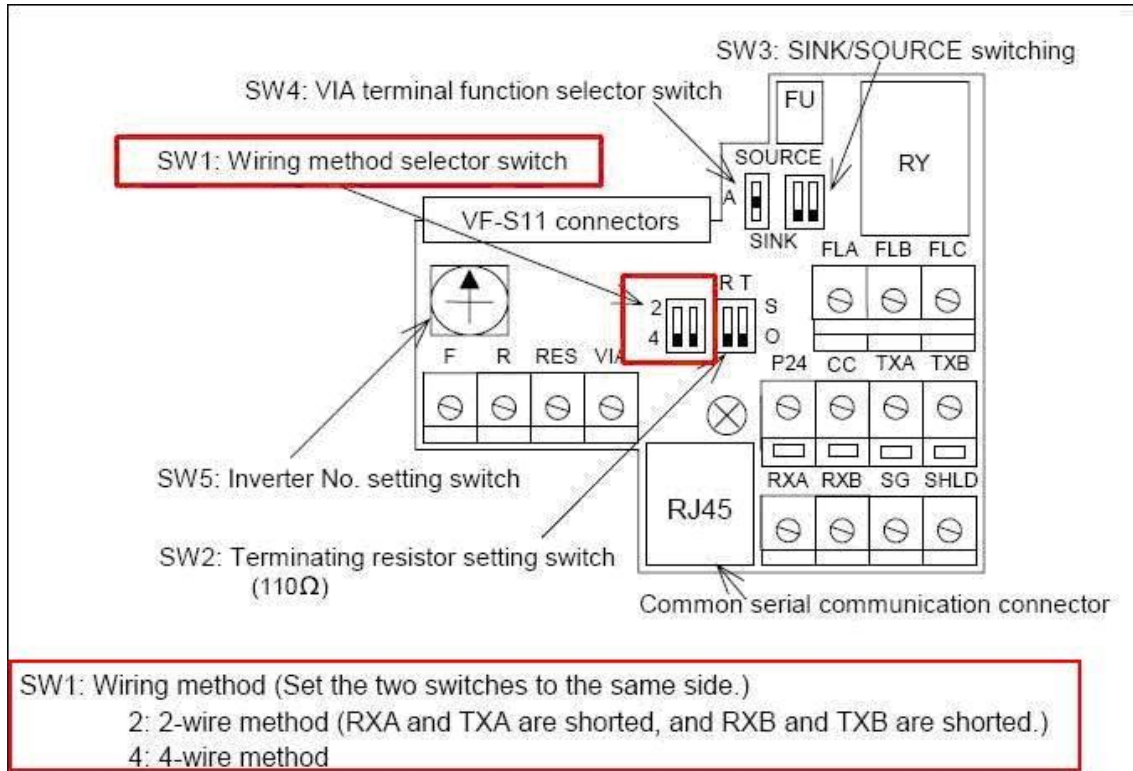

### Diagram 1

#### RS-485 2W

The serial port pin assignments may vary between HMI models, please click the following link for more information.

