

1 Installation and Startup Guide

This document covers the installation of iR-PU01-P, for the detailed specifications and operation, please refer to Datasheet, Brochure and Remote I/O User Manual. Please read all warnings, precautions, and instructions on the device carefully before use.

Install Environment:

Electrical Environment	The product has been tested to conform to European CE requirements. This means that the circuitry is designed to resist the effects of electrical noise. This does not guarantee noise immunity in severe cases. Proper wire routing and grounding will insure proper operation.
Environmental Considerations	<ol style="list-style-type: none"> (1) Make sure that the units are installed correctly and that the operating limits are followed. (2) Avoid installing units in environments where severe mechanical vibration or shocks are present. (3) Do not operate the unit in areas subject to explosion hazards due to flammable gases, vapors or dusts, or where acid gas, such as SO₂ exists. (4) For use in Pollution Degree 2 Environment and dry location. (5) Relative Humidity: 10% ~ 90% (non-condensing)
Operating Altitude (Atmospheric Pressure)	Below 3,000 m (9842.52 ft.), atmospheric pressure is 70.1 kPa.
IP rating	IP 20
Cleaning Considerations	Clean the device using dry cloths. Do not use liquid or spray detergents for cleaning.
 Warning	Protection impairment if used in a manner not specified by the manufacturer. Déficit de protection si utilisé d'une manière non spécifiée par le fabricant.

2 Unpacking the Unit

Unpack and check the delivery. If damage is found, please contact the supplier.

NOTE: Place the unit on a stable surface during installation. Dropping it or letting it fall may cause damage.

The package includes:

- (1) Installation Instruction, 2-sided A4 *1 (2) iR-PU01-P *1 (3) Connector *1 (4) Clips *2

3 Installation Instructions

Clip assembly: Insert one side of the clip into the hole on the case. Press down firmly in the direction shown in the figure on the right until hearing the clip snap into the case.

Clip removal: Insert a flathead screwdriver into the gap on the clip and then lift up the screwdriver. Placing a finger on the clip when lifting the screwdriver can prevent the clip from jumping away. The clip can also be removed directly by hand.

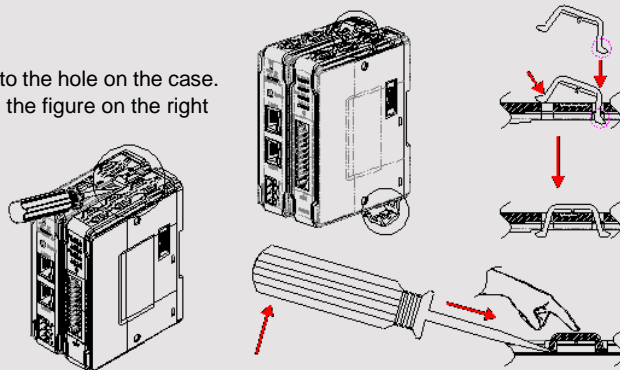

Rail mounting: DIN rail 35mm.

Panel mounting: Use two M4 or #8 panhead screws, mounting hole size is 4.6mm

Plan for adequate space around the unit and inside the enclosure, for ventilation and cables. Consider the heat from other devices inside the enclosure. The ambient temperature around the unit must be 0 ~ 55°C

NOTE: Please do not touch any of the connectors when the unit is powered up and running.

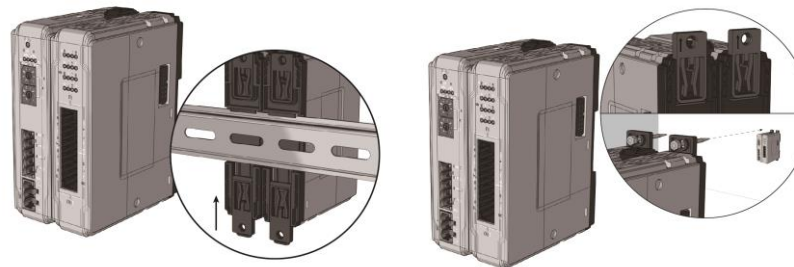

4 Connector and Wiring



Connector Specifications:

Wire AWG: 28~16

Operating Temperature: -40°C ~+115°C

Wire Strip Length: 7~8 mm

Spécifications du connecteur:

AWG de fil: 28~16

Température de fonctionnement : -40 °C ~+115 °C

Longueur de fil dénudé : 7~8 mm

NOTE: Please note that connecting a terminal device with resistance less than 10Ω to the digital output of iR-PU01-P may result in damage to iR-PU01-P.

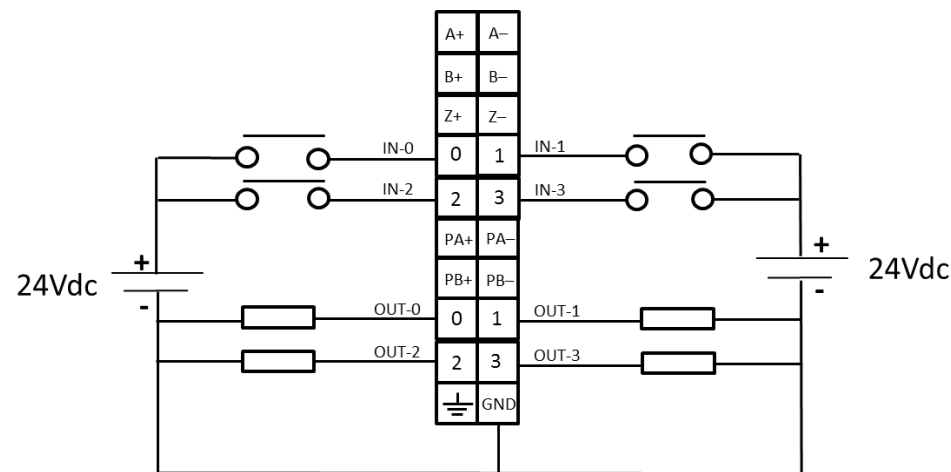

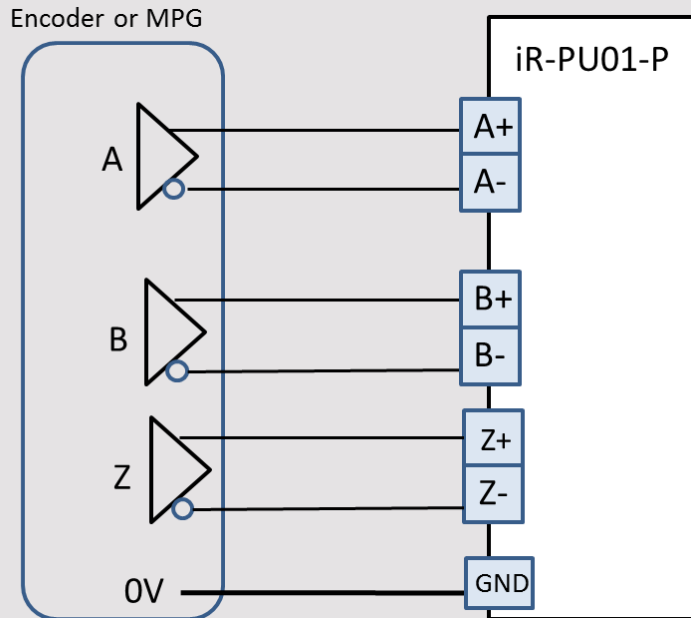
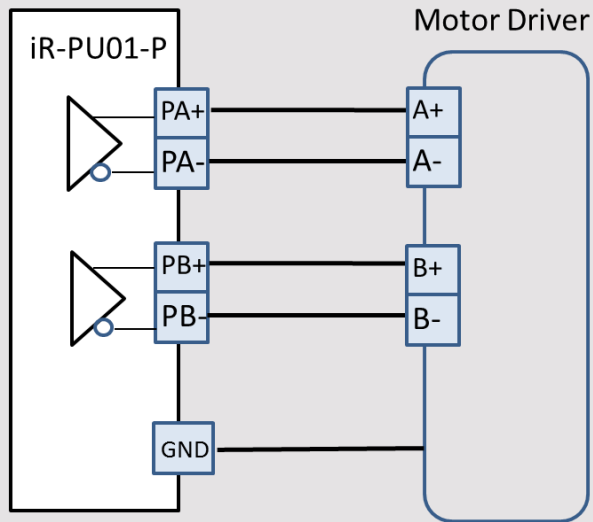

CAUTION

NOTE: Make sure that all local and national electrical standards are met when installing the unit. Contact your local authorities to determine which codes apply.

! Input Module

Please keep a distance between DC input signal line and AC power line in order to avoid noise.

! Digital Output

The allowable range of digital output voltage is 24 VDC (-15%/+20%). The maximum output current for each node is 50mA. The output short circuit protection implemented for the device can protect the device from overload conditions. The unit will be disconnected from the load when overload condition occurs, and will recover after power on the unit again.

! Emergency Stop

A Hard-wired EMERGENCY STOP should be fitted in any system using the product.

DANGER

! Hardware Considerations

The system designer should be aware that devices in Controller systems could fail and thereby create an unsafe condition. Furthermore, electrical interference in an operator interface can lead to equipment start-up, which could result in property damage and/or physical injury to the operator.

If you use any programmable control systems that require an operator, be aware that this potential safety hazard exists and take appropriate precautions. Although the specific design steps depend on your particular application, the following precautions generally apply to installation of solid-state programmable control devices, and conform to the guidelines for installation of Controllers recommended Control Standards.

! Programming Considerations

Checks should be placed in the controller to ensure that all writable registers that control critical parts of plant or machinery have limit checks built into the program, with an out-of-limit safe shut down procedure to ensure safety of personnel.

GMERU1P00_iR-PU01-P_Installation_20240627

Limited Warranty

This product is limited warranted against defects in design and manufacture. The proven defective product will either be repaired or replaced, at Weintek's discretion. This warranty shall not cover any product which is

- (a) Out of warranty period which is 12 months from the manufacturing month of the HMI products.
- (b) Damage caused by Force Majeure, accident, negligence, improper installation or misuse.
- (c) Product has been repaired or taken apart by unauthorized technicians.
- (d) Products whose identification markings have been removed or damaged.